

CABINET SET FOAM COMPLETE

Description

Created for high risk situation, such as refineries warehouses and big stores.

It has the same characteristics of mobile unit, in a fixed form.

the complete foam cabinet is mounted in affixed position, on a wall, and allows rapid and quick use.

the system is composed by:

- #1 foam mixer, normally set to operate sucking 3% of foam at 5 bar,
- #1 Ø 45mm high quality hose,
- # 2 25 kg foam tanks,
- # 2 branch pipes, low exp and medium expansion.

Plus a three effects nozzle. (note: 3 effect nozzle can be used only without foam, other wire suction percentage cannot be granted). Endurance of the two foam tanks is around 8 minutes.



Technical features

Height (H) ~ 980 mm
Width(L) ~ 1100 mm
Depth ~ 300 mm
weight ~ 77kg

Autonomy 8' 33"

Water Unlimited

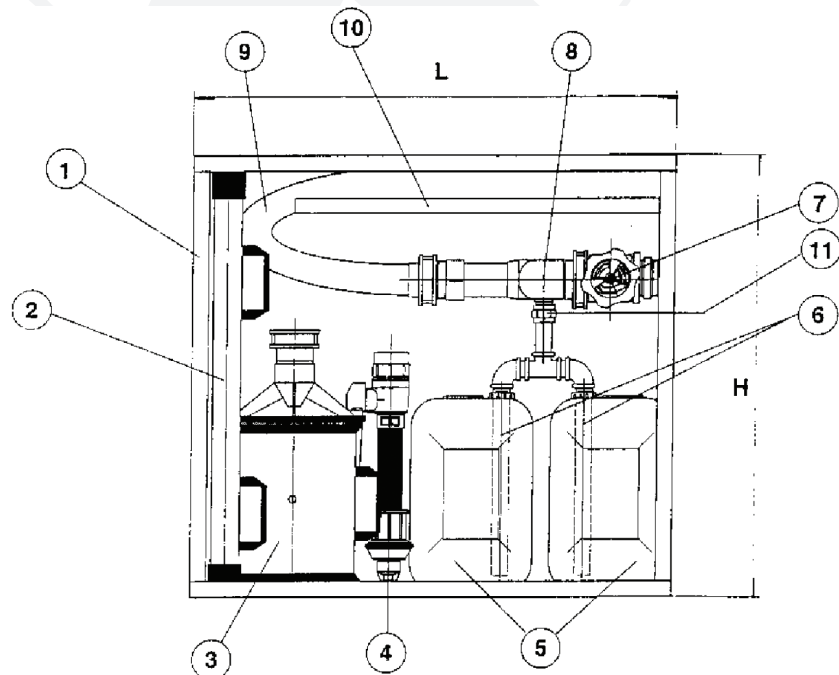

Legend

- | | |
|---|-----------------------|
| 1) Steel cabinet painted red Ral 3000 | 7) Handwheel valve 2" |
| 2) Low expansion foam lance 200 lt/min | 8) Foam mixer |
| 3) Medium expansion foam lance 200 lt/min | 9) Fire hose |
| 4) Nozzle three effects adjustable | 10) Support hose |
| 5) Foam compound synthetic 25kg | 11) Swivel connection |
| 6) Suction tubes complete with filter | |