

NFPA® 750

Standard on  
Water Mist Fire  
Protection Systems

2010 Edition

**DEKA**  
MÜHENDİSLİK

*Yangın Güvenlik Sistemleri  
ve İnş. San. Tic. Ltd. Şti.*



NFPA, 1 Batterymarch Park, Quincy, MA 02169-7471  
An International Codes and Standards Organization

**IMPORTANT NOTICES AND DISCLAIMERS CONCERNING NFPA® DOCUMENTS**  
**NOTICE AND DISCLAIMER OF LIABILITY CONCERNING THE USE OF NFPA DOCUMENTS**

NFPA® codes, standards, recommended practices, and guides (“NFPA Documents”), of which the document contained herein is one, are developed through a consensus standards development process approved by the American National Standards Institute. This process brings together volunteers representing varied viewpoints and interests to achieve consensus on fire and other safety issues. While the NFPA administers the process and establishes rules to promote fairness in the development of consensus, it does not independently test, evaluate, or verify the accuracy of any information or the soundness of any judgments contained in NFPA Documents.

The NFPA disclaims liability for any personal injury, property or other damages of any nature whatsoever, whether special, indirect, consequential or compensatory, directly or indirectly resulting from the publication, use of, or reliance on NFPA Documents. The NFPA also makes no guaranty or warranty as to the accuracy or completeness of any information published herein.

In issuing and making NFPA Documents available, the NFPA is not undertaking to render professional or other services for or on behalf of any person or entity. Nor is the NFPA undertaking to perform any duty owed by any person or entity to someone else. Anyone using this document should rely on his or her own independent judgment or, as appropriate, seek the advice of a competent professional in determining the exercise of reasonable care in any given circumstances.

The NFPA has no power, nor does it undertake, to police or enforce compliance with the contents of NFPA Documents. Nor does the NFPA list, certify, test, or inspect products, designs, or installations for compliance with this document. Any certification or other statement of compliance with the requirements of this document shall not be attributable to the NFPA and is solely the responsibility of the certifier or maker of the statement.

**DEKA**  
**MÜHENDİSLİK**

*Yangın Güvenlik Sistemleri  
ve İnş. San. Tic. Ltd. Şti.*

## IMPORTANT NOTICES AND DISCLAIMERS CONCERNING NFPA DOCUMENTS

### ADDITIONAL NOTICES AND DISCLAIMERS

#### Updating of NFPA Documents

Users of NFPA codes, standards, recommended practices, and guides (“NFPA Documents”) should be aware that these documents may be superseded at any time by the issuance of new editions or may be amended from time to time through the issuance of Tentative Interim Amendments. An official NFPA Document at any point in time consists of the current edition of the document together with any Tentative Interim Amendments and any Errata then in effect. In order to determine whether a given document is the current edition and whether it has been amended through the issuance of Tentative Interim Amendments or corrected through the issuance of Errata, consult appropriate NFPA publications such as the National Fire Codes® Subscription Service, visit the NFPA website at [www.nfpa.org](http://www.nfpa.org), or contact the NFPA at the address listed below.

#### Interpretations of NFPA Documents

A statement, written or oral, that is not processed in accordance with Section 6 of the Regulations Governing Committee Projects shall not be considered the official position of NFPA or any of its Committees and shall not be considered to be, nor be relied upon as, a Formal Interpretation.

#### Patents

The NFPA does not take any position with respect to the validity of any patent rights referenced in, related to, or asserted in connection with an NFPA Document. The users of NFPA Documents bear the sole responsibility for determining the validity of any such patent rights, as well as the risk of infringement of such rights, and the NFPA disclaims liability for the infringement of any patent resulting from the use of or reliance on NFPA Documents.

NFPA adheres to the policy of the American National Standards Institute (ANSI) regarding the inclusion of patents in American National Standards (“the ANSI Patent Policy”), and hereby gives the following notice pursuant to that policy:

**NOTICE:** The user’s attention is called to the possibility that compliance with an NFPA Document may require use of an invention covered by patent rights. NFPA takes no position as to the validity of any such patent rights or as to whether such patent rights constitute or include essential patent claims under the ANSI Patent Policy. If, in connection with the ANSI Patent Policy, a patent holder has filed a statement of willingness to grant licenses under these rights on reasonable and nondiscriminatory terms and conditions to applicants desiring to obtain such a license, copies of such filed statements can be obtained, on request, from NFPA. For further information, contact the NFPA at the address listed below.

#### Law and Regulations

Users of NFPA Documents should consult applicable federal, state, and local laws and regulations. NFPA does not, by the publication of its codes, standards, recommended practices, and guides, intend to urge action that is not in compliance with applicable laws, and these documents may not be construed as doing so.

#### Copyrights

NFPA Documents are copyrighted by the NFPA. They are made available for a wide variety of both public and private uses. These include both use, by reference, in laws and regulations, and use in private self-regulation, standardization, and the promotion of safe practices and methods. By making these documents available for use and adoption by public authorities and private users, the NFPA does not waive any rights in copyright to these documents.

Use of NFPA Documents for regulatory purposes should be accomplished through adoption by reference. The term “adoption by reference” means the citing of title, edition, and publishing information only. Any deletions, additions, and changes desired by the adopting authority should be noted separately in the adopting instrument. In order to assist NFPA in following the uses made of its documents, adopting authorities are requested to notify the NFPA (Attention: Secretary, Standards Council) in writing of such use. For technical assistance and questions concerning adoption of NFPA Documents, contact NFPA at the address below.

#### For Further Information

All questions or other communications relating to NFPA Documents and all requests for information on NFPA procedures governing its codes and standards development process, including information on the procedures for requesting Formal Interpretations, for proposing Tentative Interim Amendments, and for proposing revisions to NFPA documents during regular revision cycles, should be sent to NFPA headquarters, addressed to the attention of the Secretary, Standards Council, NFPA, 1 Batterymarch Park, P.O. Box 9101, Quincy, MA 02169-7471; email: [stds\\_admin@nfpa.org](mailto:stds_admin@nfpa.org)

For more information about NFPA, visit the NFPA website at [www.nfpa.org](http://www.nfpa.org).

Copyright © 2009 National Fire Protection Association®. All Rights Reserved.

**NFPA® 750**

**Standard on**

## **Water Mist Fire Protection Systems**

**2010 Edition**

This edition of NFPA 750, *Standard on Water Mist Fire Protection Systems*, was prepared by the Technical Committee on Water Mist Fire Suppression Systems. It was issued by the Standards Council on October 27, 2009, with an effective date of December 5, 2009, and supersedes all previous editions.

This edition of NFPA 750 was approved as an American National Standard on December 5, 2009.

### **Origin and Development of NFPA 750**

In 1993, representatives from the research and engineering communities, water mist system manufacturers, the insurance industry, enforcement authorities, and industrial users met and organized the NFPA Technical Committee on Water Mist Fire Suppression Systems. The committee started work on developing a new NFPA document that would begin to standardize water mist technology and provide for reliable design and installation of these systems.

Water mist systems were introduced in the 1940s and were utilized for specific applications such as on passenger ferries. The renewed interest in water mist systems is due partially to the phasing out of halon and their potential as a fire safety system for spaces where the amount of water that can be stored or that can be discharged is limited. In addition, their application and effectiveness for residential occupancies, flammable liquids storage facilities, and electrical equipment spaces continues to be investigated with encouraging results.

NFPA 750 contains elements that are similar to standards on other types of fire protection systems such as automatic sprinklers, fixed water spray, carbon dioxide, and halon. In many ways, water mist can be thought of as a hybrid of those systems. Overall, water mist systems utilize water as the extinguishing, suppression, or control medium but do so in a nontraditional manner. In developing this standard, the committee addressed system components and hardware, system types, installation requirements, design objectives, hazard classifications, calculations, water supplies, atomizing media, plans, documentation, acceptance criteria, and maintenance considerations.

The 2000 edition of NFPA 750 represented a significant advancement in water mist technology and the knowledge base associated with its application. That edition included a new definition of *water mist* and a complete rewrite and reorganization of what was Chapter 5, Design Objectives and Fire Test Protocols. Additionally, many new sections were added to address the design and safety considerations associated with positive displacement water mist pumps. New guidance was provided for the measurement of the water mist spray characteristics including drop distribution. Finally, two new appendixes were added to address many of the current and proposed fire test protocols and the reliability of water mist systems.

The 2003 edition incorporated revisions that updated the standard to comply with the *Manual of Style for NFPA Technical Committee Documents*. Style changes included a restructuring of the document, reworded exceptions as requirements, and transition to a metric-as-primary document. The 2003 edition contained updated requirements for additives, proportioning methods, supervision, calculation methods, and inspection and testing of water mist systems. New requirements were added that addressed protection of machinery spaces on towing vessels.

The 2006 edition updated requirements for hangers, supports, reserve water supplies, pump capacities, and appropriate test connections.

The 2010 edition includes new annex material providing guidance on obstruction to nozzle discharge and a number of editorial revisions.

## Technical Committee on Water Mist Fire Suppression Systems

**Larry W. Owen**, *Chair*  
Dooley Tackaberry, Inc., TX [IM]

**John F. Devlin**, Schirmer Engineering Corporation,  
MD [I]  
**Randall Eberly**, U.S. Coast Guard, DC [E]  
**Joshua M. Fleischer**, AREVA Group, CA [U]  
Rep. Edison Electric Institute  
**William A. Froh**, U.S. Department of Energy, DC [U]  
**Raymond N. Hansen**, U.S. Department of the Air Force,  
FL [E]  
**Daniel J. Hubert**, Janus Fire Systems, IN [IM]  
Rep. Fire Suppression Systems Association  
**Mary P. Hunstad**, U.S. Department of the Navy, DC [E]  
**William E. Janz**, XL Global Asset Protection Services,  
IL [I]  
**Robert Kasiski**, FM Global, MA [I]  
**Andrew Kim**, National Research Council of Canada,  
Canada [RT]  
**Max Lakkonen**, FOGTEC Fire Protection, Germany [M]  
Rep. International Water Mist Association  
**George E. Laverick**, Underwriters Laboratories Inc.,  
IL [RT]

**David J. LeBlanc**, Tyco Fire Suppression & Building  
Products, RI [M]  
**Kerry L. Madigan**, Scandaliato Design Group, Inc.,  
CO [IM]  
Rep. American Fire Sprinkler Association  
**Jack R. Mawhinney**, Hughes Associates, Inc., MD [SE]  
**Jason Pope**, National Automatic Sprinkler Fitters LU 669,  
MD [L]  
Rep. United Association of Journeymen & Apprentices  
of the Plumbing & Pipe Fitting Industry  
**Thomas Prymak**, Rolf Jensen & Associates, Inc., TX [SE]  
**William J. Reilly**, Victaulic Company of America, PA [M]  
**Michael B. Stevens**, National Aeronautics & Space  
Administration, FL [U]  
**Brad T. Stilwell**, Fike Corporation, MO [M]  
**Thomas M. Suehr**, Liberty Mutual Property, MA [I]  
Rep. Property Casualty Insurers Association of America  
**Dennis W. Taylor**, WorleyParsons, TX [SE]  
**Victoria B. Valentine**, National Fire Sprinkler Association,  
Inc., NY [M]  
**Thomas F. Ziegler**, Verizon, NJ [U]

### Alternates

**Kerry M. Bell**, Underwriters Laboratories Inc., IL [RT]  
(Alt. to G. E. Laverick)  
**James G. Bisker**, U.S. Department of Energy, DC [U]  
(Alt. to W. A. Froh)  
**Bruce H. Clarke**, XL Global Asset Protection, LLC,  
NC [I]  
(Alt. to W. E. Janz)  
**Robert L. Darwin**, Hughes Associates, Inc., MD [SE]  
(Alt. to J. R. Mawhinney)  
**Eric W. Haberichter**, Kidde/Chemetron Fire Systems,  
IL [IM]  
(Alt. to D. J. Hubert)  
**Rick J. Jackson**, Jackson Associates, Inc., MI [IM]  
(Alt. to K. L. Madigan)

**Michael Koczera**, Liberty Mutual Property, MA [I]  
(Alt. to T. M. Suehr)  
**Robert J. Libby**, The RJA Group, Inc., MD [SE]  
(Alt. to T. Prymak)  
**Earl D. Neargarth**, Fike Corporation, MO [M]  
(Alt. to B. T. Stilwell)  
**Erin A. M. Oneisom**, U.S. Department of the Air Force,  
AE [E]  
(Alt. to R. N. Hansen)  
**Maarit Tuomisaari**, Marioff Corporation Oy, Finland [M]  
(Voting Alt. to Marioff Rep.)  
**Hong-Zeng Yu**, FM Global, MA [I]  
(Alt. to R. Kasiski)

### Nonvoting

**Lawrence A. McKenna, Jr.**, U.S. Department of  
Homeland Security, MD [C]  
**Douglas J. Pickersgill**, Fire and Safety Systems,  
Australia [SE]

**Woodrow W. Stratton**, U.S. Department of Homeland  
Security, MD [C]  
**Fernando Vigara**, APICI, Spain [SE]

**James D. Lake**, NFPA Staff Liaison

*This list represents the membership at the time the Committee was balloted on the final text of this edition. Since that time, changes in the membership may have occurred. A key to classifications is found at the back of the document.*

NOTE: Membership on a committee shall not in and of itself constitute an endorsement of the Association or any document developed by the committee on which the member serves.

**Committee Scope:** This Committee shall have primary responsibility for documents on the design, installation, and maintenance of systems which use a water mist for the control, suppression, or extinguishment of fire.



## Contents

|   |               |  |               |
|---|---------------|--|---------------|
| <b>Chapter 1 Administration</b> .....                 | <b>750- 5</b> | 7.8 Valves and Pressure Gauges .....             | <b>750-19</b> |
| 1.1 Scope .....                                       | <b>750- 5</b> | 7.9 Electrical Systems .....                     | <b>750-20</b> |
| 1.2 Purpose .....                                     | <b>750- 5</b> | 7.10 Test Connections .....                      | <b>750-20</b> |
| 1.3 Application .....                                 | <b>750- 5</b> | <b>Chapter 8 Design Objectives and Fire Test</b> |               |
| 1.4 Retroactivity .....                               | <b>750- 5</b> | <b>Protocols</b> .....                           | <b>750-20</b> |
| 1.5 Equivalency .....                                 | <b>750- 5</b> | 8.1 General .....                                | <b>750-20</b> |
| 1.6 Units .....                                       | <b>750- 5</b> | 8.2 Listing Evaluations .....                    | <b>750-21</b> |
| <b>Chapter 2 Referenced Publications</b> .....        | <b>750- 6</b> | 8.3 Performance Objectives .....                 | <b>750-21</b> |
| 2.1 General .....                                     | <b>750- 6</b> | 8.4 Application Parameters .....                 | <b>750-21</b> |
| 2.2 NFPA Publications .....                           | <b>750- 6</b> | 8.5 Reliability .....                            | <b>750-22</b> |
| 2.3 Other Publications .....                          | <b>750- 6</b> | <b>Chapter 9 Calculations</b> .....              | <b>750-22</b> |
| 2.4 References for Extracts in Mandatory              |               | 9.1 General .....                                | <b>750-22</b> |
| Sections .....  | <b>750- 7</b> | 9.2 Darcy-Weisbach Calculation Method            |               |
| <b>Chapter 3 Definitions</b> .....                    | <b>750- 7</b> | for Intermediate and High Pressure,              |               |
| 3.1 General .....                                     | <b>750- 7</b> | Single Fluid, Single Liquid Phase                |               |
| 3.2 NFPA Official Definitions .....                   | <b>750- 7</b> | Systems .....                                    | <b>750-22</b> |
| 3.3 General Definitions .....                         | <b>750- 7</b> | 9.3 Hazen-Williams Calculation Method            |               |
| <b>Chapter 4 General</b> .....                        | <b>750- 8</b> | (Low Pressure Systems) .....                     | <b>750-22</b> |
| 4.1 General .....                                     | <b>750- 8</b> | 9.4 Calculation Procedures for Propellant        |               |
| 4.2 Safety. ....                                      | <b>750- 8</b> | Gas or Atomizing Media .....                     | <b>750-25</b> |
| <b>Chapter 5 System Components and Hardware</b> ..... | <b>750- 9</b> | <b>Chapter 10 Water Supplies and Atomizing</b>   |               |
| 5.1 General. ....                                     | <b>750- 9</b> | <b>Media</b> .....                               | <b>750-26</b> |
| 5.2 Gas and Water Containers .....                    | <b>750- 9</b> | 10.1 General .....                               | <b>750-26</b> |
| 5.3 Piping and Tube .....                             | <b>750- 9</b> | 10.2 Quantity .....                              | <b>750-26</b> |
| 5.4 Fittings .....                                    | <b>750-10</b> | 10.3 Duration .....                              | <b>750-26</b> |
| 5.5 Hangers/Supports .....                            | <b>750-11</b> | 10.4 Reserve Supplies .....                      | <b>750-26</b> |
| 5.6 Nozzles .....                                     | <b>750-11</b> | 10.5 Water Supplies .....                        | <b>750-26</b> |
| 5.7 Valves .....                                      | <b>750-12</b> | 10.6 Atomizing Media for Twin-Fluid              |               |
| 5.8 Strainers and Filters .....                       | <b>750-12</b> | Systems .....                                    | <b>750-27</b> |
| 5.9 Pump Systems .....                                | <b>750-13</b> | 10.7 Pressure Gauges .....                       | <b>750-28</b> |
| 5.10 Detection, Actuation, Alarm, and                 |               | <b>Chapter 11 Plans and Documentation</b> .....  | <b>750-28</b> |
| Control Systems .....                                 | <b>750-13</b> | 11.1 Working Plans .....                         | <b>750-28</b> |
| 5.11 Compatibility .....                              | <b>750-14</b> | 11.2 Hydraulic Calculation                       |               |
| <b>Chapter 6 System Requirements</b> .....            | <b>750-14</b> | Documentation .....                              | <b>750-29</b> |
| 6.1 General .....                                     | <b>750-14</b> | 11.3 Pneumatic Calculation                       |               |
| 6.2 System Applications .....                         | <b>750-14</b> | Documentation .....                              | <b>750-29</b> |
| 6.3 Nozzle Types .....                                | <b>750-15</b> | 11.4 Detection, Actuation, and Control           |               |
| 6.4 System Requirements. ....                         | <b>750-15</b> | Systems Documentation .....                      | <b>750-29</b> |
| 6.5 Media System Types .....                          | <b>750-15</b> | <b>Chapter 12 System Acceptance</b> .....        | <b>750-30</b> |
| 6.6 Additive Systems .....                            | <b>750-15</b> | 12.1 Approval of Water Mist Systems .....        | <b>750-30</b> |
| <b>Chapter 7 Installation Requirements</b> .....      | <b>750-15</b> | 12.2 Acceptance Requirements .....               | <b>750-30</b> |
| 7.1 General. ....                                     | <b>750-15</b> | <b>Chapter 13 System Maintenance</b> .....       | <b>750-32</b> |
| 7.2 Nozzles .....                                     | <b>750-15</b> | 13.1 Responsibility of the Owner or              |               |
| 7.3 Pipe and Tubing .....                             | <b>750-16</b> | Occupant .....                                   | <b>750-32</b> |
| 7.4 Fittings .....                                    | <b>750-16</b> | 13.2 Inspection and Testing .....                | <b>750-33</b> |
| 7.5 Gas and Water Storage Containers .....            | <b>750-16</b> | 13.3 Maintenance .....                           | <b>750-33</b> |
| 7.6 Pumps and Pump Controllers .....                  | <b>750-18</b> | 13.4 Training .....                              | <b>750-33</b> |
| 7.7 Strainers and Filters .....                       | <b>750-18</b> |  |               |

|  |               |  |               |
|--|---------------|--|---------------|
| <b>Chapter 14 Marine Systems</b> .....                                 | <b>750-33</b> | <b>Annex B Research Summary</b> .....                | <b>750-56</b> |
| 14.1 General .....   | <b>750-33</b> | <b>Annex C Examples of Fire Test Protocols</b> ..... | <b>750-56</b> |
| 14.2 Sprinkler Equivalent Systems .....                                | <b>750-35</b> | <b>Annex D Reliability</b> .....                     | <b>750-63</b> |
| 14.3 Flammable Liquids — Total Area<br>Protection .....                | <b>750-36</b> | <b>Annex E Informational References</b> .....        | <b>750-65</b> |
| 14.4 Human Factors .....   | <b>750-37</b> | <b>Index</b> .....                                   | <b>750-66</b> |
| 14.5 Requirements for Water Mist Systems<br>on Combatant Vessels ..... | <b>750-37</b> |  |               |
| <b>Annex A Explanatory Material</b> .....                              | <b>750-37</b> |  |               |

**DEKA**  
**MÜHENDİSLİK**

*Yangın Güvenlik Sistemleri  
ve İnş. San. Tic. Ltd. Şti.*

**NFPA 750****Standard on****Water Mist Fire Protection Systems****2010 Edition**

**IMPORTANT NOTE:** This NFPA document is made available for use subject to important notices and legal disclaimers. These notices and disclaimers appear in all publications containing this document and may be found under the heading "Important Notices and Disclaimers Concerning NFPA Documents." They can also be obtained on request from NFPA or viewed at [www.nfpa.org/disclaimers](http://www.nfpa.org/disclaimers).

**NOTICE:** An asterisk (\*) following the number or letter designating a paragraph indicates that explanatory material on the paragraph can be found in Annex A.

Changes other than editorial are indicated by a vertical rule beside the paragraph, table, or figure in which the change occurred. These rules are included as an aid to the user in identifying changes from the previous edition. Where one or more complete paragraphs have been deleted, the deletion is indicated by a bullet (•) between the paragraphs that remain.

A reference in brackets [ ] following a section or paragraph indicates material that has been extracted from another NFPA document. As an aid to the user, the complete title and edition of the source documents for extracts in mandatory sections of the document are given in Chapter 2 and those for extracts in informational sections are given in Annex E. Extracted text may be edited for consistency and style and may include the revision of internal paragraph references and other references as appropriate. Requests for interpretations or revisions of extracted text shall be sent to the technical committee responsible for the source document.

Information on referenced publications can be found in Chapter 2 and Annex E.

**Chapter 1 Administration**

**1.1\* Scope.** This standard contains the minimum requirements for the design, installation, maintenance, and testing of water mist fire protection systems. This standard does not provide definitive fire performance criteria, nor does it offer specific guidance on how to design a system to control, suppress, or extinguish a fire. Reliance is placed on the procurement and installation of listed water mist equipment or systems that have demonstrated performance in fire tests as part of a listing process.

**1.2\* Purpose.**

**1.2.1** The purpose of this standard is to provide protection for life and property from fire through the standardization of design, installation, maintenance, and testing requirements for water-based fire suppression systems that use a specific spray (mist) that absorbs heat, displaces oxygen, or blocks radiant heat to control, suppress, or extinguish fires as required by the application.

**1.2.2** The user of this standard shall recognize the complexity of water mist fire suppression systems. Therefore, the designer shall be cautioned that the standard is not a design handbook. The standard shall not do away with the need for the engineer or for competent engineering judgment. It is the intent that a designer capable of applying more complete and rigorous analysis to special or unusual problems shall have latitude in the development of such designs. In such cases, the designer shall be responsible for demonstrating the validity of the design approach.

**1.3 Application.** This standard shall apply to water mist fire protection systems and shall establish minimum requirements for water mist technology on the basis of sound engineering principles, test data, and field experience.

**1.4 Retroactivity.** The provisions of this standard reflect a consensus of what is necessary to provide an acceptable degree of protection from the hazards addressed in this standard at the time the standard was issued.

**1.4.1** Unless otherwise specified, the provisions of this standard shall not apply to facilities, equipment, structures, or installations that existed or were approved for construction or installation prior to the effective date of the standard. Where specified, the provisions of this standard shall be retroactive.

**1.4.2** In those cases where the authority having jurisdiction determines that the existing situation presents an unacceptable degree of risk, the authority having jurisdiction shall be permitted to apply retroactively any portions of this standard deemed appropriate.

**1.4.3** The retroactive requirements of this standard shall be permitted to be modified if their application clearly would be impractical in the judgment of the authority having jurisdiction, and only where it is clearly evident that a reasonable degree of safety is provided.

**1.5 Equivalency.** Nothing in this standard is intended to prevent the use of systems, methods, or devices of equivalent or superior quality, strength, fire resistance, effectiveness, durability, and safety over those prescribed by this standard.

**1.5.1** Technical documentation shall be submitted to the authority having jurisdiction to demonstrate equivalency.

**1.5.2** The system, method, or device shall be approved for the intended purpose by the authority having jurisdiction.

**1.6\* Units.**

**1.6.1** Metric units of measurement in this standard are in accordance with the modernized metric system known as the International System of Units (SI).

**1.6.2** Two units (liter and bar) outside of but recognized by SI are commonly used in international fire protection.

**1.6.3** These units are listed in Table 1.6.3 with conversion factors.

**1.6.4** If a value for measurement as given in this standard is followed by an equivalent value in other units, the first stated is to be regarded as the requirement.



**Table 1.6.3 Metric Conversion Factors**

| Name of Unit                      | Unit Abbreviation or Symbol | Conversion Factor                                 |
|-----------------------------------|-----------------------------|---|
| Millimeter                        | mm                          | 1 in. = 25.4 mm                                   |
| Square meter                      | m <sup>2</sup>              | 1 ft <sup>2</sup> = 0.0929 m <sup>2</sup>         |
| Liter                             | L                           | 1 gal = 3.785 L                                   |
| Cubic decimeter                   | dm <sup>3</sup>             | 1 gal = 3.785 dm <sup>3</sup>                     |
| Cubic meter                       | m <sup>3</sup>              | 1 ft <sup>3</sup> = 0.028317 m <sup>3</sup>       |
| Kilogram                          | kg                          | 1 lb = 0.4536 kg                                  |
| Kilograms per cubic meter         | kg/m <sup>3</sup>           | 1 lb/ft <sup>3</sup> = 16.0183 kg/m <sup>3</sup>  |
| Pascal                            | Pa                          | 1 psi = 6895 Pa                                   |
| Bar                               | bar                         | 1 psi = 0.0689 bar;<br>1 bar = 10 <sup>5</sup> Pa |
| Liter per minute per square meter | L/min/m <sup>2</sup>        | 1 gpm = 40.746 L/min/m <sup>2</sup>               |
| Micron                            | μ                           | 1 mm = 1000 μ                                     |

## Chapter 2 Referenced Publications

**2.1 General.** The documents or portions thereof listed in this chapter are referenced within this standard and shall be considered part of the requirements of this document.

**2.2 NFPA Publications.** National Fire Protection Association, 1 Batterymarch Park, Quincy, MA 02169-7471.

NFPA 13, *Standard for the Installation of Sprinkler Systems*, 2010 edition.

NFPA 20, *Standard for the Installation of Stationary Pumps for Fire Protection*, 2010 edition.

NFPA 22, *Standard for Water Tanks for Private Fire Protection*, 2008 edition.

NFPA 25, *Standard for the Inspection, Testing, and Maintenance of Water-Based Fire Protection Systems*, 2008 edition.

NFPA 70<sup>®</sup>, *National Electrical Code*<sup>®</sup>, 2008 edition.

NFPA 72<sup>®</sup>, *National Fire Alarm and Signaling Code*, 2010 edition.

NFPA 170, *Standard for Fire Safety and Emergency Symbols*, 2009 edition.

### 2.3 Other Publications.

**2.3.1 ANSI Publications.** American National Standards Institute, Inc., 25 West 43rd Street, 4th Floor, New York, NY 10036.

ANSI B1.20.1, *Pipe Threads, General Purpose (Inch)*, 1992.

ANSI B16.18, *Cast Copper Alloy Solder Joint Pressure Fittings*, 1994.

ANSI B16.22, *Wrought Copper and Copper Alloy Solder Joint Pressure Fittings*, 1995.

**2.3.2 ASME Publications.** American Society of Mechanical Engineers, Three Park Avenue, New York, NY 10016-5990.

ASME *Boiler and Pressure Vessel Code*, 2001.

ASME B31.1, *Power Piping Code*, 1998.

**2.3.3 ASTM Publications.** ASTM International, 100 Barr Harbor Drive, P. O. Box C700, West Conshohocken, PA 19428-2959.

ASTM A 269, *Standard Specification for Seamless and Welded Austenitic Stainless Steel Tubing for General Service*, 2000.

ASTM A 351/ASTM A 351M, *Standard Specification for Castings, Austenitic, Austenitic-Ferritic (Duplex) for Pressure-Containing Parts*, 2000.

ASTM A 403/ASTM A 403M, *Standard Specification for Wrought Austenitic Stainless Steel Piping Fittings*, 2000.

ASTM A 632, *Standard Specification for Seamless and Welded Austenitic Stainless Steel Tubing (Small-Diameter) for General Service*, 1990.

ASTM A 774/ASTM A 774M, *Standard Specification for As-Welded Wrought Austenitic Stainless Steel Fittings for General Corrosive Service at Low and Moderate Temperatures*, 2000.

ASTM A 778, *Standard Specification for Welded, Unannealed Austenitic Stainless Steel Tubular Products*, 2000.

ASTM A 789/ASTM A 789M, *Standard Specification for Seamless and Welded Ferritic/Austenitic Stainless Steel Tubing for General Service*, 1995.

ASTM A 815/ASTM A 815M, *Standard Specification for Wrought Ferritic, Ferritic/Austenitic, and Martensitic Stainless Steel Piping Fittings*, 1998.

ASTM B 32, *Standard Specification for Solder Metal*, 2000.

ASTM B 42, *Standard Specification for Seamless Copper Pipe, Standard Sizes*, 1998.

ASTM B 75, *Standard Specification for Seamless Copper Tube*, 1999.

ASTM B 88, *Standard Specification for Seamless Copper Water Tube*, 1999.

ASTM B 251, *Standard Specification for General Requirements for Wrought Seamless Copper and Copper-Alloy Tube*, 1997.

ASTM B 813, *Standard Specification for Liquid and Paste Fluxes for Soldering Applications of Copper and Copper-Alloy Tube*, 2000.

**2.3.4 AWS Publications.** American Welding Society, 550 N.W. LeJeune Road, Miami, FL 33126.

AWS A5.8, *Specification for Filler Metals for Brazing and Braze Welding*, 1992.

AWS D10.9, *Specification for Qualification of Welding Procedures and Welders for Piping and Tubing*, 1980.

**2.3.5 IMO Publications.** International Maritime Organization, 4 Albert Embankment, London, SE1 7SR, United Kingdom.

IMO Assembly Resolution A.800(19), *Revised Guidelines for Approval of Sprinkler Systems*.

IMO Code for Application of Fire Test Procedures, 1998.

IMO MSC/Circ. 668, *Alternative Arrangements for Halon Fire-Extinguishing Systems in Machinery Spaces and Pumprooms*.

IMO MSC/Circ. 728, *Revised Test Method for Equivalent Water-Based Fire-Extinguishing Systems for Machinery Spaces of Category A and Cargo Pump-Rooms Contained in MSC/Circ. 668*.

IMO MSC/Circ. 913, *Guidelines for the Approval of Fixed Water-Based Local Application Fire-Fighting Systems for Use in Category A Machinery Spaces*, 1999.

SOLAS Regulation 11-2/12.4.1, Consolidated Edition, 1992.

**2.3.6 ISO Publications.** International Organization for Standardization, 1 rue de Varembe, Case postale 56, CH-1211 Geneva 20, Switzerland.

ISO 1219-1, *Fluid power systems and components — Graphic symbols and circuit diagrams — Part 1: Graphic symbols*, 1991.

ISO 1219-2, *Fluid power systems and components — Graphic symbols and circuit diagrams — Part 2: Circuit diagrams*, 1995.



**2.3.7 ULC Publications.** Underwriters' Laboratories of Canada, 7 Underwriters Road, Toronto, Ontario M1R 3B4, Canada.

CAN/ULC S524-06, *Standard for the Installation of Fire Alarm Systems*, 2006.

CAN/ULC S529-02, *Standard for Smoke Detectors for Fire Alarm Systems*, 2002.

**2.3.8 U.S. Coast Guard Publication.** 2100 Second Street, S.W., Washington, DC 20593-0001.

NVIC 9-97, *Guide to Structural Fire Protection*, 1997.

**2.3.9 U.S. Government Publication.** U.S. Government Printing Office, Washington, DC 20402.

Title 46, Code of Federal Regulations, Parts 56.50 and 56.75, "Shipping."

Title 49, Code of Federal Regulations, "Transportation."

**2.3.10 Other Publications.** *Merriam-Webster's Collegiate Dictionary*, 11th edition, Merriam-Webster, Inc., Springfield, MA, 2003.

## 2.4 References for Extracts in Mandatory Sections.

NFPA 25, *Standard for the Inspection, Testing, and Maintenance of Water-Based Fire Protection Systems*, 2008 edition.

## Chapter 3 Definitions

**3.1 General.** The definitions contained in this chapter shall apply to the terms used in this standard. Where terms are not defined in this chapter or within another chapter, they shall be defined using their ordinarily accepted meanings within the context in which they are used. *Merriam-Webster's Collegiate Dictionary*, 11th edition, shall be the source for the ordinarily accepted meaning.

### 3.2 NFPA Official Definitions.

**3.2.1\* Approved.** Acceptable to the authority having jurisdiction.

**3.2.2\* Authority Having Jurisdiction (AHJ).** An organization, office, or individual responsible for enforcing the requirements of a code or standard, or for approving equipment, materials, an installation, or a procedure.

**3.2.3\* Listed.** Equipment, materials, or services included in a list published by an organization that is acceptable to the authority having jurisdiction and concerned with evaluation of products or services, that maintains periodic inspection of production of listed equipment or materials or periodic evaluation of services, and whose listing states that either the equipment, material, or service meets appropriate designated standards or has been tested and found suitable for a specified purpose.

**3.2.4 Shall.** Indicates a mandatory requirement.

**3.2.5 Should.** Indicates a recommendation or that which is advised but not required.

**3.2.6 Standard.** A document, the main text of which contains only mandatory provisions using the word "shall" to indicate requirements and which is in a form generally suitable for mandatory reference by another standard or code or for adoption into law. Nonmandatory provisions shall be located in an

appendix or annex, footnote, or fine-print note and are not to be considered a part of the requirements of a standard.

### 3.3 General Definitions.

**3.3.1\* Additive.** Any chemical or mixture of chemicals intentionally introduced into the system.

**3.3.2\* Additive Proportioning.** Additive proportioning is the method (such as premix, metered, or balanced pressure) used for the introduction of an additive or additive mixture at the recommended percent ratio into the water system.

**3.3.3 Deluge System.** A water mist system using open nozzles attached to a piping system that is connected to a water supply through a valve that is opened by means of a detection system installed in the same area as the mist nozzles. When the valve opens, water flows into the piping system and discharges through all nozzles attached to the system.

**3.3.4\*  $D_v$ .** A drop diameter such that the cumulative volume, from zero diameter to this respective diameter, is the fraction,  $f$ , of the corresponding sum of the total distribution.

**3.3.5\* Enclosure.** A confined or partially confined volume.

**3.3.6 Escutcheon.** A protective or ornamental plate or flange.

**3.3.7 Fire Control.** Limiting the size of a fire by distribution of water so as to decrease the heat release rate and pre-wet adjacent combustibles, while controlling ceiling gas temperatures to avoid structural damage.

**3.3.8 Fire Extinguishment.** The complete suppression of a fire until there are no burning combustibles.

**3.3.9 Fire Suppression.** The sharp reduction of the rate of heat release of a fire and the prevention of regrowth.

**3.3.10 High Pressure System.** A water mist system where the distribution system piping is exposed to pressures of 34.5 bar (500 psi) or greater.

**3.3.11 Intermediate Pressure System.** A water mist system where the distribution system piping is exposed to pressures greater than 12.1 bar (175 psi) but less than 34.5 bar (500 psi).

**3.3.12 Low Pressure System.** A water mist system where the distribution piping is exposed to pressures of 12.1 bar (175 psi) or less.

**3.3.13 Propellant.** Compressed gas used as a prime mover to push water out of storage vessels, through pipe networks, or through distribution components.

**3.3.14\* Shall be Considered.** Requires an objective assessment, the results and basis of which are documented, to determine to what extent the specific factor, criterion, guideline, standard, and so forth, is incorporated into or satisfied by the design.

**3.3.15 Single-Fluid System.** A water mist system utilizing a single piping system to supply each nozzle.

**3.3.16 Supervision.** In water-based fire protection systems, a means of monitoring system status and indicating abnormal conditions. [25, 2008]

**3.3.17 Total Compartment Application System.** A system designed to discharge water mist to protect all hazards in an enclosure.

**3.3.18 Twin-Fluid System.** A water mist system in which water and atomizing media are separately supplied to and mixed at the water mist nozzle.

**3.3.19\* Water Mist.** A water spray for which the  $Dv_{0.99}$ , for the flow-weighted cumulative volumetric distribution of water droplets, is less than 1000 microns at the minimum design operating pressure of the water mist nozzle.

**3.3.20 Water Mist, Atomizing Media.** Compressed air or other gases that produce water mist by mechanical mixing with water.

**3.3.21 Water Mist Nozzle.** A special purpose device, containing one or more orifices, designed to produce and deliver a water spray meeting either the definition of *water mist* or meeting the specific requirements of an approved water mist fire test protocol. (See Annex C.)

**3.3.21.1 Automatic Water Mist Nozzles.** Nozzles that operate independently of other nozzles by means of a detection/activation device built into the nozzle.

**3.3.21.2\* Hybrid Water Mist Nozzles.** Nozzles capable of operation using both automatic and nonautomatic means.

**3.3.21.3 Nonautomatic Water Mist Nozzles (Open).** Nozzles that operate as an entire system or grouping of nozzles, containing open orifices and activating the water flow to the nozzles by an independent detection system.

**3.3.22 Water Mist System.** A distribution system connected to a water supply or water and atomizing media supplies that is equipped with one or more nozzles capable of delivering water mist intended to control, suppress, or extinguish fires and that has been demonstrated to meet the performance requirements of its listing and this standard.

**3.3.22.1 Dry Pipe Water Mist System.** A water mist system using automatic nozzles attached to a piping system containing air, nitrogen, or inert gas under pressure, the release of which (as from an opening of an automatic nozzle) allows the water pressure to open a dry pipe valve. The water then flows into the piping system and out through any open nozzles.

**3.3.22.2 Engineered Water Mist Systems.** Those systems that need individual calculation and design to determine the flow rates, nozzle pressures, pipe size, area, or volume protected by each nozzle, discharge density of water mist, the number and types of nozzles, and the nozzle placement in a specific system.

**3.3.22.3 Local-Application Water Mist System.** A water mist system arranged to discharge directly on an object or hazard in an enclosed, unenclosed, or open outdoor condition.

**3.3.22.4 Preaction Water Mist System.** A water mist system using automatic nozzles attached to a piping system that contains air that might or might not be under pressure, with a supplemental detection system installed in the same areas as the mist nozzles. The actuation of the detection system opens a valve that allows water to flow into the piping system and discharges through all opened nozzles in the system.

**3.3.22.5\* Pre-engineered Water Mist Systems.** Those systems having predetermined flow rates, nozzle pressures, and water quantities.

**3.3.22.6 Wet Pipe Water Mist System.** A water mist system using automatic nozzles attached to a piping system containing water and connected to a water supply so that water discharges immediately from nozzles operated by the heat from a fire.

**3.3.23 Working Pressure.** The maximum anticipated static (nonflowing) pressure applied to the system components exclusive of surge pressures.

**3.3.24 Zoned Application System.** A system designed to protect hazards in a predetermined portion of an enclosure.

## Chapter 4 General

### 4.1\* General.

#### 4.1.1 Use and Limitations.

**4.1.1.1** Water mist systems shall be permitted for use with a wide range of performance objectives, including the following:

- (1) Fire extinguishment
- (2) Fire suppression
- (3) Fire control
- (4) Temperature control
- (5) Exposure protection

**4.1.1.2\*** Water mist systems shall not be used for direct application to materials that react with water to produce violent reactions or significant amounts of hazardous products. Such materials include the following:

- (1) Reactive metals, such as lithium, sodium, potassium, magnesium, titanium, zirconium, uranium, and plutonium
- (2) Metal alkoxides, such as sodium methoxide
- (3) Metal amides, such as sodium amide
- (4) Carbides, such as calcium carbide
- (5) Halides, such as benzoyl chloride and aluminum chloride
- (6) Hydrides, such as lithium aluminum hydride
- (7) Oxyhalides, such as phosphorus oxybromide
- (8) Silanes, such as trichloromethylsilane
- (9) Sulfides, such as phosphorus pentasulfide
- (10) Cyanates, such as methylisocyanate

**4.1.1.3** Water mist systems shall not be used for direct application to liquefied gases at cryogenic temperatures (such as liquefied natural gas), which boil violently when heated by water.

### 4.2\* Safety.

#### 4.2.1\* Electrical Clearances.

**4.2.1.1\*** All system components shall be located to maintain minimum clearances from unenclosed and uninsulated energized electrical components in accordance with *NFPA 70, National Electrical Code*.

**4.2.1.2** Where the design basic insulation level (BIL) is not known and where nominal voltage is used for the design criteria, the highest minimum clearance specified for this group shall be used.

**4.2.1.3** The selected clearance to ground shall satisfy the greater of the switching surges or BIL duty, rather than being based on nominal voltage.

**4.2.1.4** The clearance between uninsulated energized parts of the electrical system equipment and any portion of the water mist system shall not be less than the minimum clearance provided elsewhere for electrical system insulation on any individual component.

#### 4.2.2 Environmental Factors.

**4.2.2.1** When selecting water mist to protect a hazard area, the effects of water runoff on the environment shall be considered.



## Chapter 5 System Components and Hardware

**5.1 General.** This chapter provides the requirements for water mist system components.

### 5.1.1 Component Listing.

**5.1.1.1** Unless the requirements of 5.1.1.2 or 5.1.1.3 are met, all water mist system components shall be listed for their intended use.

**5.1.1.2** The requirements of 5.1.1.1 shall not apply where approved components are specifically permitted to be substituted for listed components.

**5.1.1.3** The requirements of 5.1.1.1 shall not apply to individual components where the components are part of a listed, pre-engineered system.

### 5.1.2 Working Pressure.

**5.1.2.1** System components shall be rated for the maximum working pressure to which they are exposed but not less than 12.1 bar (175 psi).

**5.1.2.2** Where components are part of a listed, pre-engineered system with a self-contained water supply, the pressure rating shall be in accordance with the listing requirements.

### 5.1.3 Corrosion Resistance.

**5.1.3.1 Corrosive Atmospheres.** Where components are subjected to severe corrosive atmospheres, corrosion protection such as special corrosion-resistive materials or coating shall be required.

**5.1.3.2\* Water Additives.** All components in the water mist systems and the additive injection system shall be of corrosion-resistant material.

## 5.2 Gas and Water Containers.

**5.2.1 Capacity.** Gas and water containers, where provided, shall be sized to supply quantities of gas and water as required by Chapter 10.

### 5.2.2 Design.

**5.2.2.1\* Installation.** Gas and water containers shall be designed for installation according to the manufacturer's installation manual, including provision for attachment of seismic restraint.

**5.2.2.2\* Specifications.** Gas and water containers subject to pressurization shall be made, tested, approved, equipped, and marked in accordance with the current specifications of the ASME *Boiler and Pressure Vessel Code*, Section VIII, or the requirements of the U.S. Department of Transportation, 49 CFR 171-190, 178.36-178.37, or other approved international standards.

**5.2.2.3 Shipping Containers.** Containers used as shipping containers shall be designed to meet the requirements of the U.S. Department of Transportation or of Transport Canada or of other approved international standards.

**5.2.2.4 Design Pressure.** The design pressure shall be based on the maximum pressure developed by the water mist system at 54°C (130°F).

**5.2.2.5 Excess Pressure.** Each pressurized container shall be provided with a safety device to release excess pressure.

### 5.2.2.6 Water Container Nameplate.

**5.2.2.6.1** Unless the requirements of 5.2.2.6.2 are met, each water container shall have a permanent nameplate or other permanent marking specifying the liquid held in the container (including additives) and the nominal water volume and pressurization level (where applicable) of the container.

**5.2.2.6.2** The requirements of 5.2.2.6.1 shall not apply where the information required by 5.2.2.8.1 is provided on a nameplate or placard permanently installed on the system at a location convenient for servicing or content measuring.

**5.2.2.7 Sight Glasses.** External sight glasses on water containers shall be protected against mechanical damage.

### 5.2.2.8 Gas Container Nameplate.

**5.2.2.8.1** Unless the requirements of 5.2.2.8.2 are met, each gas container shall have a permanent nameplate or other permanent marking specifying the type of gas, weight of gas, weight of container, nominal gas volume, and pressurization level of the container.

**5.2.2.8.2** The requirements of 5.2.2.8.1 shall not apply where the information required by 5.2.2.8.1 is provided on a nameplate or placard permanently installed on the system at a location convenient for servicing or content measuring.

**5.2.2.9 Pressure Indicator.** A reliable means shall be provided to indicate the pressure in refillable, pressurized gas containers.

**5.2.3 Multiple Container Systems.** All containers supplying the same manifold outlet shall be interchangeable and of the same size and charge.

## 5.3 Piping and Tube.

### 5.3.1\* General.

**5.3.1.1** All piping, valves, and fittings, from the system strainer to the nozzle, shall have corrosion resistance at least equivalent to piping specified in Table 5.3.3.1.

**5.3.1.2** Wherever the word *pipe* is used, it shall be understood also to mean *tube*.

### 5.3.2\* Other Types of Pipe or Tube.

**5.3.2.1** Other types of pipe or tube investigated for suitability in water mist system installations and listed for this service shall be permitted where installed in accordance with their listing limitations, including installation instructions.

**5.3.2.2** Bending of the pipe shall be permitted as provided by the listing.

**5.3.2.3** Pipe or tube shall not be listed for portions of an occupancy classification.

### 5.3.3 Low Pressure Systems.

**5.3.3.1** Pipe or tube used in low pressure water mist systems shall meet or exceed one of the standards in Table 5.3.3.1 or shall be in accordance with 5.3.2.

**5.3.3.2** The chemical properties, physical properties, and dimensions of the materials given in Table 5.3.3.1 shall conform at a minimum to the standards cited in the table.

**5.3.3.3** Pipe and tube used in low pressure water mist systems shall be designed to withstand a working pressure of not less than 12.1 bar (175 psi).

**Table 5.3.3.1 Pipe or Tube Standards**

| Materials and Dimensions and Standard Titles   | Standard No.          |
|--|-----------------------|
| <b>Copper Tube (Drawn, Seamless)</b>   |                       |
| <i>Standard Specification for Solder Metal [95-5 (Tin-Antimony-Grade 95TA)]</i>  | ASTM B 32             |
| <i>Standard Specification for Seamless Copper Tube*</i>  | ASTM B 75             |
| <i>Standard Specification for Seamless Copper Water Tube*</i>  | ASTM B 88             |
| <i>Standard Specification for General Requirements for Wrought Seamless Copper and Copper-Alloy Tube</i>                     | ASTM B 251            |
| <i>Standard Specification for Liquid and Paste Fluxes for Soldering Applications of Copper and Copper-Alloy Tube</i>         | ASTM B 813            |
| <i>Specification for Filler Metals for Brazing and Braze Welding (Classification BCuP-3 or BCuP-4)</i>                       | AWS A5.8              |
| <b>Stainless Steel</b>   |                       |
| <i>Standard Specification for Seamless and Welded Austenitic Stainless Steel Tubing for General Service</i>                  | ASTM A 269            |
| <i>Standard Specification for Seamless and Welded Austenitic Stainless Steel Tubing (Small-Diameter) for General Service</i> | ASTM A 632            |
| <i>Standard Specification for Welded, Unannealed Austenitic Stainless Steel Tubular Products</i>                             | ASTM A 778            |
| <i>Standard Specification for Seamless and Welded Ferritic/Austenitic Stainless Steel Tubing for General Service</i>         | ASTM A 789/<br>A 789M |

\*Denotes pipe or tube suitable for bending (see 5.3.6) according to ASTM standards.

**5.3.3.4** Copper tube as specified in the standards referenced in Table 5.3.3.1 shall have a wall thickness of Type K, L, or M where used in water mist systems.

#### 5.3.4 Intermediate and High Pressure Systems.

**5.3.4.1\*** Pipe or tube shall be of noncombustible material having physical and chemical characteristics such that its deterioration under stress can be predicted with reliability.

**5.3.4.2** The piping shall be in accordance with ASME B31.1, *Power Piping Code*.

**5.3.4.3** Where using the equations provided in ASME B31.1 to calculate either the maximum working pressure ( $P_w$ ) for a specific pipe or tube or the minimum wall thickness ( $t_m$ ) of the pipe or tube for a specific operating pressure, a steel temperature of 54°C (130°F) or the expected ambient temperature to which the pipe or tube will be exposed shall be used, whichever is greater.

**5.3.4.4\*** Flexible piping, tubing, or hoses (including connections) shall be listed for their intended use.

#### 5.3.5 Pipe or Tube Identification.

**5.3.5.1** All pipe or tube, including specially listed pipe or tube, shall be marked continuously along its length by the manufacturer in such a way as to identify the type of pipe or tube.

**5.3.5.2** Pipe or tube identification shall include the manufacturer's name, model designation, or schedule.

**5.3.5.3** Pipe or tube marking shall not be painted, concealed, or removed prior to approval by the authority having jurisdiction.

#### 5.3.6\* Pipe or Tube Bending.

**5.3.6.1** Bending of Type K and Type L copper tube or stainless steel tube or pipe shall be permitted, provided that all bending details are in accordance with the tubing manufacturer's recommendations, the strength requirements of ASME B31.1, *Power Piping Code*, or the following, whichever is greatest:

- (1) For Type K or Type L copper tubing and stainless steel pipe, the minimum bending radius is six pipe or tube diameters.
- (2) For Type 304L or Type 316 stainless steel tube, the minimum bending radius is two diameters up to 38 mm (1½ in.) OD, and four diameters for 51 mm (2 in.) tubing.

**5.3.6.2** Bending tools shall be used for all bending in accordance with the following:

- (1) Power bending tools with the correct radius dies shall be required for pipe and tube larger than 20 mm (¾ in.).
- (2) Hand or bench dies with the correct radius dies shall be permitted to be used to bend pipe or tubing 20 mm (¾ in.) and smaller.
- (3) Flattened bends where the larger diameter is greater than 1.08 times the least diameter shall not be permitted.

#### 5.4 Fittings.

##### 5.4.1\* General.

**5.4.1.1 Fittings.** All fittings used on piping described in 5.3.1 shall have a corrosion resistance at least equivalent to wrought copper fittings conforming to ANSI B16.22, *Wrought Copper and Copper Alloy Solder Joint Pressure Fittings*.

##### 5.4.1.2 Conversion Fittings.

**5.4.1.2.1** Conversion fittings from metric to fractional units shall be identified by color or tagging for quick notification in the field.

**5.4.1.2.2** A supply of spare adapters shall be maintained on the premises so that any adapters that have been damaged in any way can be promptly replaced.

**5.4.1.2.3** Adapter information shall also be maintained on the drawings.

##### 5.4.2 Low Pressure Systems.

**5.4.2.1** Fittings used in water mist systems shall meet or exceed the standards in Table 5.4.2.1 or shall be in accordance with 5.4.2.2.

**5.4.2.2\*** Other types of fittings investigated for suitability in water mist installations and listed for this service shall be permitted where installed in accordance with their listing limitations, including installation instructions.

**5.4.2.3** Screwed unions shall not be used on pipe larger than 51 mm (2 in.).

**5.4.2.4** Couplings and unions of other than the screwed type shall be listed for the intended use.

**5.4.2.5** A one-piece reducing fitting shall be used wherever a change is made in the size of pipe.



**Table 5.4.2.1 Fitting Standards**

| Materials and Dimensions and Standard Titles   | Standard No.      |
|--|-------------------|
| <b>Copper</b>  |                   |
| <i>Cast Copper Alloy Solder Joint Pressure Fittings</i>  | ANSI B16.18       |
| <i>Wrought Copper and Copper Alloy Solder Joint Pressure Fittings</i>  | ANSI B16.22       |
| <b>Stainless Steel</b>   |                   |
| <i>Standard Specification for Castings, Austenitic, Austenitic-Ferritic (Duplex) for Pressure-Containing Parts</i>                                     | ASTM A 351/A 351M |
| <i>Standard Specification for Wrought Austenitic Stainless Steel Piping Fittings</i>   | ASTM A 403/A 403M |
| <i>Standard Specification for As-Welded Wrought Austenitic Stainless Steel Fittings for General Corrosive Service at Low and Moderate Temperatures</i> | ASTM A 774/A 774M |
| <i>Standard Specification for Wrought Ferritic, Ferritic/Austenitic, and Martensitic Stainless Steel Piping Fittings</i>                               | ASTM A 815/A 815M |

**5.4.2.6** Where standard fittings of the required size are not produced, hexagonal or face bushings shall be permitted in reducing the size of openings of fittings and shall meet the requirements of 5.4.2.5.

**5.4.2.7** All threads used in joints and fittings shall conform to ANSI B1.20.1, *Pipe Threads, General Purpose (Inch)*. Joint compound, tape, or thread lubricant shall be applied only to the male threads of the joint.

**5.4.2.8** Soldering fluxes shall be in accordance with Table 5.3.3.1.

**5.4.2.9** Brazing fluxes, if used, shall not be of a highly corrosive type.

**5.4.2.10** Welding shall be performed in accordance with AWS D10.9, *Specification for Qualification of Welding Procedures and Welders for Piping and Tubing*, Level AR-3.

#### 5.4.3 Intermediate and High Pressure Systems.

**5.4.3.1** Fittings shall have a minimum-rated working pressure equal to or greater than the maximum operating pressure of the water mist systems at 54°C (130°F).

**5.4.3.2** For systems that employ the use of a pressure regulating device in the distribution piping, the fittings downstream of the device shall have a minimum-rated working pressure equal to or greater than the maximum anticipated pressure in the downstream piping.

**5.4.3.3** All threads used in joints and fittings shall conform to ANSI B1.20.1, *Pipe Threads, General Purpose (Inch)*.

**5.4.3.4** Joint compound, tape, or thread lubricant shall be applied only to the male threads of the joint.

**5.4.3.5** Welding and brazing alloys shall have a melting point above 538°C (1000°F).

**5.4.3.6** Welding and brazing shall be performed in accordance with Section IX of the ASME *Boiler and Pressure Vessel Code*.

**5.4.3.7** Where acceptable tubing is joined with compression-type fittings, the manufacturer's pressure temperature ratings for the fitting shall not be exceeded.

#### 5.5 Hangers/Supports.

**5.5.1 Supports.** All references to hangers shall include supports.

**5.5.2 Listing.** Unless the requirements of 5.5.3 are met, hangers shall be listed for use with the pipe or tube involved.

#### 5.5.3 Special Designed Hangers.

**5.5.3.1** The requirements of 5.5.2 shall not apply to hangers where the following conditions are met:

- (1) Documentation shall be submitted to show that the hangers and hanging method are recognized as good industry practice for the piping system.
- (2) Hangers shall be designed to support five times the weight of the pipe or tube when filled with gas or water, based on the system's use of the pipe or tube, plus 114 kg (250 lb) at each point of piping support.
- (3) The points of support shall be able to support the water mist system.
- (4) Hanger components shall be metal.
- (5) Plastic inserts shall be permitted in tube clamps to avoid dissimilar metal reactions or dampen vibrations.

**5.5.3.2** Detailed calculations shall be submitted, where required by the authority having jurisdiction, showing the stresses developed in both the hangers and the piping and the safety factors provided.

**5.5.4 Bending.** Threaded portions of hangers shall not be bent.

**5.5.5 Listed Inserts.** The use of listed inserts set in concrete to support hangers shall be permitted.

#### 5.5.6 Powder-Driven Fasteners.

**5.5.6.1** Unless the requirements of 5.5.6.2 are met, powder-driven fasteners shall not be used to attach hangers to the building structure where systems are required to be protected against earthquakes.

**5.5.6.2** The requirements of 5.5.6.1 shall not apply to powder-driven fasteners that are specifically listed for service in seismic areas.

#### 5.6 Nozzles.

**5.6.1\* Listing.** Nozzles shall be listed either individually or as a part of a pre-engineered system, and the listing information shall include the following:

- (1) Specific hazards and protection objectives
- (2) Volumetric flow rate characteristics of water discharge for each nozzle
- (3) Maximum height of protected space
- (4) Minimum distance between nozzle tip or diffuser, as applicable, and plane of protection
- (5) Maximum spacing between nozzles
- (6) Maximum coverage area per nozzle
- (7) Minimum spacing between nozzles
- (8) Maximum height between ceiling and nozzle diffuser or tip, as applicable
- (9) Nozzle obstruction spacing criteria
- (10) Maximum spacing of nozzles from walls
- (11) Minimum- and maximum-rated operating pressures of nozzles

- (12) Allowable range of nozzle orientation angle from vertically down
- (13) Classification of automatic nozzle thermal response characteristics as fast, special, or standard response
- (14) Maximum compartment volume, if applicable
- (15) Maximum time delay for water mist delivery to the most remote nozzle

**5.6.2 New Nozzles.** Only new nozzles shall be installed in water mist systems.

**5.6.3 Marking.** Nozzles shall be permanently marked to identify the manufacturer, type, and size of the orifice(s) or part number.

**5.6.4 Corrosion Protection.** Additional corrosion protection, such as special corrosion-resistant materials or coatings, shall be required in severely corrosive atmospheres.

**5.6.5 Protective Coatings.** Where protective coatings are used to meet the requirements of 5.1.3, the coatings shall be applied by the nozzle manufacturer, and the coated nozzle shall be listed.

**5.6.6 Frangible Discs and Blowoff Caps.**

**5.6.6.1** Where clogging by external, foreign materials is possible, discharge nozzles shall be provided with frangible discs, blowoff caps, or other listed devices.

**5.6.6.2** These devices shall provide an unobstructed opening upon system operation and shall be located so they cannot injure personnel.

**5.6.7 Thermally Activated Nozzles.**

**5.6.7.1** The standard temperature ratings of individual, thermally activated nozzles shall be as shown in Table 5.6.7.1.

**5.6.7.2** Individual, thermally activated nozzles shall be colored in accordance with the color code designated in Table 5.6.7.1.

**5.6.7.3** The stock of spare, individual, thermally activated nozzles shall include all types and ratings installed and shall be as follows:

- (1) For systems having fewer than 50 nozzles, not fewer than 3 nozzles
- (2) For systems having 50 to 300 nozzles, not fewer than 6 nozzles
- (3) For systems having 301 to 1000 nozzles, not fewer than 12 nozzles
- (4) For systems having over 1000 nozzles, not fewer than 24 nozzles

**5.7 Valves.**

**5.7.1 Valve Listing.**

**5.7.1.1** Unless the requirements of 5.7.1.2 are met, all valves shall be listed for their intended use.

**5.7.1.2** The requirements of 5.7.1.1 shall not apply to valves used only for drains or test connections, which shall be permitted to be approved.

**5.7.2 Compatibility.** All gaskets, O-rings, sealants, and other valve components shall be constructed of materials that are compatible with the gas or water and any additives contained in the water.

**5.7.3 Identification of Valves.**

**5.7.3.1** All control, drain, and test connection valves shall be provided with permanently marked, weatherproof, metal or rigid plastic identification signs.

**5.7.3.2** The sign shall be secured with corrosion-resistant wire, chain, or other approved means.

**5.8 Strainers and Filters.**

**5.8.1 Listing.** A system strainer shall be provided downstream of each water supply system, water supply tank, pump, pipe section, fitting, valve, or other piping component having a wetted surface that does not have corrosion resistance equivalent to the materials given in Table 5.3.3.1 or Table 5.4.2.1.

**5.8.2\* Flow, Pressure, and Duration Sizing.** The strainer or filter shall be sized for continuous operation at the required minimum flow and pressure, as verified by hydraulic calculations, for the minimum water supply duration.

**5.8.3 Corrosion Resistance.** Each system strainer shall have corrosion resistance equivalent to the materials given in Table 5.4.2.1.

**5.8.4 Listing.** Pipeline strainers and filters shall be listed for use in water supply connections.

**5.8.5 Flush-Out Connection.** Pipeline strainer and filter designs shall incorporate a flush-out connection.

**5.8.6 Sizing.** Pipeline strainers and filters shall be sized in accordance with 10.5.1.4, 10.5.1.5, and 10.5.1.6.

**Table 5.6.7.1 Temperature Ratings, Classifications, and Color Coding of Individual, Thermally Activated Nozzles**

| Maximum Ambient Temperature |     | Nozzle Temperature Rating |            | Temperature Classification | Color Code         | Glass Bulb Color |
|-----------------------------|-----|---------------------------|------------|----------------------------|--------------------|------------------|
| °C                          | °F  | °C                        | °F         |                            |                    |                  |
| 38                          | 100 | 57 to 77                  | 135 to 170 | Ordinary                   | Uncolored or black | Orange or red    |
| 66                          | 150 | 79 to 107                 | 175 to 225 | Intermediate               | White              | Yellow or green  |
| 107                         | 225 | 121 to 149                | 250 to 300 | High                       | Blue               | Blue             |
| 149                         | 300 | 163 to 191                | 325 to 375 | Extra high                 | Red                | Purple           |
| 191                         | 375 | 204 to 246                | 400 to 475 | Very extra high            | Green              | Black            |
| 246                         | 475 | 260 to 302                | 500 to 575 | Ultra high                 | Orange             | Black            |
| 329                         | 625 | 343                       | 650        | Ultra high                 | Orange             | Black            |



**5.8.7 Nozzle Strainers and Filters.** Individual strainers or filters for water mist nozzles, where required by the manufacturer, shall be listed as a part of a nozzle.

#### 5.8.8 Spare Strainers and Filters.

**5.8.8.1** Spare pipeline and individual nozzle strainers and filters for water mist nozzles, if replaceable, shall be provided and shall include all types and sizes installed.

**5.8.8.2** Spare strainers and filters shall be provided to service the nozzles, if replaceable, for the largest single hazard or group of hazards to be protected simultaneously.

#### 5.9 Pump Systems.

##### 5.9.1 Pumps.

**5.9.1.1 Installation Standard.** Pumps for water mist systems shall be installed in accordance with NFPA 20, *Standard for the Installation of Stationary Pumps for Fire Protection*.

**5.9.1.2 Capacity.** Pumps shall be designed with capacities in accordance with 10.5.2.

##### 5.9.1.3 Overpressure.

**5.9.1.3.1** Pumps capable of overpressurizing the system shall be provided with an approved means of pressure relief to prevent an excessive increase in pressure and temperature.

**5.9.1.3.2** Overpressure shall not exceed the working pressure of the piping system.

**5.9.1.4 Automatic Start.** Pumps shall start automatically upon system actuation.

**5.9.1.5\* Gauges.** Where pump vibrations impact gauge performance, gauges shall be isolated to prevent damage.

**5.9.1.6 Pump Information Plate.** Pump installations shall have a metal plate that contains the following information:

- (1) Rated capacity and rated pressure of each pump
- (2) Capacity of pump assembly with all pumps operating
- (3) Capacity of individual unloader valve where there is one unloader valve per pump
- (4) Capacity of manifold unloader valve where there is one unloader for the entire pump assembly
- (5) Pressure setting for each individual unloader valve

**5.9.1.7 Unloader Valves.** Unloader valves shall be listed or approved as part of the pump assembly.

##### 5.9.2 Power Supply.

**5.9.2.1 Installation Standards.** The power supply for pump drivers shall be installed in accordance with NFPA 20, *Standard for the Installation of Stationary Pumps for Fire Protection*; NFPA 70, *National Electrical Code*, and the manufacturer's listing.

**5.9.2.2 Independent Service Feed.** Power supplies for water mist system pumps shall not be required to be fed by an independent service feed to the building.

**5.9.2.3 Arrangement.** Power supplies for pumps shall be arranged so that if the power supply within the protected facility itself must be disconnected during a fire, the power supply to the pump feeder circuit will not be interrupted.

##### 5.9.3 Controllers.

**5.9.3.1 Listing.** Controllers for pumps shall be listed fire pump controllers or listed limited-service controllers installed

in accordance with NFPA 20, *Standard for the Installation of Stationary Pumps for Fire Protection*.

##### 5.9.3.2 Service-Disconnecting Means.

**5.9.3.2.1** A service-disconnecting means in the feeder circuit to controllers shall be permitted where acceptable to the authority having jurisdiction, provided the disconnecting means is supervised in the proper position in accordance with 5.9.3.2.2.

**5.9.3.2.2** Supervision for proper position shall be by one of the following methods:

- (1) Central station, proprietary, or remote station signaling service
- (2) Local electrical supervision through use of a signaling service that causes a supervisory signal at a constantly attended location
- (3) Locking of the disconnecting means in the proper position, with monthly recorded inspections

#### 5.10 Detection, Actuation, Alarm, and Control Systems.

##### 5.10.1 General.

**5.10.1.1 Installation, Testing, and Maintenance Standards.** Detection, actuation, alarm, and control systems shall be installed, tested, and maintained in accordance with the following protective signaling systems standards as applicable:

- (1) NFPA 70, *National Electrical Code*
- (2) NFPA 72, *National Fire Alarm and Signaling Code*
- (3) CAN/ULC S524-06, *Standard for the Installation of Fire Alarm Systems* (in Canada)
- (4) CAN/ULC S529-02, *Standard for Smoke Detectors for Fire Alarm Systems* (in Canada)

**5.10.1.2 Automatic Systems.** Unless the requirements of 5.10.1.3 are met, where a detection system is used to actuate the water mist system and additive system where used, detection and actuation shall be automatic.

**5.10.1.3 Manual Systems.** The requirements of 5.10.1.2 shall not apply to manual-only actuation systems where approved by the authority having jurisdiction.

##### 5.10.2 Automatic Detection.

**5.10.2.1\* Listing.** Automatic detection shall be by listed equipment installed in accordance with NFPA 72, *National Fire Alarm and Signaling Code*.

**5.10.2.2 Primary and Standby Power.** Adequate and reliable primary and 24-hour minimum standby sources of energy shall be used to provide for operation of the detection, signaling, control, and actuation requirements of the systems.

**5.10.2.3 Existing Detection Systems.** If an existing detection system is used in a new water mist system, the detection system shall comply with the requirements of this standard.

##### 5.10.3 Operating Devices.

**5.10.3.1 Devices.** Operating devices shall include water mist releasing devices or valves, discharge controls, and shutdown equipment necessary for successful performance of the system.

**5.10.3.2 Operating Methods.** Operation shall be by listed mechanical, electrical, or pneumatic equipment. An adequate and reliable source of energy shall be used.

**5.10.3.3 Service Conditions.** Devices shall be designed for the service they are to encounter and shall not be rendered inoperative or susceptible to accidental operation.



**5.10.3.4 Temperature Limitations.** Devices shall be designed to function from  $-29^{\circ}\text{C}$  to  $54^{\circ}\text{C}$  ( $-20^{\circ}\text{F}$  to  $130^{\circ}\text{F}$ ) or shall be marked to indicate temperature limitations.

**5.10.3.5 Emergency Release Device.**

**5.10.3.5.1** An emergency release device for the system shall be provided.

**5.10.3.5.2** The emergency release device shall be activated by a single manual operation.

**5.10.3.5.3** This operation shall be accomplished by a mechanical manual release or by an electrical manual release when the control equipment that monitors the battery voltage level of the standby battery supply indicates a low battery signal.

**5.10.3.5.4** The release shall cause simultaneous operation of automatically operated valves that control agent release and distribution.

**5.10.3.5.5** Unless the requirements of 5.10.3.5.6 are met, the battery shall be sized to accomplish all functions.

**5.10.3.5.6** The requirements of 5.10.3.5 shall not apply to dry and wet pipe systems utilizing individual, thermally activated nozzles.

**5.10.3.6 Manual Release Device.**

**5.10.3.6.1** The manual release device(s) shall be located so as to be accessible at all times.

**5.10.3.6.2** The manual release device(s) shall be of distinct appearance and clearly recognizable for the purpose intended.

**5.10.3.6.3** Operation of any manual release device shall cause the system to operate in accordance with the design or listing.

**5.10.3.6.4** The manual release device(s) shall not require a force of more than 178 N (40 lbf) nor a movement of more than 356 mm (14 in.) to cause activation.

**5.10.3.6.5** At least one manual release device for activation shall be located not more than 1.2 m (4 ft) above the floor.

**5.10.3.6.6** All devices for shutting down supplementary equipment shall be integral parts of the system and shall function with the system in operation.

**5.10.3.6.7** All manual devices shall be identified as to the hazard they protect.

**5.10.3.7\* Supplementary Equipment and Interfaces.** All devices for shutting down supplementary equipment or interface with other systems, necessary for effective operation of the water mist system, such as fuel shutoff and ventilation shutoff, shall be considered integral parts of the system and shall function with the system operation unless specifically permitted by the listing.

**5.10.4 Control Equipment.**

**5.10.4.1 Electrical Control Equipment.** Automatic control equipment shall be listed and installed in accordance with *NFPA 72, National Fire Alarm and Signaling Code*.

**5.10.4.2 Listing.** The control unit shall be listed for release device service.

**5.10.4.3 Pneumatic Control Equipment.**

**5.10.4.3.1\*** Pneumatic control lines shall be protected against crimping and mechanical damage.

**5.10.4.3.2** Unless the requirements of 5.10.4.3.3 or 5.10.4.3.4 are met, pneumatic control lines used to activate the system shall be supervised.

**5.10.4.3.3** The requirements of 5.10.4.3.2 shall not apply to pneumatically operated control lines immediately adjacent to the pressurizing source.

**5.10.4.3.4** The requirements of 5.10.4.3.2 shall not apply to pneumatic control lines from master to slave cylinders that are located in close proximity to one another.

**5.10.4.3.5** The control equipment shall be specifically listed for the number and type of actuating devices utilized, and their compatibility shall have been listed.

**5.11 Compatibility.** All components of pneumatic, hydraulic, or electrical systems shall be compatible.

## Chapter 6 System Requirements

**6.1 General.** Water mist systems shall be described by the following four parameters:

- (1) System application
- (2) Nozzle type
- (3) System operation method
- (4) System media type

**6.2 System Applications.** System applications shall consist of one of the following three categories:

- (1) Local-application systems
- (2) Total compartment application systems
- (3) Zoned application systems

**6.2.1 Local-Application Systems.** Local-application systems shall be designed and installed to provide complete distribution of mist on or around the hazard or object to be protected.

**6.2.1.1** Local-application systems shall be designed to protect an object or a hazard in an enclosed, unenclosed, or open outdoor condition.

**6.2.1.2** Local-application systems shall be actuated by automatic nozzles or by an independent detection system.

**6.2.2 Total Compartment Application Systems.**

**6.2.2.1** Total compartment application systems are designed and installed to provide complete protection of an enclosure or space.

**6.2.2.2\*** The complete protection of an enclosure or space shall be achieved by the simultaneous operation of all nozzles in the space by manual or automatic means.

**6.2.3\* Zoned Application Systems.** Zoned application systems are a subset of the compartment system and are designed to protect a predetermined portion of the compartment by the activation of a selected group of nozzles.

**6.2.3.1** Zoned application systems shall be designed and installed to provide complete mist distribution throughout a predetermined portion of an enclosure or space. This shall be achieved by simultaneous operation of a selected group of nozzles in a predetermined portion of the space by manual or automatic means.

**6.2.3.2** Zoned application systems shall be actuated by automatic nozzles or by an independent detection system.

**6.3 Nozzle Types.** Water mist nozzles shall be classified as one of the following three types:

- (1) Automatic
- (2) Nonautomatic
- (3) Hybrid

#### 6.4 System Requirements.

##### 6.4.1 Deluge Systems.

**6.4.1.1** Deluge systems shall employ nonautomatic nozzles (open) attached to a piping network connected to the fluid supply(ies) through a valve controlled by an independent detection system installed in the same area as the mist nozzles.

**6.4.1.2** When the valve(s) is activated, the fluid shall flow into the piping network and discharge from all nozzles attached thereto.

**6.4.2 Wet Pipe Systems.** Wet pipe systems shall employ automatic nozzles attached to a piping network pressurized with water up to the nozzles.

##### 6.4.3 Preaction Systems.

**6.4.3.1** Preaction systems shall employ automatic nozzles attached to a piping network containing a pressurized gas with a supplemental, independent detection system installed in the same area as the nozzles.

**6.4.3.2** Operation of the detection system shall actuate a tripping device that opens the valve, pressurizing the pipe network with water to the nozzles.

**6.4.3.3** The pressurized piping in all preaction systems shall be supervised to ensure piping integrity.

##### 6.4.4 Dry Pipe Systems.

**6.4.4.1** Dry pipe systems shall employ automatic nozzles attached to a piping network containing a pressurized gas.

**6.4.4.2** The loss of pressure in the piping network shall activate a control valve, which causes water to flow into the piping network and out through the activated nozzles.

**6.5\* Media System Types.** Water mist systems shall be classified by two media system types:

- (1) Single fluid
- (2) Twin fluid

**6.6 Additive Systems.** The additive manufacturer or system provider shall be consulted and performance specifications shall be provided to ensure proper operation and reliability. Where additives are used to enhance fire performance, system proportioning accuracy shall comply with the appropriate standards.

**7.1.4 Mechanical and Chemical Damage.** System components shall be located, installed, or suitably protected so they are not subject to mechanical, chemical, or other damage that could render them inoperative.

**7.1.5 Installation and Testing Procedures.** Manufacturers shall provide installation and testing procedures to ensure that the system is installed and will operate as intended.

#### 7.2 Nozzles.

**7.2.1 General.** Nozzles shall be installed in accordance with the manufacturer's listing.

**7.2.2 Nozzle Height Limitations.** The minimum and maximum heights shall be in accordance with the manufacturer's listing.

**7.2.3 Nozzle Spacing Limitations.** The minimum and maximum distances between nozzles shall be in accordance with the manufacturer's listing.

**7.2.4 Distance from Walls.** The minimum and maximum distance from nozzles to walls or partitions shall be in accordance with the manufacturer's listing.

**7.2.5\* Obstructions to Nozzle Discharge.** The location of nozzles with respect to continuous or discontinuous obstructions shall be in accordance with the manufacturer's listing.

**7.2.6 Distance Below Ceilings.** The distance between the nozzle and the ceiling shall be in accordance with the range (minimum and maximum) identified in the manufacturer's listing.

**7.2.7 Spacing Under Pitched or Curved Surfaces.** The distance between nozzles in or under a pitched or curved surface shall be in accordance with the manufacturer's listing.

#### 7.2.8 Nozzle Protection.

**7.2.8.1** Nozzles subject to mechanical damage shall be protected with listed guards.

**7.2.8.2** Guards shall not significantly reduce the effectiveness of the nozzle.

#### 7.2.9 Escutcheons and Cover Plates.

**7.2.9.1** Escutcheons used in a recessed or flush-type nozzle installation shall be a part of a listed nozzle assembly.

**7.2.9.2** Nonmetallic escutcheons shall be listed.

**7.2.9.3** Cover plates used with concealed nozzles shall be part of the listed assembly.

#### 7.2.10 Thermally Activated Nozzle Temperature Ratings.

**7.2.10.1** Temperature ratings shall be selected as follows:

- (1) Where the maximum ceiling temperature does not exceed 38°C (100°F), ordinary temperature nozzles shall be permitted to be used throughout.
- (2) Where maximum ceiling temperatures exceed 38°C (100°F), nozzles with temperature ratings in accordance with the maximum ambient temperatures of Table 5.6.7.1 shall be used.
- (3) High temperature nozzles shall be permitted to be used throughout.
- (4) Where high temperature nozzles are not utilized throughout, nozzles of intermediate and high temperature classifications shall be installed in specific locations as required by 7.2.10.2.

## Chapter 7 Installation Requirements

**7.1 General.** This chapter provides requirements for the installation of water mist system components.

**7.1.1 Listing.** Listed materials and devices shall be installed in accordance with their listing.

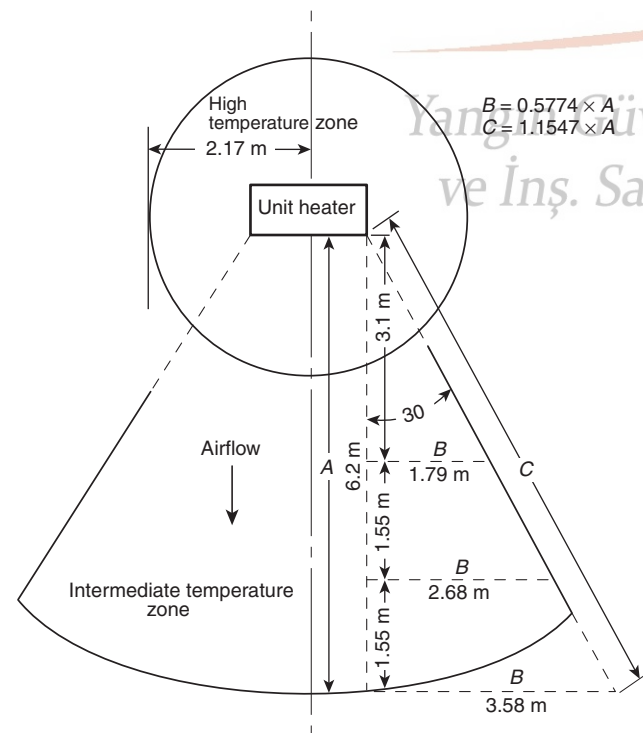
**7.1.2 System Design Manual.** Materials and devices shall be installed in accordance with the system design manual.

**7.1.3 Corrosive Environments.** Systems installed in corrosive environments shall comply with 5.1.3.

**7.2.10.2** The following practices shall be observed to provide nozzles of other than ordinary temperature classification unless other temperatures are determined or unless high temperature nozzles are used throughout. [See Figure 7.2.10.2, Table 7.2.10.2(a), and Table 7.2.10.2(b).]

- (1) Nozzles in the high temperature zone shall be of the high temperature classification, and nozzles in the intermediate temperature zone of the intermediate temperature classification.
- (2) Nozzles located within 305 mm (12 in.) to one side or 762 mm (30 in.) above an uncovered steam main, heating coil, or radiator shall be of the intermediate temperature classification.
- (3) Nozzles within 2.1 m (7 ft) of a low pressure blowoff valve that discharges free in a large room shall be of the high temperature classification.
- (4) Nozzles under glass or plastic skylights exposed to the direct rays of the sun shall be of the intermediate temperature classification.
- (5) Nozzles in an unventilated, concealed space, under an uninsulated roof, or in an unventilated attic shall be of the intermediate temperature classification.
- (6) Nozzles in unventilated show windows having high-powered electric lights near the ceiling shall be of the intermediate temperature classification.
- (7) Nozzles protecting commercial-type cooking equipment and ventilation systems shall be of the high or extra high temperature classification as determined by use of a temperature measuring device.

**7.2.10.3** In case of occupancy change involving temperature change, the nozzles shall be changed accordingly.



For U.S. units: 1 m = 3.23 ft

**FIGURE 7.2.10.2 High Temperature and Intermediate Temperature Zones at Unit Heaters.**

### 7.3 Pipe and Tubing.

**7.3.1 Installation Manual.** Piping and tubing for water mist systems shall be installed in accordance with the manufacturer's installation manual.

**7.3.2 Installation Standards.** All water and atomizing media piping and tubing for water mist systems shall be installed in accordance with one of the following:

- (1) ASME B31.1, *Power Piping Code*
- (2) Water piping only, in low-pressure systems installed in accordance with NFPA 13, *Standard for the Installation of Sprinkler Systems*
- (3) Piping installed in accordance with a water mist system listing where the listing provides installation criteria different from ASME B31.1, *Power Piping Code*

**7.3.3 Pressure Rating.** All system piping, tubing, and hose shall be rated for the maximum working pressure to which they are exposed.

**7.3.4 Listing.** Any flexible piping, tubing, hose, or combination thereof shall be constructed and installed in accordance with the manufacturer's listing.

### 7.3.5 Piping Support.

**7.3.5.1** The system piping shall be supported by structural elements that are independent of the ceiling sheathing to prevent lateral and horizontal movement upon system actuation.

**7.3.5.2** Tube hangers shall be spaced in accordance with Table 7.3.5.2.

**7.3.6 System Drainage.** All system piping and fittings shall be installed so that the entire system can be drained.

### 7.3.7 Location of Hangers and Supports.

**7.3.7.1** Hangers and supports shall be located in accordance with the requirements contained within the system's design manual.

**7.3.7.2** For low pressure and intermediate systems, steel pipe and copper tubing shall be supported in accordance with NFPA 13, *Standard for the Installation of Sprinkler Systems*.

**7.3.7.3** The length of an unsupported arm over to a nozzle shall not exceed 0.6 m (2 ft) for steel pipe or 0.3 m (1 ft) for steel tubing.

**7.3.8\* Protection of System Components Against Damage Where Subject to Earthquakes.** Where subject to earthquakes, water mist systems shall be protected to prevent pipe breakage in accordance with the seismic requirements of NFPA 13, *Standard for the Installation of Sprinkler Systems*.

### 7.4 Fittings.

**7.4.1 Listing.** All system fittings shall be installed in accordance with the manufacturer's listing.

**7.4.2 Low Pressure Systems.** In addition to the requirements of 7.4.1, all fittings installed in low pressure water mist systems shall conform to NFPA 13, *Standard for the Installation of Sprinkler Systems*.

**7.4.3 Pressure Rating.** All fittings shall be rated for the maximum working pressure to which they are exposed.

### 7.5 Gas and Water Storage Containers.

**7.5.1 Listing.** Storage containers shall be installed, mounted, and braced in accordance with the manufacturer's listing.

**Table 7.2.10.2(a) Temperature Ratings of Nozzles Based on Distance from Heat Sources**

| Type of Heat Condition          | Ordinary Degree Rating  | Intermediate Degree Rating  | High Degree Rating  |
|---------------------------------|---|---|---|
| 1. Heating ducts                |   |   |   |
| (a) Above                       | More than 775 mm (2 ft 6 in.)                                     | 775 mm (2 ft 6 in.) or less   |   |
| (b) Side and below              | More than 310 mm (1 ft 0 in.)                                     | 310 mm (1 ft 0 in.) or less   |   |
| (c) Diffuser                    | Any distance except as shown in Intermediate Degree Rating column | <p><i>Downward discharge:</i> Cylinder with 310 mm (1 ft 0 in.) radius from edge, extending 310 mm (1 ft 0 in.) below and 775 mm (2 ft 6 in.) above</p> <p><i>Horizontal discharge:</i> Semi-cylinder with 775 mm (2 ft 6 in.) radius in direction of flow, extending 310 mm (1 ft 0 in.) below and 775 mm (2 ft 6 in.) above</p> |   |
| 2. Unit heater                  |   |   |   |
| (a) Horizontal discharge        |   | <p><i>Discharge side:</i> 2.2 m to 6.2 m (7 ft 0 in. to 20 ft 0 in.) radius pie-shaped cylinder (see Figure 7.2.10.2) extending 2.2 m (7 ft 0 in.) above and 620 mm (2 ft 0 in.) below heater; also 2.2 m (7 ft 0 in.) radius cylinder more than 2.2 m (7 ft 0 in.) above unit heater</p>   | 2.2 m (7 ft 0 in.) radius cylinder extending 2.2 m (7 ft 0 in.) above and 620 mm (2 ft 0 in.) below unit heater                   |
| (b) Vertical downward discharge |   | 2.2 m (7 ft 0 in.) radius cylinder extending upward from an elevation 2.2 m (7 ft 0 in.) above unit heater  | 2.2 m (7 ft 0 in.) radius cylinder extending from the top of the unit heater to an elevation 2.2 m (7 ft 0 in.) above unit heater |
| 3. Steam mains (uncovered)      |   |   |   |
| (a) Above                       | More than 775 mm (2 ft 6 in.)                                     | 775 mm (2 ft 6 in.) or less   |   |
| (b) Side and below              | More than 310 mm (1 ft 0 in.)                                     | 310 mm (1 ft 0 in.) or less   |   |
| (c) Blowoff valve               | More than 2.2 m (7 ft 0 in.)                                      |   | 2.2 m (7 ft 0 in.) or less  |

**Table 7.2.10.2(b) Ratings of Nozzles in Specified Locations**

| Location  | Ordinary Degree Rating     | Intermediate Degree Rating  | High Degree Rating |
|---|----------------------------|---|--------------------|
| Skylights   |                            | Glass or plastic  |                    |
| Attics  | Ventilated                 | Unventilated  |                    |
| Peaked roof: Metal or thin boards, concealed or not concealed, insulated or uninsulated | Ventilated                 | Unventilated  |                    |
| Flat roof: Metal, concealed, insulated or uninsulated                                   | Ventilated or unventilated | Note: For uninsulated roof, climate and occupancy could necessitate intermediate nozzles. Check on job. |                    |
| Flat roof: Metal, concealed, insulated or uninsulated                                   | Ventilated                 | Unventilated  |                    |
| Show windows  | Ventilated                 | Unventilated  |                    |

No reproduction or networking permitted without license from IHS

Table 7.3.5.2 Tube Hanger Maximum Spacing

| Tube O.D. |         | Maximum Distance Between Hangers |      |
|-----------|---------|----------------------------------|------|
| mm        | in.     | m                                | ft   |
| 6-14      | ¼, ⅜, ½ | 1.21                             | 4.0  |
| 15-22     | ¾-7/8   | 1.52                             | 5.0  |
| 23-28     | 1       | 1.82                             | 6.0  |
| 30-38     | 1¼-1½   | 2.12                             | 7.0  |
| 40-49     |         | 2.42                             | 8.0  |
| 50-59     |         | 3.00                             | 10.0 |
| 60-70     |         | 3.33                             | 11.0 |
| 71-89     |         | 3.64                             | 12.0 |
| 90-108    |         | 3.94                             | 13.0 |

**7.5.2 Accessibility.** Storage containers and accessories shall be installed so that inspection, testing, recharging, and other maintenance are facilitated and interruption to protection is held to a minimum.

**7.5.3\* Location.** Storage containers shall be located as close as possible to the hazard or within the hazards they protect and shall not be exposed to fire or mechanical damage in a manner that affects performance.

**7.5.4 Damage.** Storage containers shall be protected from severe weather conditions and from mechanical, chemical, or other damage.

#### 7.5.5 High Pressure Storage Containers.

**7.5.5.1 Standards.** High pressure containers or cylinders shall be constructed, tested, and marked in accordance with recognized international standards, such as the U.S. Department of Transportation, 49 CFR, 171-190, 178.36-178.37, specifications (in effect upon date of manufacture and test) for DOT-3A, 3AA-1800, or higher seamless steel cylinders.

**7.5.5.2 Preshipping Testing.** Charged cylinders shall be tested for tightness before shipment in accordance with an approved procedure.

#### 7.5.5.3 Manifolded Cylinders.

**7.5.5.3.1** Where manifolded, cylinders shall be mounted and supported in a rack provided for this purpose, including facilities for convenient, individual servicing or weighing of contents.

**7.5.5.3.2** When any cylinder is removed for maintenance, automatic means shall be provided to prevent leakage from the manifold if the system is operated.

#### 7.5.5.4 Storage Temperatures.

**7.5.5.4.1** Storage temperatures shall be maintained within the range specified in the manufacturer's listing.

**7.5.5.4.2** External heating or cooling shall be an approved method to keep the temperature of the storage container within desired ranges.

**7.5.5.5 Container Securement.** Containers shall be secured with manufacturer-listed supports to prevent container movement and possible physical damage.

#### 7.5.6 Intermediate and Low Pressure Storage Cylinders.

**7.5.6.1** Unless the requirements of 7.5.6.3 are met, the pressure container shall be made, tested, approved, equipped, and marked in accordance with the current specifications of the ASME *Boiler and Pressure Vessel Code*, Section VIII, or the requirements of U.S. Department of Transportation, 49 CFR, 171-190, 178.36-178.37, or other approved international standards.

**7.5.6.2** The design working pressure shall be in accordance with the manufacturer's listing.

**7.5.6.3** The requirements of 7.5.6.1 shall not apply to pressure containers for heated water mist systems, which shall be in accordance with the manufacturer's listing.

**7.5.6.4** Each pressure container shall be equipped with a liquid level gauge, a pressure gauge, and a high/low pressure supervisory alarm set at the values identified in the manufacturer's listing.

**7.5.6.5** Media storage containers that become pressurized only during system activation shall not require high/low pressure supervisory alarms.

#### 7.5.6.6 Storage Temperature.

**7.5.6.6.1** Storage temperatures shall be maintained within the range specified in the manufacturer's listing.

**7.5.6.6.2** External heating or cooling shall be an approved method to keep the temperature of the storage container within desired ranges.

**7.5.6.7 Securement.** Containers shall be secured with manufacturer-listed supports to prevent container movement and possible physical damage.

#### 7.6 Pumps and Pump Controllers.

**7.6.1\* Sizing.** Pumps shall be sized to meet the required system water flow rate, at the minimum system pressure, as determined by hydraulic calculations.

**7.6.2 Automatic Start.** Pumps shall start automatically and shall supply water to the water mist system until manually shut off or automatically shut off in accordance with the manufacturer's listing.

**7.6.3 Supervisory Service.** Unless the requirements of 7.6.4 are met, pumps shall be provided with supervisory service from a listed central station, proprietary, or remote station system or equivalent.

**7.6.4 Single Family Dwellings.** The requirements of 7.6.3 shall not apply to pumps for single-family dwellings.

**7.6.5 Test Fittings or Hose Outlets.** Pumps shall be equipped with a test fitting or hose outlet on the discharge side of the pump to facilitate the annual full-flow pump test required in Table A.13.2.2.

#### 7.7 Strainers and Filters.

**7.7.1 Location.** Strainers and filters shall be provided at all water supply connections in accordance with Chapter 10.

**7.7.2 Installation.** Filters and strainers shall be installed to minimize potential head loss due to accumulation of particulates.

## 7.8 Valves and Pressure Gauges.

### 7.8.1 General.

**7.8.1.1** All valves shall be installed in accordance with the manufacturer's listing.

**7.8.1.2** Valves having components that extend beyond the valve body shall be installed in a manner that does not interfere with the operation of any system components.

**7.8.1.3** All valves shall be listed for their particular application and installation.

**7.8.1.4** Valves forming part of a listed system shall not be required to be individually listed.

### 7.8.1.5 Valve Identification.

**7.8.1.5.1** All control, drain, and test connection valves shall be provided with permanently marked, weatherproof, metal or rigid plastic identification signs.

**7.8.1.5.2** The sign shall be secured by corrosion-resistant wire or chain or by other approved means.

**7.8.1.6 Valve Accessibility.** System valves and gauges shall be installed such that they are accessible for operation, inspection, and maintenance.

### 7.8.1.7 Indicating Valves.

**7.8.1.7.1** Unless the requirements of 7.8.1.7.2 are met, at least one listed indicating valve shall be installed in each source of water supply.

**7.8.1.7.2** The requirements of 7.8.1.7 shall not apply to systems with a single water supply source comprised of a self-contained system (cylinders, containers).

### 7.8.1.8 Valve Supervision.

**7.8.1.8.1** Valves on connections to water supplies, sectional control and isolation valves, and other valves in supply pipes to nozzles and other fixed water-based fire suppression systems shall be supervised by one of the following methods:

- (1) Central station, proprietary, or remote station signaling service
- (2) Local signaling service that will cause the sounding of an audible signal at a constantly attended point
- (3) Valves locked in the correct position
- (4) Valves located within fenced enclosures under the control of the owner, sealed in the open position, and inspected weekly as part of an approved procedure

**7.8.1.8.2** Valves controlling manual system activation shall not be locked and shall be supervised in accordance with 7.8.1.8.1(1), 7.8.1.8.1(2), or 7.8.1.8.1(3).

### 7.8.2 Control and Activation Valves.

**7.8.2.1** Control and activation valves shall include any device or valve that automatically opens to supply water to the nozzles after the detection of a fire.

**7.8.2.2** Control and activation valves shall operate by an approved mechanical, electrical, or pneumatic means.

**7.8.2.3** Control and activation valves shall be installed such that they are not subject to mechanical, chemical, or other damage that would render them inoperative.

## 7.8.3 Pressure Regulating and Pressure Relief Valves.

### 7.8.3.1 Water Pressure Regulating Valves.

**7.8.3.1.1** Pressure regulating valves shall be installed in any portion of the system where the potential exists for the system pressure to exceed the maximum-rated working pressure of the system or system components, or both.

**7.8.3.1.2** These valves shall open when the system pressure reaches 95 percent of the system-rated pressure.

**7.8.3.1.3** A relief valve of not less than 13 mm (½ in.) shall be provided on the discharge side of the pressure regulating valve that is set to operate at a pressure not exceeding the system-rated pressure.

**7.8.3.1.4** Unless the requirements of 7.8.3.1.5 are met, a listed indicating valve shall be provided on the inlet side of each pressure reducing valve.

**7.8.3.1.5** The requirements of 7.8.3.1.4 shall not apply where the pressure regulating valve meets the listing requirements for use as an indicating valve.

**7.8.3.1.6** A waterflow test valve that is sized to produce the designed flow of the pressure reducing valve shall be installed on the downstream side of the pressure reducing valve.

**7.8.3.1.7** A sign indicating the correct discharge pressure for static and residual pressures shall be attached to the pressure reducing valve.

### 7.8.3.2 Compressed Gas Pressure Regulating Valves (PRVs).

**7.8.3.2.1** PRVs shall be installed in accordance with the manufacturer's listing.

**7.8.3.2.2** PRVs shall be installed when the supply pressure is higher than the design operating pressure of the water mist system.

**7.8.3.2.3** PRVs shall be capable of providing a stable regulating output at the rated flow capacity and design set point over the full range of input pressures that will be experienced over the course of the discharge period.

**7.8.3.2.4** Downstream pressure drift under no-flow conditions shall not exceed the lesser of the downstream components' pressure rating or the pressure relief valve set point, if provided.

**7.8.3.2.5** Pressure set, point-adjusting mechanisms on the PRVs shall be tamper resistant, and the adjustment shall be indicated by a permanent marking.

**7.8.3.2.6** A means to indicate evidence of tampering shall be provided.

**7.8.3.2.7** The PRVs' set point shall be set by the manufacturer.

**7.8.3.2.8** Permanent markings shall indicate the inlet and outlet connections of the PRVs.

### 7.8.4 Check Valves and Backflow Preventers.

**7.8.4.1** Check valves shall be installed in accordance with the manufacturer's listing.

**7.8.4.2** A check valve shall be installed between the system and the point of permanent connection to a potable water supply.

DEKA  
MÜHENDİSLİK  
Yangın Güvenlik Sistemleri

No reproduction or networking permitted without license from IHS

**7.8.4.3** Where additives are used in the water mist system, either by injection into flowing lines or by premixing into stored water sources, a backflow preventer shall be installed between the system control valve or stored water supply and a permanent connection to a potable water supply.

**7.8.4.4** Check valves shall be installed in the main feed lines, near the control valves of both the water and pneumatic system piping of a twin-fluid system, to prevent the backflow of water or atomizing fluid into the companion piping.

**7.8.4.4.1** Where the water and atomizing fluid are separated by an air gap, check valves shall be permitted to be omitted.

### 7.8.5 Pressure Gauges.

**7.8.5.1** Pressure gauges shall be installed in the following locations:

- (1) On both sides of a pressure regulating valve
- (2) On the pressurized side of all supply connections
- (3) On the pressurized side of all system control valves
- (4) On all pressurized storage containers
- (5) On all air supplies for dry pipe and preaction systems
- (6) When multiple gas cylinders are employed with their individual cylinder valves sealed or supervised in the open position and connected to a pressurized manifold, a single pressure gauge on the pressurized section of the manifold shall be permitted for indicating the pressure in all the gas cylinders.

**7.8.5.2** The required pressure gauges shall be compatible with their intended use and shall have an operating range not less than twice the working pressure of the system.

## 7.9 Electrical Systems.

### 7.9.1 Electrical Equipment.

**7.9.1.1** Electrical equipment associated with water mist systems shall be installed in accordance with the requirements of *NFPA 70, National Electrical Code*.

**7.9.1.2\*** All signaling system circuits and wiring shall be installed in accordance with *NFPA 72, National Fire Alarm and Signaling Code*.

**7.9.1.3\*** All signaling line circuits and wiring shall be installed in accordance with *NFPA 72, National Fire Alarm and Signaling Code*, Style 6.

### 7.9.2 Control Equipment.

**7.9.2.1 Installation Standards.** Electrical fire detection and control equipment used to activate water mist systems shall be installed in accordance with the following:

- (1) *NFPA 70, National Electrical Code*
- (2) *NFPA 72, National Fire Alarm and Signaling Code*
- (3) Other approved, recognized standards and the manufacturer's recommendations

**7.9.2.2 Supervision.** All circuitry that is monitoring or controlling the water mist system shall be electrically supervised in accordance with *NFPA 72, National Fire Alarm and Signaling Code*.

**7.9.2.3 Primary and Standby Power.** Approved primary and 24-hour minimum standby sources of energy shall be used to provide for the operation of the detection, signaling, control, and actuation requirements of the system.

### 7.9.2.4 Alarms.

**7.9.2.4.1** Alarms shall be provided to indicate system water-flow and system trouble.

**7.9.2.4.2** Trouble and supervisory signals shall include power failure, operation (closing) of monitored valving, and electrical faults in the detection/activation of pump power control systems.

**7.9.2.4.3** These alarms shall be both visible and audible inside the protected space, at the location of the primary system components (e.g., pumps, storage tanks), and in a continuously attended location.

**7.9.2.4.4** The system activation alarm shall be distinctly different from the system trouble signal to prevent confusion.

### 7.9.3 Fire Detection.

**7.9.3.1\*** Where electrically operated automatic fire detection systems are used, the installation shall be in accordance with *NFPA 72, National Fire Alarm and Signaling Code*.

**7.9.3.2** Approved primary and 24-hour minimum standby sources of energy shall be used to provide for operation of the detection, signaling, control, and actuation requirements of the system.

**7.9.3.3** Where a new water mist system is installed in a space that has an existing detection system, an analysis shall be made of the detection devices to ensure that the detection system meets the requirements of the water mist system listing and that the detection system is in operating condition.

### 7.9.4 Automatic and Manual Activation.

**7.9.4.1** Unless the requirements of 7.9.4.2 are met, a means of automatic operation of the water mist system shall be provided.

**7.9.4.1.1** Automatic operation shall be accomplished by means of automatic nozzles (independently thermally activated), automatic group control valves, or an independent automatic fire detection system, coupled with a listed system activation panel.

**7.9.4.2** The requirements of 7.9.4.1 shall not apply to manual-only actuation systems where approved by the authority having jurisdiction.

**7.9.4.3** A means of manual release of the system shall be installed and arranged in accordance with 5.10.3.

### 7.10 Test Connections.

**7.10.1\*** A test connection shall be provided at the most hydraulically remote point on the water mist system.

**7.10.2** The inside diameter shall not be less than the largest orifice diameter used in the water mist system.

**7.10.3** Discharge from the test connection shall be piped to a safe discharge location.

**7.10.4** Where occupancy conditions prohibit water from being discharged from the most hydraulically remote point, a test connection shall be provided immediately upstream of each hazard area protected.

## Chapter 8 Design Objectives and Fire Test Protocols

### 8.1\* General.

**8.1.1 Listing.** Water mist protection systems shall be designed and installed for the specific hazards and protection objectives specified in the listing.

**8.1.2 Application Characteristics.** The characteristics of the specific application (compartment variables and hazard classification) shall be consistent with the listing of the system.

**8.1.3 Application Evaluations.** An evaluation of the compartment geometry, fire hazard, and system variables described in this chapter shall be performed to ensure that the system design and installation are consistent with the system listing.

**8.1.4 Pre-Engineered Systems.** Pre-engineered water mist systems for compartment enclosures shall not be extrapolated beyond the volume, ceiling height, ventilation rate, and number of nozzles tested, unless dimensions of the enclosure are such that additional nozzles are required to maintain nozzle spacing.

## 8.2\* Listing Evaluations.

**8.2.1 Scope.** Listing of water mist fire protection systems shall be based on a comprehensive evaluation designed to include fire test protocols, system components, and the contents of the manufacturer's design and installation manual.

**8.2.2\* Fire Test Protocols.** Fire test protocols shall be designed to address performance objectives of the application specified in the listing and the application parameters described in Section 8.4.

## 8.2.3 Application Parameters.

**8.2.3.1** Application parameters shall be the features that define an application.

**8.2.3.2** Application parameters shall include compartment variables (such as height, volume, obstructions, and ventilation), fire hazard (fuel type and configuration), and occupancy, with consideration of performance objectives specific to the application.

## 8.2.4 Applicability.

**8.2.4.1** Fire test protocols shall be designed to replicate the range of the application parameters associated with a particular hazard or occupancy.

**8.2.4.2** The system hardware shall be listed for the intended application.

**8.2.5 Testing.** Test protocols shall be conducted to verify the working limits and installation parameters of the system and its components, as described in the manufacturer's design and installation manual.

## 8.2.6 Design and Installation Manual.

**8.2.6.1** The system design and installation manual evaluated by the listing tests shall identify the working limits and parameters of the system, the fire hazards, and the range of compartment variables for which the listing is applicable.

**8.2.6.2** It shall also include recommended installation, testing, inspection, and maintenance procedures and, by reference, the requirements of NFPA 750, *Standard on Water Mist Fire Protection Systems*.

## 8.3 Performance Objectives.

**8.3.1\* Fire Performance Objectives.** The fire-fighting performance objectives of a water mist system shall be described using at least one of the following three terms:

- (1) Control
- (2) Suppression
- (3) Extinguishment

**8.3.1.1 Fire Control.** Fire control shall be measured using three basic approaches:

- (1) A reduction in the thermal exposure to the structure, where the primary objective is to maintain the structural integrity of the building (e.g., prevent flashover)
- (2) A reduction in the threat to occupants, where the primary objective is to minimize the loss of life
- (3) A reduction in a fire-related characteristic, such as heat release rate, fire growth rate, or spread to adjacent objects

**8.3.1.2 Fire Suppression.** Fire suppression is the sharp reduction in the heat release rate of a fire and the prevention of its regrowth by a sufficient application of water mist.

**8.3.1.3 Fire Extinguishment.** Fire extinguishment is the complete suppression of a fire until there are no burning combustibles.

## 8.4 Application Parameters.

**8.4.1\* Compartment Variables.** Compartment variables shall include both the geometry of the compartment and the ventilation conditions in the compartment.

**8.4.1.1 Compartment Geometry.** The compartment geometry (floor area, compartment volume, ceiling height, and aspect ratio) shall be considered when designing such parameters as nozzle locations, system flow rate, and total water use needs of the system.

**8.4.1.2 Ventilation.** Ventilation considerations shall include both natural and forced ventilation parameters.

### 8.4.1.2.1\* Natural Ventilation.

**8.4.1.2.1.1** The number, size, and location of the openings in the space (e.g., door, windows) shall be addressed in the design and installation of the system.

**8.4.1.2.1.2** In some cases, special precautions shall be given to minimize the effects of these openings, including, but not limited to, automatic door closures and water mist curtains.

### 8.4.1.2.2 Forced Ventilation.

**8.4.1.2.2.1** The magnitude of the forced ventilation in the compartment shall be addressed in the design and installation of the water mist system.

**8.4.1.2.2.2** In some cases, consideration shall be given to shutting down the forced ventilation prior to mist system activation.

**8.4.2 Fire Hazard Classification.** The fire hazard shall be classified by both the combustible loading and fuel type.

### 8.4.2.1 Combustible Loading.

**8.4.2.1.1** A fire hazard analysis shall be conducted to determine both the design parameters of the water mist system and the type of detection and activation scheme employed by the system.

**8.4.2.1.2** The system shall be based on the fuel type, combustible loading, and anticipated fire growth rate as well as the desired fire-fighting performance objectives.

### 8.4.2.2 Fuel Type.

**8.4.2.2.1** Overall fire hazard shall be directly related to the type and quantity of the fuel present in a space.

**8.4.2.2.2** The ease of ignition and reignition of the fuel, the fire growth rate, and the difficulty of achieving control, suppression, extinguishment, or any combination thereof, shall be considered when selecting or designing a water mist system.



### 8.4.2.2.3 Class A Fires.

**8.4.2.2.3.1** Fuel loading and configuration shall be considered when selecting and designing a system to protect a space or area containing Class A materials.

**8.4.2.2.3.2** If fire extinguishment is desired, consideration shall be given to the potential for deep-seated fires as well as to the potential for smoldering fires.

### 8.4.2.2.4 Class B Fires.

**8.4.2.2.4.1** The hazard associated with Class B fires shall be related primarily to the fuel loading, fuel configuration, flashpoint, and burning rate of the fuel.

**8.4.2.2.4.2** Preburn time shall be evaluated as it affects the overall characteristics of the fire.

**8.4.2.2.4.3** Class B fires shall be grouped into two categories: two-dimensional pool fires and three-dimensional spray and running fuel fires. The parameters associated with each category shall be as follows:

- (1) Class B two-dimensional fires
  - (a) Fuel loading and configuration
  - (b) Fuel flashpoint
  - (c) Preburn time pool/spill size
- (2) Class B three-dimensional fires
  - (a) Fuel loading and configuration
  - (b) Fuel flashpoint
  - (c) Preburn time
  - (d) Cascade/running fuel fires
  - (e) Fuel flow rate
  - (f) Fire configuration
  - (g) Spray fires
  - (h) Fuel line pressure
  - (i) Fuel spray angle
  - (j) Fuel spray orientation
  - (k) Reignition sources

**8.4.2.2.4.4** When designing and installing water mist systems to protect Class B hazards, the parameters specified in 8.4.2.2.4.3(1) and (2) shall be considered.

**8.4.2.2.5 Class C Fires.** Electrical conductivity of water and water mist shall be addressed when considering applications where the primary fire is a Class C fire.

**8.4.2.2.6 Combination Fires.** Combinations in fuel loadings and hazards shall be addressed.

**8.4.3 Fire Location.** The location of the fuel in the space shall be considered when selecting and designing a water mist system, including the following:

- (1) Fuel located at higher elevations in the space
- (2) Fuel located in close proximity to vent openings
- (3) Fuel located in the corners of the space
- (4) Fuel stacked against walls

### 8.4.4 Obstructions and Shielding.

**8.4.4.1** Water mist nozzles shall be positioned to distribute mist to all locations in the area or around the object being protected.

**8.4.4.2** The presence of obstructions and the potential for shielding of misting spray patterns shall be evaluated to ensure that the system performance is not affected.

**8.5 Reliability.** See Annex D.

## Chapter 9 Calculations

### 9.1 General.

**9.1.1 Flow Calculation Procedures.** System flow calculation procedures for water mist systems shall be in accordance with one of the following, as applicable:

- (1) Hydraulic calculations shall be performed using the method provided in Section 9.2.
- (2) Hydraulic calculations for systems with no additives and with working pressures not exceeding 12 bar (175 psi) shall be permitted to be performed utilizing either the method provided in Section 9.2 or the method provided in Section 9.3.
- (3) Calculations for piping carrying atomizing media in twin-fluid systems shall be performed in accordance with Section 9.4.

**9.1.2\* Modifications.** Where any modification is made that alters the system flow characteristics of an existing, engineered water mist system, system flow calculations shall be furnished indicating the previous design, volume, and pressure at points of connection, and calculations also shall be provided to indicate the effect on existing systems.

**9.1.3 Pre-Engineered Systems.** Pre-engineered systems shall not be modified outside the limits of the listing.

**9.1.4\* Special Valves, Strainers, and Other Devices.** Specific friction loss values or equivalent pipe lengths for special valves, strainers, and other devices shall be made available to the authority having jurisdiction.

### 9.2\* Darcy-Weisbach Calculation Method for Intermediate and High Pressure, Single Fluid, Single Liquid Phase Systems.

**9.2.1** Pipe friction losses shall be determined by one of the following methods:

- (1) Using the formulas in Table 9.2.1.
- (2) Hydraulic calculations shall be permitted to be performed using the Hazen-Williams calculation method for intermediate and high pressure systems having a minimum 20 mm (¾ in.) pipe size, provided that the maximum flow velocity through the system piping does not exceed 7.6 m/s (25 ft/sec).

**9.2.2\*** The Moody diagram in Figure 9.2.2 shall be used to determine the value of the friction factor,  $f$ , in the Darcy-Weisbach equation, where the Reynolds number and relative roughness are calculated as shown in Table 9.2.1, using coefficients provided in Table 9.2.2(a) and Table 9.2.2(b).

**9.2.3** Minimum and maximum operating pressures at each nozzle shall be within the listed operating range.

**9.2.4** System piping shall be hydraulically designed to deliver the waterflow requirements in accordance with the manufacturer's listing and the provisions of Chapter 8.

### 9.3\* Hazen-Williams Calculation Method (Low Pressure Systems).

**9.3.1 Working Pressure Limits and Additives.** Hydraulic calculations for water mist systems with working pressures not exceeding 12 bar (175 psi) and having no additives shall be permitted to be performed using the Hazen-Williams calculation method.



**Table 9.2.1 Darcy-Weisbach and Associated Equations for Pressure Loss in Intermediate and High Pressure Systems**

|                                | SI Units                                    | U.S. Customary Units                         |
|--------------------------------|---|--|
| <b>Darcy-Weisbach equation</b> | $\Delta p_m = 2.252 \frac{fL\rho Q^2}{d^5}$ | $\Delta p = 0.000216 \frac{fL\rho Q^2}{d^5}$ |
| <b>Reynolds number</b>         | $Re = 21.22 \frac{Q\rho}{d\mu}$             | $Re = 50.6 \frac{Q\rho}{d\mu}$               |
| <b>Relative roughness</b>      | Relative roughness = $\frac{\epsilon}{d}$   | Relative roughness = $\frac{\epsilon}{D}$    |

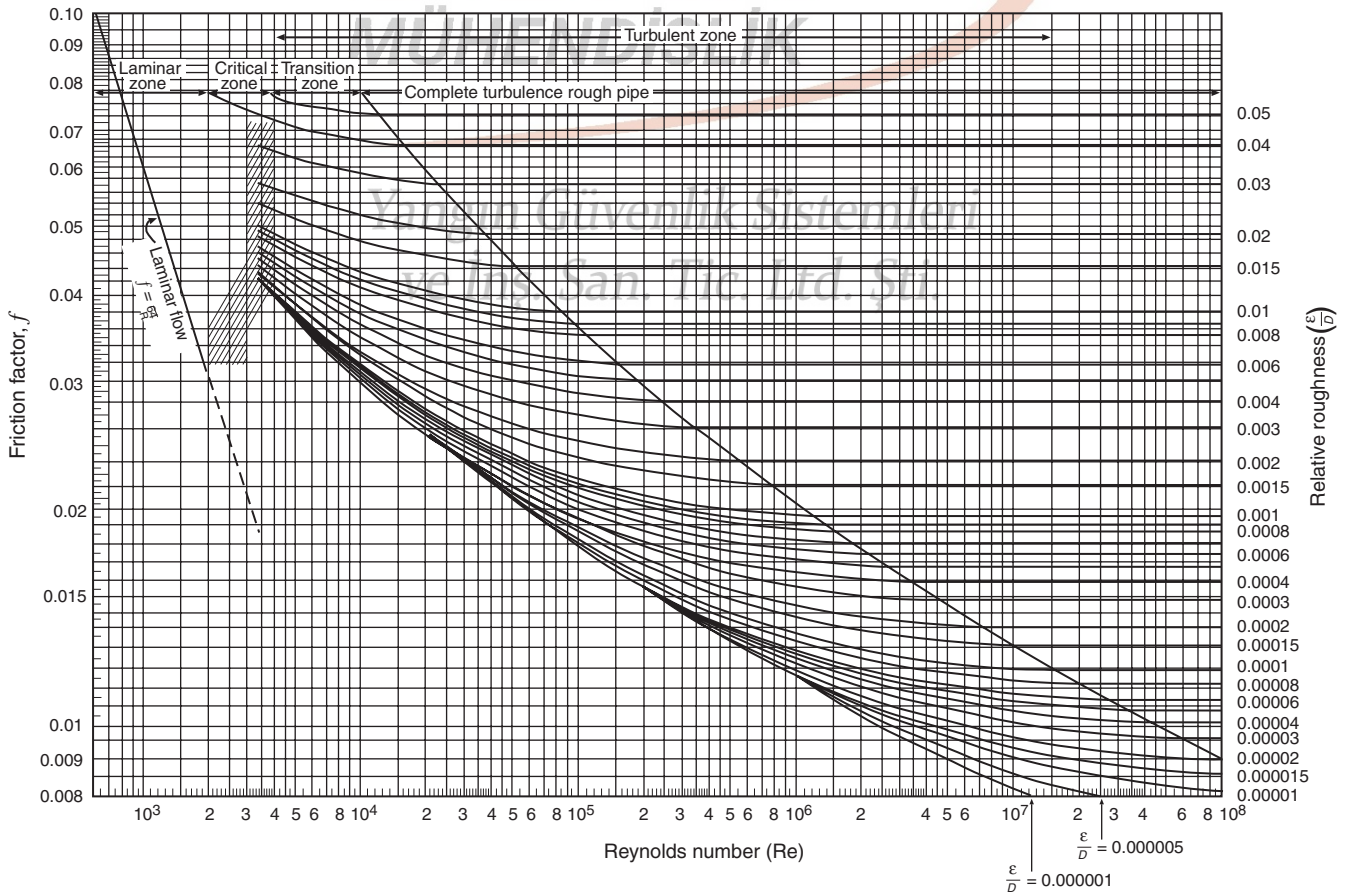
where:

- $\Delta p_m$  = friction loss (bar gauge)
- $L$  = length of pipe (m)
- $f$  = friction factor (bar/m)
- $Q$  = flow (L/min)
- $d$  = internal pipe diameter (mm)
- $\epsilon$  = pipe wall roughness (mm)
- $\rho$  = weight density of fluid (kg/m<sup>3</sup>)
- $\mu$  = absolute (dynamic) viscosity [centipoise (cP)]

where:

- $\Delta p$  = friction loss (psi gauge)
- $L$  = length of pipe (ft)
- $f$  = friction factor (psi/ft)
- $Q$  = flow (gpm)
- $d$  = internal pipe diameter (in.)
- $D$  = internal pipe diameter (ft)
- $\epsilon$  = pipe wall roughness (ft)
- $\rho$  = weight density of fluid (lb/ft<sup>3</sup>)
- $\mu$  = absolute (dynamic) viscosity [centipoise (cP)]

No reproduction or networking permitted without license from IHS



**FIGURE 9.2.2** Moody Diagram.

**Table 9.2.2(a) Recommended Values of Absolute Roughness or Effective Height of Pipe Wall Irregularities, for Use in Darcy-Weisbach Equation**

| Pipe Material  | Design Value of Epsilon |           | H-W equivalent (C factor) |
|--|-------------------------|-----------|---------------------------|
|  | mm                      | ft        |                           |
| Copper, copper nickel                                  | 0.0015                  | 0.000 005 | 150                       |
| Stainless steel drawn tubing (claimed by manufacturer) | 0.0009                  | 0.000 003 | 160                       |
| Stainless steel pipe (= wrought iron pipe)             | 0.0451                  | 0.000 15  | 140                       |

**Table 9.2.2(b) Approximate Values of  $\mu$ , Absolute (Dynamic) Viscosity, and for Clean Water, over the Temperature Range 4.4°C to 37.8°C (40°F to 100°F)**

| Temperature |     | Weight Density of Water |                    | Absolute (Dynamic) Viscosity, $\mu$ (centipoise) |
|-------------|-----|-------------------------|--------------------|--|
| °C          | °F  | kg/m <sup>3</sup>       | lb/ft <sup>3</sup> |  |
| 4.4         | 40  | 999.9                   | 62.42              | 1.5  |
| 10.0        | 50  | 999.7                   | 62.38              | 1.3  |
| 15.6        | 60  | 998.8                   | 62.34              | 1.1  |
| 21.1        | 70  | 998.0                   | 62.27              | 0.95   |
| 26.7        | 80  | 996.6                   | 62.19              | 0.85   |
| 32.2        | 90  | 995.4                   | 62.11              | 0.74   |
| 37.8        | 100 | 993.6                   | 62.00              | 0.66   |

**9.3.2 Friction Loss Formula.** Friction losses for water-filled pipe shall be determined on the basis of the Hazen-Williams formula, as follows:

(1) For SI units:

$$P_m = 6.05 \frac{Q_m^{1.85}}{C^{1.85} d_m^{4.87}} \times 10^5$$

where:

- $P_m$  = frictional resistance (bar/m of pipe)
- $Q_m$  = flow (L/min)
- $d_m$  = actual internal diameter of pipe (mm)
- $C$  = friction loss coefficient

(2) For U.S. customary units:

$$P_f = \frac{4.52Q^{1.85}}{C^{1.85} d^{4.87}}$$

where:

- $P_f$  = frictional resistance (psi/ft of pipe)
- $Q$  = flow (gpm)
- $d$  = actual internal diameter of pipe (in.)
- $C$  = friction loss coefficient

**9.3.3 Velocity Pressure Formula.** Velocity pressure for water-filled pipe shall be determined on the basis of the following formula:

(1) For SI units:

$$P_v = 5.61(10)^{-7} \frac{Q^2}{D^4}$$

where:

- $P_v$  = velocity pressure (bar)
- $Q$  = flow (L/min)
- $D$  = inside diameter (mm)

(2) For U.S. customary units:

$$P_v = \frac{0.001123Q^2}{D^4}$$

where:

- $P_v$  = velocity pressure (psi)
- $Q$  = flow (gpm)
- $D$  = inside diameter (in.)

**9.3.4 Normal Pressure Formula.** Normal pressure,  $P_n$ , shall be determined on the basis of the following formula:

$$P_n = P_t - P_v$$

where:

- $P_n$  = normal pressure [bar (psi)]
- $P_t$  = total pressure [bar (psi)]
- $P_v$  = velocity pressure [bar (psi)]

**9.3.5 Hydraulic Junction Points.**

**9.3.5.1** Pressures at hydraulic junction points shall balance within 0.03 bar (0.5 psi).

**9.3.5.2** The highest pressure at the junction point and the total flows as adjusted shall be used in the calculations.

**9.3.6 Equivalent Pipe Lengths of Valves and Fittings.**

**9.3.6.1** Table 9.3.6.1 shall be used to determine the equivalent length of pipe for fittings and devices, unless the manufacturer's test data indicate that other factors are appropriate.

**9.3.6.2** For saddle-type fittings having friction loss greater than that shown in Table 9.3.6.1, the increased friction loss shall be included in hydraulic calculations.

**9.3.6.3** For internal pipe diameters that differ from copper tubing, the equivalent feet shown in Table 9.3.6.1 shall be multiplied by a factor derived from the following formula. The factor thus obtained shall be modified further in accordance with Table 9.3.6.4.2.

$$\left[ \frac{\text{Actual inside diameter}}{\text{Type K copper tube I.D.}} \right]^{1.87} = \text{Factor}$$

**9.3.6.4 C Factor Values.**

**9.3.6.4.1** Table 9.3.6.1 shall be used with the Hazen-Williams formula only where  $C = 150$ .

**9.3.6.4.2** For  $C$  values other than  $C = 150$ , the values in Table 9.3.6.1 shall be multiplied by the factors in Table 9.3.6.4.2.

**9.3.6.5** Pipe friction loss shall be calculated in accordance with the Hazen-Williams formula  $C$  values from Table 9.3.6.5.

**Table 9.3.6.1 Equivalent Length of Pipe for Copper Fittings and Valves**

| Nominal or Standard Size | Fittings     |      |      |      |             |      |              |      | Valves   |      |      |           |       |      |     |  |
|--------------------------|--------------|------|------|------|-------------|------|--------------|------|----------|------|------|-----------|-------|------|-----|--|
|                          | Standard Ell |      |      |      | 90° Tee     |      |              |      | Coupling | Ball | Gate | Butterfly | Check |      |     |  |
|                          | 90°          |      | 45°  |      | Side Branch |      | Straight Run |      |          |      |      |           |       |      |     |  |
| mm                       | in.          | m    | ft   | m    | ft          | m    | ft           | m    | ft       | m    | ft   | m         | ft    |      |     |  |
| 9.53                     | ¾            | 0.15 | 0.5  | —    | —           | 0.46 | 1.5          | —    | —        | —    | —    | —         | —     | 0.46 | 1.5 |  |
| 12.7                     | ½            | 0.31 | 1    | 0.15 | 0.5         | 0.61 | 2            | —    | —        | —    | —    | —         | —     | 0.61 | 2   |  |
| 15.88                    | ¾            | 0.46 | 1.5  | 0.15 | 0.5         | 0.61 | 2            | —    | —        | —    | —    | —         | —     | 0.76 | 2.5 |  |
| 19.05                    | ¾            | 0.61 | 2    | 0.15 | 0.5         | 0.91 | 3            | —    | —        | —    | —    | —         | —     | 0.91 | 3   |  |
| 25.4                     | 1            | 0.76 | 2.5  | 0.31 | 1           | 1.37 | 4.5          | —    | —        | —    | —    | —         | —     | 1.37 | 4.5 |  |
| 31.75                    | 1¼           | 0.91 | 3    | 0.31 | 1           | 1.68 | 5.5          | 0.15 | 0.5      | 0.15 | 0.5  | —         | —     | 1.68 | 5.5 |  |
| 38.1                     | 1½           | 1.22 | 4    | 0.46 | 1.5         | 2.13 | 7            | 0.15 | 0.5      | 0.15 | 0.5  | —         | —     | 1.98 | 6.5 |  |
| 50.8                     | 2            | 1.68 | 5.5  | 0.61 | 2           | 2.74 | 9            | 0.15 | 0.5      | 0.15 | 0.5  | 0.15      | 0.5   | 2.74 | 9   |  |
| 63.5                     | 2½           | 2.13 | 7    | 0.76 | 2.5         | 3.66 | 12           | 0.15 | 0.5      | 0.15 | 0.5  | —         | —     | 3.66 | 12  |  |
| 76.2                     | 3            | 2.74 | 9    | 1.07 | 3.5         | 4.57 | 15           | 0.31 | 1        | 0.31 | 1    | —         | —     | 4.57 | 15  |  |
| 88.9                     | 3½           | 2.74 | 9    | 1.07 | 3.5         | 4.27 | 14           | 0.31 | 1        | 0.31 | 1    | —         | —     | 4.27 | 14  |  |
| 101.6                    | 4            | 3.81 | 12.5 | 1.52 | 5           | 6.40 | 21           | 0.31 | 1        | 0.31 | 1    | —         | —     | 6.40 | 21  |  |

Notes:

1. Allowances are for streamlined, soldered fittings and recessed threaded fittings. For threaded fittings, double the allowances shown.
2. The equivalent lengths presented in the table are based on a C factor of 150 in the Hazen–Williams friction loss formula. The lengths shown are rounded to the nearest half foot.

**Table 9.3.6.4.2 C Value Multiplier**

| Value of C         | 100   | 120   | 130   | 140   |
|--------------------|-------|-------|-------|-------|
| Multiplying factor | 0.472 | 0.662 | 0.767 | 0.880 |

Note: The multiplying factor is based on the friction loss through the fitting being independent of the C factor available to the piping.

**Table 9.3.6.5 Hazen–Williams C Values**

| Pipe or Tube                                      | C Value* |
|---|----------|
| Plastic (listed per 5.3.2 or 5.3.4.4) — all types | 150      |
| Copper tube or stainless steel                    | 150      |

\* The authority having jurisdiction is permitted to consider other C values.

**9.4 Calculation Procedures for Propellant Gas or Atomizing Media.**

**9.4.1 General.**

**9.4.1.1 Calculations.** Calculations shall be performed to determine the maximum and minimum pneumatic pressures and flow rates (at standard temperature and pressure) at the atomizing media inlet of each twin-fluid nozzle in a multi-nozzle system.

**9.4.1.2 Maximum and Minimum Pressures.** Maximum and minimum pressures at each nozzle shall be within the performance tolerances for the nozzle, as provided by the nozzle manufacturer.

**9.4.1.3 Volume (Gas Quantity) and Pressure.** The volume (gas quantity) and pressure of the supply of propellant gas or atomizing media shall be determined in accordance with either 9.4.1.3.1 or 9.4.1.3.2.

**9.4.1.3.1 Pre-Engineered Systems.** The gas quantity and pressure shall be provided in accordance with the system listing.

**9.4.1.3.2 Engineered Systems.** The gas quantity and pressure shall be determined by full-scale discharge tests with verification of system pressure, calculations provided in accordance with 9.4.2, or manufacturer’s data derived from experience testing.

**9.4.2 Calculation Procedure.**

**9.4.2.1** A pneumatic calculation procedure shall be based on standard engineering methods for sizing of compressed air piping systems.

**9.4.2.2** The gas and water ratios and operating pressures for all nozzles in the system shall be within the manufacturer’s listed limitations.

**9.4.2.3** To start the calculation, the air pressure and airflow rate at the hydraulically most remote nozzle shall be set at the optimum air pressure and airflow rate for the corresponding water pressure and waterflow rate at that nozzle.

**9.4.3 Initial Pressure.**

**9.4.3.1** The initial water pressure condition at the most hydraulically remote nozzle shall be taken from hydraulic calculations performed independently (i.e., treating the water piping as a single fluid system), using assumed nozzle discharges.

**9.4.3.2** Once the water pressure and waterflow rates at each nozzle are determined, the corresponding required air pressure and airflow rate to allow the assumed waterflow rate shall be estimated from information provided by the nozzle manufacturer.

**9.4.4 Verification.**

**9.4.4.1** Having determined the nominal air pressure and flow requirements at each nozzle, the pneumatic piping system shall be calculated independently to verify that the pipe sizes are adequate to provide the required pressure and flow at each nozzle location.

**9.4.4.2** Using the calculated pressures at each nozzle, the effect on the water discharge rate shall be checked.

**9.4.4.3** Where the waterflow rate at the calculated air pressure is within 10 percent of the assumed flow rate in 9.4.3, no correction is required.

**9.4.4.4** Where the waterflow rate at the calculated air pressure is not within 10 percent of the assumed flow rate in 9.4.3, the nozzle discharge shall be adjusted, and the hydraulic calculation of 9.4.3 shall be repeated.

**9.4.4.5** This procedure is iterative and shall be repeated until calculated air and water pressures are within the desired range and ratio.

**9.4.5 Air Pressure to Water Pressure Ratio.** The ratio of the air pressure to water pressure at each nozzle shall be maintained within 10 percent of the manufacturer's recommended operating ratio as provided by the nozzle manufacturer.

**9.4.6 Results.** The results of the hydraulic and pneumatic calculations shall indicate the total water demand as a flow rate and pressure at the system supply point and the total airflow rate (in L/min [scfm]) and initial air pressure at the atomizing media supply point.

## Chapter 10 Water Supplies and Atomizing Media

### 10.1 General.

**10.1.1** Unless otherwise specified, the requirements in this chapter shall apply to the water supplies, the atomizing media, and any additives necessary for fire-extinguishing performance.

**10.1.2** Every water mist system shall have at least one automatic water supply.

**10.1.3\*** Compressed gas or other atomizing medium, where used as part of a twin-fluid water mist system, shall be automatically supplied in concurrence with the water.

**10.2\* Quantity.** The minimum quantities of water, water additives in listed concentrations (if used), and atomizing media (if used) shall be capable of supplying the largest single hazard or group of hazards to be protected simultaneously.

### 10.3\* Duration.

**10.3.1** Design quantities of water, additives (if used), and atomizing media (if used) shall be capable of supplying the system in accordance with one of the following, as applicable:

- (1) A minimum duration of 30 minutes.
- (2) For pre-engineered systems, the design quantities of water, additives (if used), and atomizing media (if used) shall be capable of two complete discharges, or as required by the manufacturer's listing requirements, minimum 2 times the period to extinguish the fires during test, the rundown time of turbine, or the time necessary to secure fuel lines to the rotating equipment, whichever is greater.
- (3) Specific hazard evaluation.
  - (a) Where the hazard has been evaluated by a fire protection engineer using standard methods of fire hazard analysis, the water supply duration shall be determined by the specified performance characteristics of the water mist system.

- (b) It shall be permitted for this method to result in water supply duration requirements greater than or less than those specified in 10.3.1(1).

**10.3.2** Pumps' suction supply shall be sized to supply the actual delivered flow rate for the required duration at the required pressure.

### 10.4 Reserve Supplies.

**10.4.1\*** A reserve supply shall be provided where the extinguishing agent expellant gas or atomizing media cannot otherwise be replaced within 24 hours following system operation.

**10.4.2** A reserve supply shall not be required for pre-engineered water mist systems that meet the requirement for a 30-minute minimum duration, unless otherwise required by the authority having jurisdiction.

**10.4.3** Where a reserve supply is provided and a manual changeover is necessary, the mechanism shall be accessible from outside the protected space.

**10.4.4** Where a reserve supply is provided and no manual changeover is required, it shall be connected to the system piping at all times.

**10.4.5** Means shall be provided to prevent discharge of reserve supplies from open manifold connections when supplies are removed for servicing.

### 10.5 Water Supplies.

#### 10.5.1\* Water Quality.

**10.5.1.1** Unless the requirements of 10.5.1.2 or 10.5.1.3 are met, the water supply for a water mist system shall be taken from a source that is equivalent in quality to a potable source with respect to particulate and dissolved solids or from a source of natural seawater.

**10.5.1.2** The requirements of 10.5.1.1 shall not apply in areas that are normally occupied, where liquid or dissolved chemicals shall be permitted to be added to the water supplies in accordance with the listing, provided they are used at concentrations for which the manufacturer can demonstrate to the satisfaction of the U.S. Environmental Protection Agency that no adverse toxicologic or physiologic effects have been observed.

**10.5.1.3** The requirements of 10.5.1.1 shall not apply to systems that protect normally unoccupied areas, where liquid or dissolved chemicals shall be permitted to be added to the water supplies in accordance with the listing.

#### 10.5.1.4 Filters and Strainers — Nozzles.

**10.5.1.4.1** Unless the requirements of 10.5.1.4.2 are met, a filter or strainer shall be provided at the supply side of each nozzle.

**10.5.1.4.2** The requirements of 10.5.1.4.1 shall not apply to nozzles with multiple orifices and with minimum waterway dimensions greater than 800  $\mu\text{m}$  per opening.

#### 10.5.1.5 Filters and Strainers — Water Supply Connection and Risers.

**10.5.1.5.1** A filter or a strainer shall be provided at each water supply connection or system riser.

**10.5.1.5.2** The filter or strainer shall be installed downstream (on the system side) of all piping that is not corrosion resistant.



**10.5.1.5.3** A filter or strainer with mesh openings meeting the requirements of 10.5.1.6 shall be installed downstream (on the system side) of any reservoirs of stored water or break tank with an air-water interface greater than 1 m<sup>2</sup>.

**10.5.1.5.4** Such strainers shall be provided with a cleanout port and shall be arranged to facilitate inspection, maintenance, and replacement.

**10.5.1.6 Filter Rating or Strainer Mesh Openings.** The maximum filter rating or strainer mesh opening shall be 80 percent of the minimum nozzle waterway dimension.

**10.5.1.7 Demineralized Water.** Systems that utilize nozzles with a minimum nozzle waterway dimension less than 51 µm shall be supplied with demineralized water.

## 10.5.2 Pumps.

**10.5.2.1** Pumps supplying water mist systems shall be automatically controlled.

**10.5.2.2** Electrical or diesel-driven pumps supplying water mist systems shall be of sufficient capacity to exceed both the system flow rate and pressure demands as determined by hydraulic calculations, by a minimum of 10 percent for both flow and pressure. (See A.11.2.)

**10.5.2.3** The discharge piping for water mist pumps and pump assemblies for high pressure or intermediate pressure water mist systems shall be equipped with a valved test connection and provisions for the installation of a flow metering device to permit accurate measurement of the pump performance during the acceptance test and during annual testing.

**10.5.2.4 Supervision.** Pumps supplying water mist systems shall be supervised for the conditions specified in 10.5.2.4.1 and 10.5.2.4.2.

**10.5.2.4.1 Electric Pumps.** Supervisory conditions shall include the following:

- (1) Pump running
- (2) Loss of power
- (3) Phase reversal

**10.5.2.4.2 Diesel-Driven Pumps.** Supervisory conditions shall include the following:

- (1) Pump running
- (2) Power failure
- (3) Controller not in automatic position
- (4) Low oil pressure
- (5) High water temperature
- (6) Failure to start/overcrank
- (7) Overspeed
- (8) Fuel level (set at 75 percent capacity)

## 10.5.3 Tanks.

**10.5.3.1** Water tanks shall be arranged in accordance with NFPA 22, *Standard for Water Tanks for Private Fire Protection*.

**10.5.3.2** Water tanks shall be supervised for the following conditions:

- (1) Water level
- (2) Water temperature (for tanks located in unheated areas)
- (3) Air pressure (for pressure tanks)

## 10.5.4 Storage Containers.

**10.5.4.1** Storage containers and accessories shall be located and arranged to facilitate inspection, testing, recharging, and

other maintenance, while the interruption to protection shall be held to a minimum.

**10.5.4.2** Storage containers shall not be located where they are subject to severe weather conditions or to mechanical, chemical, or other damage.

**10.5.4.3** Where excessive climatic or mechanical exposures are expected, approved safeguards or enclosures shall be provided.

**10.5.4.4** Storage containers shall be installed and mounted (on the appropriate mounting surface) in accordance with the manufacturer's installation manual.

**10.5.4.5** Each pressurized container or cylinder shall be provided with a safety device to release excess pressure.

**10.5.4.6** A reliable means shall be provided to indicate the pressure and level in all storage containers that will be pressurized.

**10.5.4.7** A reliable means shall be provided to indicate the level in all storage containers that will not be pressurized.

## 10.5.5\* Fire Department Connection.

**10.5.5.1** A fire department connection shall be provided on the discharge side of the pressure source components.

**10.5.5.2** The connection to the system shall be made on the upstream (supply) side of the system strainer or filter for systems with operating pressures less than or equal to 12 bar (175 psi).

**10.5.5.3** The connection to the system shall be made on the suction side of the pressure source components for systems with operating pressures in excess of 12 bar (175 psi).

**10.5.5.4** The following systems shall not require a fire department connection:

- (1) Fire department connections shall not be required for systems protecting less than 200 m<sup>2</sup> (2000 ft<sup>2</sup>).
- (2) Fire department connections shall not be required for systems with operating pressures in excess of 12 bar (175 psi) and supplied only by storage cylinders.
- (3) Fire department connections shall not be required for systems where the atomizing medium is essential for fire suppression.

## 10.6 Atomizing Media for Twin-Fluid Systems.

**10.6.1 General.** Atomizing media essential to the production of water mist shall be taken from a dedicated source.

### 10.6.2 Plant Air.

**10.6.2.1** Plant air shall be permitted to be utilized as the atomizing media where the facility has an air supply that meets or exceeds the requirements of a dedicated main and reserve air supply, both meeting the quality, quantity, pressure, and reliability requirements of the listing and the approval of the authority having jurisdiction.

**10.6.2.2** Plant air used as an atomizing medium for a water mist system shall be monitored by the fire control panel, with the low air alarm set at a point at least 50 percent above the availability of two full system discharge requirements.

**10.6.3 Supervision.** Atomizing media shall be supervised for high and low pressure.

**10.6.4 Moisture Content.** Moisture content in the atomizing medium shall not exceed 25 ppm.

**10.6.5 Regulators.** Regulators controlling the supply of water for the atomizing medium shall be listed for the intended purpose.

**10.6.6 Check Valves.** A check valve or other means shall be installed in the piping at the supply point to prevent the entrance of water into the atomizing medium.

**10.6.7 Filters.** Filters or other means to protect nozzles from obstructions shall be provided in accordance with 10.5.1.4.

#### 10.6.8 Air Compressors.

**10.6.8.1** Air compressors used as a dedicated source shall be listed for use on fire protection systems.

**10.6.8.2** Compressors used as a dedicated supply shall be connected to a backup power supply.

**10.7 Pressure Gauges.** A pressure gauge shall be provided for each water supply and each atomizing medium.

## Chapter 11 Plans and Documentation

### 11.1 Working Plans.

**11.1.1 Submittal of Working Plans.** Working plans shall be submitted for approval to the authority having jurisdiction before any equipment is installed or remodeled.

**11.1.2 Deviations from Approved Plans.** Deviation from approved plans shall require permission of the authority having jurisdiction.

**11.1.3 Working Plans.** Working plans shall be drawn to specified scale on sheets of uniform size.

**11.1.4 Component Identification.** Special symbols shall be defined and used to identify clearly the components of the water mist system.

**11.1.5 Required Information.** The plans shall provide the following information that pertains to the design of the system:

- (1) Name of owner and occupant
- (2) Location, including street address
- (3) Point of compass and symbol legend
- (4) Location and construction of protected enclosure walls and partitions
- (5) Location of fire walls
- (6) Enclosure cross section, with full height or schematic diagram, including location and construction of building floor/ceiling assemblies above and below, raised access floor, and suspended ceiling
- (7) Description of occupancies and hazards being protected, designating whether the enclosure is normally occupied
- (8) Description of exposures surrounding the enclosure
- (9) Description of water and gas storage containers used, including make, internal volume, storage pressure, and nominal capacity expressed in units of mass or volume at standard conditions of temperature and pressure
- (10) Description of nozzles used, including manufacturer, size, orifice port configuration, and orifice size or part number
- (11) Description of pipe and fittings used, including material specifications, grade, and pressure rating
- (12) Description of wire or cable used, including classification, gauge (AWG), shielding, number of strands in con-

ductor, conductor material, and color coding schedule, with the segregation requirements of various system conductors clearly indicated and the required method of making wire terminations detailed

- (13) Description of the method of detector mounting
- (14) System equipment schedule or system bill of material indicating device name, manufacturer, model or part number, quantity, description, and documentation of approval or listing for the application
- (15) Plan view of the protected area, showing enclosure partitions (full and partial height); water distribution system, including storage containers or pumps; gas distribution system, including gas storage containers; piping; nozzles; type of pipe hangers and rigid pipe supports; detection, alarm, and control system, including all devices; end-of-line device locations; location of controlled/interlocked devices, such as dampers and shutters; and location of instructional signage
- (16) Isometric view of the water mist distribution system showing the length and diameter of each pipe segment; node reference numbers relating to the flow calculations; fittings, including reducers and strainers; orientation of tees; and nozzles, including size, orifice port configuration, and flow rate
- (17) Seismic building joints, if any, showing where water mist distribution or supply piping crosses the joint; expected movement of the seismic joint; details of the piping arrangement; and flexible connectors used to accommodate seismic movement
- (18) The calculation of seismic loads if seismic restraint is required by the authority having jurisdiction
- (19) Scale drawing showing the layout of the annunciator panel graphics if required by the authority having jurisdiction
- (20) Details of each unique rigid pipe support configuration showing method of securement to the pipe and to the structure
- (21) Details of the method of container securement showing method of securement to the container and to the structure
- (22) Complete step-by-step description of the system sequence of operations, including functioning of abort and maintenance switches, delay timers, and emergency power shutdown
- (23) Schematic diagrams and point-to-point wiring diagrams showing all circuit connections to the system control panels, detectors, system devices, controlled devices, external and add-on relays, and graphic annunciator panels
- (24) Schematic diagrams and point-to-point wiring diagrams of the system control panels
- (25) Complete calculations to determine enclosure volume for the application of water mist
- (26) Complete calculations to determine the size of backup batteries; the method used to determine the number and location of audible and visual indicating devices; and number and location of detectors

**11.1.6\* Symbols.** Symbols used on plans shall comply with NFPA 170, *Standard for Fire Safety and Emergency Symbols*, or ISO Standard 1219-1, *Fluid power systems and components — Graphic symbols and circuit diagrams — Part 1: Graphic symbols*, and ISO Standard 1219-2, *Fluid power systems and components — Graphic symbols and circuit diagrams — Part 2: Circuit diagrams*.



**11.2\* Hydraulic Calculation Documentation.**

**11.2.1 Hydraulic Calculation Sheets.** Unless the requirements of 11.2.2 are met, hydraulic calculations shall be prepared on form sheets that include a summary sheet, detailed work sheets, and a graph sheet.

**11.2.2 Pre-Engineered Systems.** The requirements of 11.2.1 shall not apply to pre-engineered systems.

**11.2.3 Summary Sheet.** The summary sheet shall contain the following information:

- (1) Date
- (2) Location
- (3) Name of owner and occupant
- (4) Building number or other identification
- (5) Description of hazard
- (6) Name and address of contractor or designer
- (7) Name of approving agency
- (8) System design requirements, including the following:
  - (a) Design area of water application or volume of space protected
  - (b) Minimum rate of water application (density)
  - (c) Area per nozzle
- (9) Total water requirements as calculated
- (10) Limitations (dimension, flow, and pressure) resulting from the use of automatic sprinkler systems or other water fire suppression systems

**11.2.4 Detailed Work Sheets.** The detailed work sheets or computer printouts shall contain the following information:

- (1) Sheet number
- (2) Nozzle description
- (3) Hydraulic reference points
- (4) Flow in L/min (gpm)
- (5) Pipe size
- (6) Pipe lengths, center to center of fittings
- (7) Equivalent pipe lengths for fittings and devices
- (8) Friction loss in bar/m (psi/ft) of pipe
- (9) Total friction loss between reference points
- (10) Elevation head in bar (psi) between reference points
- (11) Required pressure in bar (psi) at each reference point
- (12) Velocity pressure and normal pressure if included in calculations
- (13) System flushing locations
- (14) Notes to indicate starting points, reference other sheets, or clarify data shown
- (15) Diagram to accompany gridded system calculations to indicate flow quantities and directions for lines with water mist nozzles operating in the remote area
- (16) Other calculations necessary for design of the water mist system

**11.2.5 Graph Sheet.** A graphic representation of the complete hydraulic calculation shall be plotted on semilogarithmic ( $Q^{1.85}$ ) graph paper and shall include the following:

- (1) Water supply curve
- (2) Water mist system demand

**11.3 Pneumatic Calculation Documentation.**

**11.3.1 Pneumatic Calculation Sheets.** Unless the requirements of 11.3.2 are met, pneumatic calculations shall be prepared on form sheets that include a summary sheet and detailed work sheets.

**11.3.2 Pre-Engineered Systems.** The requirements of 11.3.1 shall not apply to pre-engineered systems.

**11.3.3 Summary Sheet.** The summary sheet shall contain the following information:

- (1) Date
- (2) Location
- (3) Name of owner and occupant
- (4) Building number or other identification
- (5) Description of hazard
- (6) Name and address of contractor or designer
- (7) Total gas volume required

**11.3.4 Detailed Work Sheets for Pneumatic Calculations.** The detailed work sheets or computer printouts shall contain the following information:

- (1) Sheet number
- (2) Nozzle description
- (3) Pneumatic reference points
- (4) Atomizing media flow rate [in L/min (in scfm)] and pressure at each nozzle
- (5) Air pressure to water pressure ratio at each nozzle
- (6) Pipe size
- (7) Pipe lengths
- (8) Total pressure loss between reference points
- (9) Required pressure in bar (psi) at each reference point
- (10) Notes to indicate starting points, reference other sheets, or clarify data shown

**11.4 Detection, Actuation, and Control Systems Documentation.**

**11.4.1 General.** After successful completion of acceptance tests satisfactory to the authority having jurisdiction, as-built installation documentation shall be prepared and provided to the system owner or the owner's designated representative, including as-built installation drawings, operation and maintenance manuals, a written sequence of operation, and reports.

**11.4.2 As-Built Installation Drawings.** A set of as-built installation drawings, reproducible and drawn to a scale specified on sheets of uniform size, shall provide the as-built configuration of detection, actuation, and control systems and shall include the following:

- (1) Name of owner and occupant
- (2) Location, including street address
- (3) Plan view of the protected area showing all detector locations; end-of-line device locations; location of detector indicating lights if separate from the detectors; location of audible and visual indicating devices; location of control panels; location of manual release and abort switches; location of controlled/interlocked devices such as dampers and shutters; location of maintenance and emergency power shutdown switches; and location of the annunciator panel
- (4) Equipment schedule or bill of materials for each piece of equipment or device indicating the device name, manufacturer, model or part number, quantity, and description
- (5) Description of wire or cable used, including classification, gauge (AWG), shielding, number of strands in conductor, conductor material, and color coding schedule, with the segregation requirements of various system conductors clearly indicated and the as-built method of making wire terminations detailed



- (6) Scale drawing showing the graphics layout of all annunciator panels
- (7) Schematic diagrams and point-to-point wiring diagrams showing all circuit connections to the system control panels, detectors, system devices, controlled devices, external and add-on relays, and graphic annunciator panels
- (8) Schematic diagrams and point-to-point wiring diagrams of the system control panels
- (9) Size and type of backup batteries
- (10) Details of any special features

#### 11.4.3 Documentation.

**11.4.3.1** Design, installation, operation, and maintenance manuals shall be provided to the user.

**11.4.3.2** Design and installation manuals shall provide information to allow the user or a third party to verify that the system has been designed and installed properly.

**11.4.3.3** Operation and maintenance manuals shall include operation and maintenance instructions for each piece of equipment or device of the as-built system.

**11.4.4 System Design Information Sign.** The installing contractor shall provide a permanently marked weatherproof metal or rigid plastic system design information sign secured with corrosion-resistant wire, chain, or other approved means. Such signs shall be placed at the control valve or equipment skid supplying the corresponding design area. The sign shall include the following information as applicable:

- (1) Location of the design area or areas
- (2) Design area of water application or volume of space protected
- (3) Nozzle manufacturer and model number
- (4) Area per nozzle
- (5) Total number of nozzles in design area
- (6) Minimum rate of water application (density)
- (7) Total water requirement as calculated
- (8) (If applicable) Total gas volume required
- (9) Description of the hazard protected
- (10) Description of any compartment or enclosure characteristics that are essential to system performance
- (11) Name of installing contractor and contact information

#### 11.4.5 Written Sequence of Operation.

**11.4.5.1** The written sequence of operation of the as-built system shall include a complete step-by-step description of the functioning of abort and maintenance switches, delay timers, and emergency power shutdown features.

**11.4.5.2** A logic diagram shall be provided.

**11.4.6 Reports.** Reports shall include inspection, testing, and maintenance reports.

## Chapter 12 System Acceptance

### 12.1 Approval of Water Mist Systems.

**12.1.1** A complete step-by-step description of the proposed acceptance test procedure, identifying all devices controls and functions to be tested and how the test will be conducted shall be approved prior to scheduling of acceptance testing.

**12.1.2** The completed system shall be reviewed and tested by qualified personnel to meet the approval of the authority having jurisdiction.

**12.1.3** These personnel shall confirm that listed equipment and devices have been used in the system where required by this standard.

**12.1.4** To determine that the system has been properly installed and functions as specified, the installing contractor shall take the following actions:

- (1) Notify the authority having jurisdiction and the owner's representative of the time and date testing is to be performed.
- (2) Perform all required acceptance tests.
- (3) Confirm in writing the status of all system components and controls.
- (4) When the system has not been left in service, confirm in writing those responsible for placing the system in service.

### 12.2\* Acceptance Requirements.

#### 12.2.1 Flushing or Cleaning of Piping.

##### 12.2.1.1 Water Supply Connection.

**12.2.1.1.1** Where systems are connected to municipal or private water supplies, underground mains and lead-in connections to water mist system piping shall be flushed completely before connection is made to water mist piping.

**12.2.1.1.2** The flushing operation shall be continued for a sufficient time to ensure thorough cleaning.

**12.2.1.1.3** The minimum rate of flow shall be one of the following, whichever is greater:

- (1) The hydraulically calculated water demand rate of the system
- (2) The maximum flow rate available to the system under fire conditions

##### 12.2.1.2 System Pipe or Tube.

**12.2.1.2.1** Each pipe or tube section shall be cleaned internally after preparation and before assembly in accordance with the manufacturer's installation manual.

**12.2.1.2.2** The piping network shall be free of particulate matter and oil residue before installation of nozzles or discharge devices.

#### 12.2.2 Hydrostatic Tests.

##### 12.2.2.1 General.

**12.2.2.1.1** The test pressure shall be read from a gauge located at the low elevation point of the system or portion being tested.

**12.2.2.1.2** Water used for testing shall be filtered or strained in accordance with 10.5.1.1, 10.5.1.2, and 10.5.1.3.

**12.2.2.1.3** Additives, corrosive chemicals such as sodium silicate, or derivatives of sodium silicate, brine, or other chemicals shall not be used while hydrostatically testing systems or for stopping leaks.

##### 12.2.2.1.4 Test Blanks.

**12.2.2.1.4.1** Test blanks shall have painted lugs protruding in such a way as to clearly indicate their presence.

**12.2.2.1.4.2** The test blanks shall be numbered, and the installing contractor shall have a record keeping method to ensure the removal of the test blanks after work is completed.

#### **12.2.2.2 Low Pressure System.**

**12.2.2.2.1** All interior piping and attached appurtenances subjected to a system working pressure less than or equal to 10.4 bar (150 psi) shall be hydrostatically tested at 13.8 bar (200 psi) and shall maintain that pressure without loss for 2 hours as determined by a drop in gauge pressure or visible leakage.

**12.2.2.2.2** Portions of systems or systems subjected to working pressures in excess of 10.4 bar (150 psi) shall be tested as described in 12.2.2.2.1 at a pressure of 3.5 bar (50 psi) in excess of the working pressure.

**12.2.2.2.3** Where cold weather does not allow testing with water, an interim air test shall be conducted as described in 12.2.3.

#### **12.2.2.3\* Intermediate and High Pressure Systems.**

**12.2.2.3.1** Intermediate and high pressure systems shall be permitted to be hydrostatically tested to 1.5 times the working pressure for 10 minutes, followed by 110 minutes at the working pressure without pressure loss in conformance with the ASME B31.1, *Power Piping Code*.

**12.2.2.3.2** A drop in pressure or visible leakage shall indicate pressure loss.

#### **12.2.3\* Air Tests.**

**12.2.3.1** For dry and preaction systems, an air pressure leakage test at 2.8 bar (40 psi) shall be conducted for 24 hours in addition to the standard hydrostatic test.

**12.2.3.2** Any leakage that results in a loss of pressure in excess of 0.1 bar (1.5 psi) during the 24 hours shall be corrected.

#### **12.2.4 Review of Components.**

##### **12.2.4.1 Review of Mechanical Components.**

**12.2.4.1.1** The piping system shall be inspected to determine that it is in compliance with the design and installation documents and hydraulic calculations.

**12.2.4.1.2** Nozzles and pipe size shall be in accordance with system drawings.

**12.2.4.1.3** The means of pipe size reduction and the attitudes of tees shall be checked for conformance to the design.

**12.2.4.1.4** Piping joints, discharge nozzles, and piping supports shall be restrained to prevent unacceptable vertical or lateral movement during discharge.

**12.2.4.1.5** Discharge nozzles shall be installed in such a manner that piping cannot become detached during discharge.

**12.2.4.1.6** The discharge nozzle shall be oriented in such a manner that optimum water mist application can be effected.

**12.2.4.1.7** The discharge nozzles, piping, and mounting brackets shall be installed in such a manner that they do not cause injury to personnel.

**12.2.4.1.8** All water and gas storage containers shall be located in accordance with an approved set of system drawings.

**12.2.4.1.9** All containers and mounting brackets shall be fastened in accordance with the manufacturer's requirements.

#### **12.2.4.2 Review of Electrical Components.**

**12.2.4.2.1** All wiring systems shall be checked for proper installation in conduit and in compliance with the approved drawings.

**12.2.4.2.2** It shall be confirmed that ac wiring and dc wiring are not combined in a common conduit or raceway unless properly shielded and grounded.

**12.2.4.2.3** All field circuits shall be confirmed to be free of ground faults and short circuits.

**12.2.4.2.4** Where measuring field circuitry, the following shall apply:

- (1) All electronic components, such as smoke and flame detectors or special electronic equipment for other detectors or their mounting bases, shall be removed.
- (2) Jumpers shall be installed properly to prevent the possibility of damage within these devices.
- (3) All components shall be replaced after measuring.

**12.2.4.2.5** The detection devices shall be checked for proper type and location as specified on the system drawings.

**12.2.4.2.6** The detectors shall be installed in a professional manner and in accordance with technical data regarding their installation and the following, as applicable:

- (1) *NFPA 72, National Fire Alarm and Signaling Code*, shall be referenced for installation requirements.
- (2) In Canada, *CAN/ULC S524-06, Standard for the Installation of Fire Alarm Systems*, and *CAN/ULC S529-02, Standard for Smoke Detectors for Fire Alarm Systems*, shall be referenced.

**12.2.4.2.7** Manual pull stations shall be confirmed as accessible, accurately identified, and properly protected to prevent damage.

##### **12.2.4.2.8 Abort Switches.**

**12.2.4.2.8.1** For systems using abort switches, the switches shall be confirmed to be of the deadman type that necessitates constant manual pressure, properly installed, accessible within the hazard area, and clearly identified.

**12.2.4.2.8.2** Switches that remain in the abort position when released shall not be permitted for this purpose.

**12.2.4.2.8.3** Verification that normal and manual emergency control overrides the abort function shall be made.

**12.2.4.2.9** Polarity shall have been observed on all polarized alarm devices and auxiliary relays.

**12.2.4.2.10** All end-of-line resistors shall have been installed across the detection and alarm bell circuits where required.

**12.2.4.2.11** The control unit shall be checked for proper installation and accessibility.

**12.2.4.2.12\*** All wiring systems shall be checked for proper grounding and shielding.

**12.2.4.2.13** It shall be verified that the water mist system branch piping has not been used as an electrical ground.

#### **12.2.5 Preliminary Functional Tests.**

##### **12.2.5.1 Alarm Receiving Office.**

**12.2.5.1.1** If the system is connected to an alarm receiving office, the alarm receiving office shall be notified that the fire system test is to be conducted and that an emergency response by the fire department is not desired.

**12.2.5.1.2** All concerned personnel at the end user's facility shall be notified that a test is to be conducted and shall be instructed as to the sequence of operation.

**12.2.5.2 Release Mechanisms.**

**12.2.5.2.1** Each water mist release mechanism shall be disabled so that activation of the release circuit does not release water mist.

**12.2.5.2.2** The release circuit shall be reconnected with a functional device in lieu of each water mist release mechanism in accordance with the following:

- (1) For electrically actuated release mechanisms, these devices shall be permitted to include 24 volt lamps, flash bulbs, or circuit breakers.
- (2) For pneumatically actuated release mechanisms, these devices shall be permitted to include pressure gauges.

**12.2.5.2.3** The manufacturer's installation manual shall be referenced for recommended procedures and test methods.

**12.2.5.3 Detector Testing.** Each detector shall be checked for proper response.

**12.2.5.4 Auxiliary Functions.** All auxiliary functions such as alarm sounding or displaying devices, remote annunciators, air-handling shutdown, and power shutdown shall be checked for intended operation in accordance with system requirements and design specifications.

**12.2.5.5 Manual Pull Stations.** Manual pull stations shall be checked to confirm that they override abort switches.

**12.2.5.6 Supervised Circuits.** All supervised circuits shall be checked for proper trouble response.

**12.2.5.7 Cross-Zoned Detection Systems.** For systems where the detection system is cross-zoned, two detectors (one each zone) should be activated sequentially to verify that the release circuit performs in accordance with design specifications.

**12.2.6 System Operational Tests.**

**12.2.6.1** Unless the requirements of 12.2.6.2 are met, full-flow tests of the system piping using water shall be made as a means of checking the nozzle layout, discharge pattern, and any obstructions; determining the relationship between design criteria and actual performance; and ensuring against the clogging of the smaller piping and nozzles by foreign matter carried by the water.

**12.2.6.2** The requirements of 12.2.6.1 shall not apply where a full flow test using water is not possible, in which case the connection to the water supply shall be permitted to be verified by flowing water from each test connection.

**12.2.6.3** Where practicable, the maximum number of systems that are expected to operate in case of fire shall be in full operation simultaneously when the adequacy and condition of the water supply are checked.

**12.2.6.4** All operating parts of the system shall be tested fully to ensure that they function as intended.

**12.2.6.5** It shall be verified that all devices function properly and that they are properly sequenced.

**12.2.6.6** After flow testing, all filters and strainers shall be inspected, and cleaned or replaced, as necessary.

**12.2.7 System Design Information Sign.** The accepting authority shall confirm that the system design information sign has been provided and that it accurately reflects the system design parameters.

## Chapter 13 System Maintenance

### 13.1 Responsibility of the Owner or Occupant.

#### 13.1.1 General.

**13.1.1.1** The responsibility for properly maintaining a water mist fire protection system shall be the obligation of the property owner.

**13.1.1.2** By means of periodic inspection, tests, and maintenance, in accordance with the standard and manufacturers' requirements, either this equipment shall be shown to be in good operating condition or that defects or impairments exist.

**13.1.1.3** Inspection, testing, and maintenance activities shall be implemented in accordance with procedures meeting or exceeding those established in this document and in accordance with the manufacturer's instructions.

**13.1.1.4** These tasks shall be performed by personnel who have developed competence through training and experience.

#### 13.1.2 Notification.

**13.1.2.1** The owner or occupant shall notify the authority having jurisdiction, the fire department (if required), and the alarm receiving facility before shutting down a system or its supply.

**13.1.2.2** The notification shall include the purpose of the shutdown, the system or component involved, and the estimated time needed.

**13.1.2.3** The authority having jurisdiction, the fire department, and the alarm receiving facility shall be notified when the system, supply, or component is returned to service.

#### 13.1.3 Correction or Repair.

**13.1.3.1** The owner or occupant shall promptly correct or repair deficiencies, damaged parts, or impairments found while performing the inspection, test, and maintenance requirements of this standard.

**13.1.3.2** Corrections and repairs shall be performed by qualified maintenance personnel or a qualified contractor.

#### 13.1.4 System Re-evaluation.

**13.1.4.1** The owner or occupant shall give special attention to factors that might alter the requirements for a continued approved installation.

**13.1.4.2** Such factors shall include, but shall not be limited to, the following:

- (1) Occupancy changes
- (2) Process or material changes
- (3) Structural revisions such as relocated walls, added horizontal or vertical obstructions, or ventilation changes
- (4) Removal of heating systems in spaces with piping subject to freezing

#### 13.1.5 Changes of Occupancy.

**13.1.5.1** Where changes in the occupancy, hazard, water supply, storage arrangement, structural modification, or other conditions that affect the installation criteria of the system are identified, the owner or occupant shall promptly take steps to evaluate the adequacy of the installed system to protect the hazard in question, such as contacting a qualified contractor, consultant, or engineer.

**13.1.5.2** Where the evaluation reveals a deficiency, the owner shall notify the insurance underwriter, the authority having jurisdiction, and the local fire department.

### 13.1.6 Return to Service.

**13.1.6.1** Where a water mist system is returned to service following an impairment, it shall be verified that it is working properly.

**13.1.6.2** Chapter 12 shall be referenced to provide guidance on the type of inspection or test, or both, that is required.

## 13.2 Inspection and Testing.

### 13.2.1 Components and Systems.

**13.2.1.1** All components and systems shall be inspected and tested to verify that they function as intended.

**13.2.1.2** Water mist systems that are equipped with an additive system shall be tested with the specific additive system engaged or used during the acceptance testing.

**13.2.2\* Frequencies.** The frequency of inspections of components of water mist systems shall be in conformance with the manufacturer's listing requirement and NFPA 25, *Standard for the Inspection, Testing, and Maintenance of Water-Based Fire Protection Systems*.

**13.2.3\* Restoration.** Following tests of components or portions of water mist systems that require valves to be opened or closed, the system shall be returned to service, with verification that all valves are restored to their normal operating position, that the water has been drained from all low points, that screens and filters have been checked and cleaned, and that plugs or caps for auxiliary drains or test valves have been replaced.

**13.2.4 Specialized Equipment.** Specialized equipment required for testing shall be in accordance with the manufacturer's specifications.

**13.2.5 High Pressure Cylinders.** High pressure cylinders used in water mist systems shall not be recharged without a hydrostatic test (and remarking) if more than 5 years have elapsed from the date of the last test. Cylinders that have been in continuous service without discharging shall be permitted to be retained in service for a maximum of 12 years, after which they shall be discharged and retested before being returned to service.

### 13.3 Maintenance.

**13.3.1** Maintenance shall be performed to keep the system equipment operable or to make repairs.

**13.3.2** As-built system installation drawings, original acceptance test records, and device manufacturer's maintenance bulletins shall be retained to assist in the proper care of the system and its components.

**13.3.3** Preventive maintenance includes, but is not limited to, lubricating control valve stems, adjusting packing glands on valves and pumps, bleeding moisture and condensation from air compressors and air lines, and cleaning strainers.

**13.3.4** Scheduled maintenance shall be performed as outlined in Table 13.3.4.

**13.3.5** Corrective maintenance includes, but is not limited to, replacing loaded, corroded, or painted nozzles, replacing missing or loose pipe hangers, cleaning clogged fire pumps,

**Table 13.3.4 Maintenance Frequencies**

| Item                  | Activity                     | Frequency              |
|-----------------------|------------------------------|------------------------|
| Water tank            | Drain and refill             | Annually               |
| System                | Flushing                     | Annually               |
| Strainers and filters | Clean or replace as required | After system operation |

replacing valve seats and gaskets, and restoring heat in areas subject to freezing temperatures where water-filled piping is installed.

**13.3.6** Emergency maintenance includes, but is not limited to, repairs due to piping failures caused by freezing or impact damage, repairs to broken water mains, and replacing frozen or fused nozzles, defective electric power, or alarm and detection system wiring.

**13.3.7** Specific maintenance activities, where applicable to the type of water mist system, shall be performed in accordance with the schedules in Table 13.3.4.

**13.3.8** Replacement components shall be in accordance with the manufacturer's specifications and the original system design.

**13.3.9** Spare components shall be accessible and shall be stored in a manner to prevent damage or contamination.

**13.3.10\*** After each system operation, a representative sample of operated water mist nozzles in the activated zone shall be inspected.

**13.3.11** After each system operation due to fire, the system filters and strainers shall be cleaned or replaced.

### 13.4 Training.

**13.4.1** All persons who might be expected to inspect, test, maintain, or operate water mist systems shall be trained thoroughly in the functions they are expected to perform.

**13.4.2** Refresher training shall be provided as recommended by the manufacturer or by the authority having jurisdiction.

## Chapter 14 Marine Systems

**14.1 General.** This chapter outlines the deletions, modifications, and additions that shall be required for marine applications; all other requirements of this standard shall apply to merchant vessel systems except as modified by this chapter.

**14.1.1 Marine Definitions.** The following definitions shall be applicable to this chapter.

**14.1.1.1 Sprinkler Equivalent Systems.** Systems protecting spaces where the predominant hazard consists of Class A combustibles. Examples include accommodation spaces, public spaces, galleys, and storerooms.

**14.1.1.2 Flammable Liquid Hazard Systems.** Systems protecting spaces where the predominant hazard consists of flammable and combustible liquids. Examples include machinery spaces, flammable liquid storerooms, cargo pump rooms, and paint lockers.

**14.1.2\* Efficacy and Reliability.**

**14.1.2.1** Sprinkler equivalent systems shall comply with the fire suppression and component manufacturing tests of IMO Assembly Resolution A.800(19).

**14.1.2.2** Flammable liquid hazard systems shall comply with fire suppression and components manufacturing tests contained in IMO MSC/Circ. 668, *Alternative Arrangements for Halon Fire-Extinguishing Systems in Machinery Spaces and Pumprooms*, as amended by IMO MSC/Circ. 728, *Revised Test Method for Equivalent Water-Based Fire-Extinguishing Systems for Machinery Spaces of Category A and Cargo Pump-Rooms Contained in MSC/Circ. 668*.

**14.1.3 Listing and Approval.**

**14.1.3.1** All marine water mist systems and their components shall be listed or approved.

**14.1.3.2** Piping and fittings shall be in accordance with Table 5.3.3.1 and Table 5.4.2.1.

**14.1.4 General Design.** The system and equipment shall be suitably designed to withstand all of the following as normally encountered in ships:

- (1) Ambient temperature changes
- (2) Vibrations
- (3) Humidity
- (4) Shock
- (5) Impact
- (6) Clogging
- (7) Corrosion

**14.1.5\* Mounting and Hanging.** Equipment and piping system mounting and hanging shall be in accordance with internationally recognized standards for marine applications.

**14.1.6\* Pump Redundancy.** The required water mist pumps shall be arranged such that with the largest pump out of service, the greatest system demand can still be satisfied.

**14.1.7 Controls and Alarms.**

**14.1.7.1** Pump systems shall have all of the following:

- (1) Automatic pump start-up
- (2) Manual pump start and annunciation at the following locations:
  - (a) Within sight of the pump
  - (b) Engine control room
  - (c) Central control station where provided

**14.1.7.2** Annunciation shall include the following (as applicable):

- (1) Power available/power failure
- (2) Waterflow and location
- (3) Pump run
- (4) Diesel driver oil pressure

**14.1.7.3** Any flow condition shall sound an alarm on the bridge or at a constantly manned control station.

**14.1.7.4** On the bridge and in the engine control room, there shall be a pressure monitor consisting of one of the following:

- (1) Pressure gauge
- (2) Transducer system
- (3) High/low/OK pressure switch

**14.1.8\* Pipe Penetrations.** Pipe penetrations through bulkheads and decks shall be in accordance with U.S. Coast Guard

Navigation and Vessel Inspection Circular (NVIC) 9-97, *Guide to Structural Fire Protection*.

**14.1.9 Shore Connection.**

**14.1.9.1** Shore connection shall be provided in accordance with 10.5.5.

**14.1.9.2** At least one shore connection shall be located on the main deck in an area likely to be visible to shore responders.

**14.1.9.3 Shore Connection Manifold.**

**14.1.9.3.1** The shore connection shall consist of both a 63.5 mm (2½ in.) diameter NST siamese with a check valve and an international shore connection with a check valve.

**14.1.9.3.2** Each shore connection manifold shall have a drain to prevent freezing.

**14.1.9.3.3** Check valves shall be provided and arranged such that standing water is not closer than 1.24 m (4 ft) from the through-bulkhead penetration where the piping becomes exposed to freezing weather.

**14.1.9.4\* Shore Connection Identification.**

**14.1.9.4.1** The shore connection shall be painted red or fitted with red bands.

**14.1.9.4.2** The shore connection shall be fitted with a permanent, engraved sign identifying it as the sprinkler system shore connection.

**14.1.9.4.3** The sign shall specify the recommended pressure to be maintained by shore responders or fire-fighting vessels at the connection.

**14.1.9.4.4** The lettering of the sign shall be a minimum of 25.4 mm (1 in.) high block letters.

**14.1.10\* Pump Test Connection.** Each system served by one or more dedicated pumps shall be provided with a means for measuring the discharge flow rate and pressure from each pump.

**14.1.11 Piping.** Piping between a vessel's sea chest and the first shutoff valve shall be Schedule 80 steel or Schedule 40 galvanized steel in accordance with 46 CFR 56.50-95(3).

**14.1.12 Copper Pipe.**

**14.1.12.1** Copper pipe shall be routed to avoid mechanical damage, especially situations that could cause the piping to become pinched.

**14.1.12.2** Copper pipe shall not be located in cargo holds.

**14.1.12.3** Copper pipe on vehicle decks shall be protected against damage from moving vehicles.

**14.1.12.4 Galvanic Corrosion.**

**14.1.12.4.1** The prevention of galvanic corrosion shall be considered by the system designer.

**14.1.12.4.2** In areas where the exterior of the pipe is regularly subject to extreme humidity, moisture, or spray, pipe hangers shall be resistant to galvanic corrosion.

**14.1.12.4.3** Dielectric pipe hanger insulators, such as nonmetallic bands between the hangers and the pipe wall, or stainless steel hangers shall be used.

**14.1.12.5** Copper pipe shall conform to ASTM B 88, *Standard Specification for Seamless Copper Water Tube*, Types M, L, or K, or ASTM B 42, *Standard Specification for Seamless Copper Pipe, Standard Sizes*.

**14.1.12.6** Connections of joints and fittings shall be resistant to mechanical damage and degradation when exposed to fire conditions.

**14.1.12.7** Joints and connections in ASTM B 88 tubing shall be brazed.

**14.1.12.8** Fittings in ASTM B 42 tubing shall be permitted to be brazed, threaded, or joined using a mechanical connector listed for the intended purpose.

**14.1.12.9** Filler materials in joints in copper pipe shall not melt at a temperature below 927°C (1700°F).

**14.1.12.10** Brazed joints using filler materials with melting points below 927°C (1700°F) shall be permitted in systems that comply with all of the following:

- (1) Brazed joints shall be made in accordance with 46 CFR 56.75 using a filler material having a melting temperature above 538°C (1000°F).
- (2) All shutoff valves upstream of, or within, copper piping having brazed joints shall be electrically supervised with an audible and visual signal at a control station.
- (3) Each shutoff valve shall be located within an enclosed stair or outside the protected zone.
- (4) The system shall be wet pipe automatic.
- (5) Brazed joints shall not be located in machinery spaces, spaces containing pressurized oil lines, areas subject to flammable liquid or gas fires, or other areas having high fire risks.
- (6) Each section capable of being isolated shall be fitted with a relief valve set at the maximum working pressure of the system.

#### 14.1.13 Strainers and Filters.

**14.1.13.1** Strainers and filters shall be provided and sized for the worst-case water quality conditions expected.

**14.1.13.2** The filters shall be located on the inlet side of the pump and shall permit the operation of the system at the required flow rate and minimum pressure for at least 120 minutes.

#### 14.2 Sprinkler Equivalent Systems.

**14.2.1** The system shall be automatic.

**14.2.2\*** A pressure tank system shall be provided to meet the functional requirements for Safety of Life at Sea (SOLAS) Regulation II-2/12.4.1.

**14.2.3\*** Systems shall be arranged with an automatic supply of fresh water capable of supporting the entire design area for 30 minutes and shall be permitted to allow manual intervention for continued operation after the 30-minute water supply is exhausted.

**14.2.4** Manual intervention shall be limited to the actions of opening valves and starting or engaging pumps.

**14.2.5** The system shall be fitted with a permanent sea inlet and shall be capable of continuous operation using seawater for a period of at least 120 minutes.

**14.2.6** Strainers and filters shall be provided and sized for the worst-case water quality conditions expected.

**14.2.7\*** Unless the requirements of 14.2.8 are met, the system shall be of the wet pipe type.

**14.2.8** The requirements of 14.2.7 shall not apply where environmental conditions dictate; small sections shall be permitted to be of another approved type.

**14.2.9** The system shall be provided with main and emergency sources of power.

**14.2.10** Pumps and alternate supply components shall be sized to be capable of maintaining the required flow.

#### 14.2.11 Design.

**14.2.11.1** The system's water supply and the system piping shall be capable of maintaining the minimum required operating pressure for each type of nozzle at the highest elevation of each type of nozzle.

**14.2.11.2** Hydraulic sizing calculations shall be based on the hydraulically most demanding 140 m<sup>2</sup> (1500 ft<sup>2</sup>) deck area of nozzle operation occurring concurrently within each of any two main vertical fire zones.

**14.2.11.3** Reference shall be made to the marine regulatory authority having jurisdiction for guidance on the hydraulic sizing of the system's water supply and piping for small ships with a total protected deck area of less than 140 m<sup>2</sup> (1500 ft<sup>2</sup>).

**14.2.11.4** For ordinary hazard spaces, the design area shall be the deck area of the most hydraulically demanding compartment up to a maximum of 280 m<sup>2</sup> (3000 ft<sup>2</sup>).

**14.2.11.5** For light hazard public and accommodation spaces, the design area shall be the deck area of the most hydraulically demanding compartment up to a maximum of 140 m<sup>2</sup> (1500 ft<sup>2</sup>).

**14.2.11.6 Room Design.** The water supply requirements for nozzles only shall be based on the room that creates the greatest demand in accordance with the following:

- (1) The density selected shall be in accordance with the listing.
- (2) All rooms shall be enclosed with walls having a fire resistance rating of A-15 or B-15.

**14.2.11.7 Minimum Protection of Openings.** The minimum protection of openings shall be as follows:

- (1) *Light hazard*
  - (a) Automatic or self-closing doors with appropriate fire resistance ratings for the enclosure.
  - (b) Where opening is not protected, calculations shall include the nozzle in the room plus two nozzles in the communication space nearest each such unprotected opening, unless the communication space has only one nozzle, in which case calculations shall be extended to the operation of that nozzle, where the selection of the room and communication space nozzles to be calculated shall be that which produces the greatest hydraulic demand.
- (2) *Ordinary and extra hazard.* Automatic or self-closing doors having fire resistance ratings for the enclosure.

**14.2.12** Spaces shall be permitted to be protected with alternative, approved fire suppression systems where such areas are separated from mist-protected areas with a 1-hour rated assembly.

#### 14.2.13 Location.

**14.2.13.1** Water mist supply components shall be located outside Category A machinery spaces.

**14.2.13.2** This location shall apply to pumps, pressure tanks, cylinder tanks, emergency power cables, and controllers.

**14.2.14\*** Unless the requirements of 14.2.13 are met, concealed spaces that are constructed of combustible materials or materials with combustible finishes or contain combustible materials shall be protected by the system.

**14.2.15** The requirements of 14.2.12 shall not apply to concealed spaces protected by automatic sprinklers installed in accordance with NFPA 13, *Standard for the Installation of Sprinkler Systems*, or other listed or approved automatic fire suppression system.

### 14.3 Flammable Liquids — Total Area Protection.

#### 14.3.1 General.

**14.3.1.1** Unless the requirements of 14.3.1.2 are met, Section 14.3 shall apply to systems protecting spaces where the predominant hazard is from flammable liquids.

**14.3.1.2** The requirements of 14.3.3.1, 14.3.4, 14.3.5.3, 14.3.5.4, 14.3.5.7, and 14.3.6 shall not apply to systems protecting paint lockers having containers not larger than a 50 L (13 gal) individual capacity.

**14.3.2 Spaces.** Flammable liquid hazard systems shall be shown by test to be capable of extinguishing a variety of fires that can occur in spaces where the predominant hazard consists of flammable liquids.

**14.3.2.1\*** Systems for machinery spaces and cargo pump rooms shall be capable of fire extinguishment as demonstrated by testing in accordance with the IMO *Code for Application of Fire Test Procedures*.

**14.3.2.2** Systems for flammable liquid storerooms, paint lockers, and other flammable liquid hazards shall be based on tests acceptable to the authority having jurisdiction.

**14.3.2.3** Nozzle locations, types of nozzles, and spray characteristics shall be within the limits tested.

#### 14.3.3\* Manual Actuation.

**14.3.3.1** The system shall be capable of manual actuation, allowing water to discharge into the protected space without the necessity of further human intervention.

**14.3.3.2\*** After 30 minutes of system activation, manual intervention shall be permitted for continued operation.

**14.3.4\* Time Delay and Signals.** Where time delays are provided, audible and visual signals shall be provided throughout the protected space.

#### 14.3.5 Water Supply.

**14.3.5.1** The system's water supply shall be available for immediate use.

**14.3.5.2** The water supply shall be based on complete protection of the space demanding the greatest quantity of water.

**14.3.5.3** Pressure tank(s) shall be provided to immediately supply the system at the design flow and pressure for not less than 60 seconds.

#### 14.3.5.4 Freshwater Supply.

**14.3.5.4.1** The water supply shall supply the system with freshwater for a period of at least 30 minutes. The vessel's potable water supply shall be permitted to satisfy the 30-minute demand period.

**14.3.5.4.2** The freshwater supply shall meet the water quality requirements of 10.5.1.

**14.3.5.5** Where the water mist system is designed for uniform cycling, the maximum reduced discharge period shall be 60 seconds.

**14.3.5.6\* Water and Atomizing Media Quality.** The minimum quantity of water and atomizing media used in uniform cy-

cling systems shall be the maximum system flow for a 15-minute constant duration.

#### 14.3.5.7\* Sea Inlet.

**14.3.5.7.1** Unless the requirements of 14.3.5.7.5 are met, the system shall be fitted with a permanent sea inlet and shall be capable of continuous operation using seawater.

**14.3.5.7.2** The permanent sea inlet shall be constructed of corrosion-resistant materials as required by 5.1.3 and shall be fitted with a control valve and a strainer having maximum mesh openings of 6 mm (0.236 in.).

**14.3.5.7.3** The permanent sea inlet shall be located in the same space as the system pump.

**14.3.5.7.4** When the vessel is under way, it shall not be necessary to shut off the supply of seawater to the system pump for any purpose other than the inspection or repair of the system pump.

**14.3.5.7.5** The requirements of 14.3.5.7 shall not apply to systems protecting spaces smaller than 3000 m<sup>3</sup> where the system is listed without a sea inlet or where tests have been conducted to the satisfaction of the authority having jurisdiction.

#### 14.3.6\* Power Supplies.

**14.3.6.1** The system shall be provided with both main and emergency sources of power and shall be provided with automatic changeover.

**14.3.6.2** One of those sources of power shall be wholly provided from outside the protected space.

**14.3.7 Location of Pressure Source Components.** Pressure source components of the system shall be located outside the protected space.

**14.3.8 Operational Tests.** A means to allow for periodic testing of the operation of the system for ensuring the required pressure and flow shall be provided.

#### 14.3.9 Machinery Spaces on Towing Vessels and Other Uninspected Vessels.

**14.3.9.1** Systems for machinery spaces shall be capable of fire extinguishment without the necessity of engine shutdown, personnel evacuation, shutdown of forced ventilation fans, or the sealing of the space as demonstrated by fire testing in accordance with IMO MSC/Circ. 913, *Guidelines for the Approval of Fixed Water-Based Local Application Fire-Fighting Systems for Use in Category A Machinery Spaces*.

**14.3.9.2** Component testing shall be in accordance with the following provisions of Appendix A of IMO MSC/Circ. 728, *Revised Test Method for Equivalent Water-Based Fire-Extinguishing Systems for Machinery Spaces of Category A and Cargo Pump Rooms Contained in MSC/Circ. 668*.

- (1) MSC/Circ. 668, Section 3.4, "Water Flow and Distribution"
- (2) MSC/Circ. 668, Section 3.6, "Strength of Body"
- (3) MSC/Circ. 668, Section 3.11, "Corrosion"
- (4) MSC/Circ. 668, Section 3.15, "Resistance to Heat"
- (5) MSC/Circ. 668, Section 3.16, "Resistance to Vibration (Plus Functional Test in 3.5.2 Only)"
- (6) MSC/Circ. 668, Section 3.17, "Impact"
- (7) MSC/Circ. 668, Section 3.22, "Clogging"

**14.3.9.3** The water mist system shall be designed as a local application system that covers the entire engine room with a uniform grid of nozzles located within the tested spacing limitations.

**14.3.9.4** The distance from the nozzles to the plane of protection (generally, the top of the engine) shall be within the tested limits.

**14.3.9.5** Additional nozzles shall be installed to protect obstructed hazards, such as fuel lines and fittings, as specified by the manufacturer.

**14.3.9.6** The system shall be designed as an open-head, deluge-type system with manual release capability.

**14.3.9.7** Manual releases shall be located outside a main exit from the engine room, and at the engineering control booth if one is provided.

**14.3.9.8** The system shall be self-contained and shall require no additional source of power.

**14.3.9.9** The system water and gas storage cylinders and valves shall be located outside the engine room, or if inside the engine room, they shall be in a location shielded from direct fire exposure from below.

**14.3.9.10** The system nozzles, valves, and pressure vessels shall be listed.

**14.3.9.11** The system storage containers shall contain sufficient water to fill the system piping and provide at least 10 minutes of discharge.

**14.3.9.12** The system shall have a backup water supply from either a 38 mm (1½ in.) fire department connection located on the open deck or a connection to a fixed fire pump.

**14.4\* Human Factors.** Human factors shall be considered to the extent practicable in the design of water mist systems on marine vessels.

**14.5\* Requirements for Water Mist Systems on Combatant Vessels.**

**14.5.1** Combatant vessels require more stringent design requirements than merchant ships.

**14.5.2** Water mist system design features for combatant vessels shall be determined by the authority having jurisdiction of the military service involved.

## Annex A Explanatory Material

*Annex A is not a part of the requirements of this NFPA document but is included for informational purposes only. This annex contains explanatory material, numbered to correspond with the applicable text paragraphs.*

**A.1.1** Other NFPA standards should be referenced for additional requirements relating to underground or lead-in connections to water mist systems from municipal or private water supplies.

**A.1.2** Water mist systems are specialized fire protection systems. Design and installation of these systems necessitates specialized training, knowledge, and experience.

Water mist systems offer potential benefits for many specialized applications, particularly where available water supplies are limited or where the application of water needs to be restricted. Potential benefits also might exist for applications previously protected by gaseous and other fire suppressant agents.

**A.1.6** For additional conversions and information, see ASTM E 380, *Standard Practice for Use of the International System of Units*

(*SI*) (*the Modernized Metric System*), and in Canada, refer to CSA CAN3-A234.1, *Canadian Metric Practice Guide*.

The abbreviation “gal” in Table 1.6.3 indicates the U.S. gallon measure.

**A.3.2.1 Approved.** The National Fire Protection Association does not approve, inspect, or certify any installations, procedures, equipment, or materials; nor does it approve or evaluate testing laboratories. In determining the acceptability of installations, procedures, equipment, or materials, the authority having jurisdiction may base acceptance on compliance with NFPA or other appropriate standards. In the absence of such standards, said authority may require evidence of proper installation, procedure, or use. The authority having jurisdiction may also refer to the listings or labeling practices of an organization that is concerned with product evaluations and is thus in a position to determine compliance with appropriate standards for the current production of listed items.

**A.3.2.2 Authority Having Jurisdiction (AHJ).** The phrase “authority having jurisdiction,” or its acronym AHJ, is used in NFPA documents in a broad manner, since jurisdictions and approval agencies vary, as do their responsibilities. Where public safety is primary, the authority having jurisdiction may be a federal, state, local, or other regional department or individual such as a fire chief; fire marshal; chief of a fire prevention bureau, labor department, or health department; building official; electrical inspector; or others having statutory authority. For insurance purposes, an insurance inspection department, rating bureau, or other insurance company representative may be the authority having jurisdiction. In many circumstances, the property owner or his or her designated agent assumes the role of the authority having jurisdiction; at government installations, the commanding officer or departmental official may be the authority having jurisdiction.

**A.3.2.3 Listed.** The means for identifying listed equipment may vary for each organization concerned with product evaluation; some organizations do not recognize equipment as listed unless it is also labeled. The authority having jurisdiction should utilize the system employed by the listing organization to identify a listed product.

**A.3.3.1 Additive.** Additives used can be for any purpose such as enhanced fire performance, microbiologic growth inhibitors, corrosion inhibitors, freeze protection, and so forth. Chemical additives should be reviewed with the manufacturer for consideration of health or environmental issues, both positive and negative. The additive manufacturer should be consulted regarding additive availability; shelf life, whether in premix or concentrated form; specific compatibility with other chemicals; additive performance; and approvals for intended use.

**A.3.3.2 Additive Proportioning.** Additives can be proportioned by any acceptable method, including the following:

- (1) *Premix Solution.* Premixed additive solution mixed in a predetermined percentage of additive to water as recommended by the manufacturer. Care should be taken to ensure the water/additive solution will not corrode the solution pressure vessel.
- (2) *Metered Proportioning.* A separate additive pump is used to inject additives into the water stream. Orifices, venturis, or flowmeters control or measure the proportion of additive to water. Either manual or automatic adjustment of additive injection or flow control can be utilized.



- (3) *Balanced Pressure Proportioning.* A pump or diaphragm tank that contains additives is used in conjunction with a variable or fixed orifice to proportion the additive percentage in relation to the waterflow rate. As waterflow rates change, the variable orifice allows more or less additive to be pumped or injected into the water system.
- (4) *Proportioning System Accuracy.* Where automatic additive proportioning methods are used, the accuracy of the proportioning system should be acceptable to the authority having jurisdiction.

**A.3.3.4  $Dv_{0.50}$ .**  $Dv_{0.50}$  is the volume median diameter; that is, 50 percent of the total volume of liquid is in drops of smaller diameter and 50 percent is in drops of larger diameter.

**A.3.3.5 Enclosure.** Examples of enclosures include a room, building, vessel, silo, bin, pipe, and duct.

**A.3.3.14 Shall be Considered.** Such documentation should be retrievable and can be in the form of engineering studies, meeting minutes, reports, internal memoranda, and so forth.

**A.3.3.19 Water Mist.** This standard addresses the use of fine water sprays for the efficient control, suppression, or extinguishment of fires using limited volumes of water. Properly designed water mist systems can be effective on both liquid fuel (Class B) and solid fuel (Class A) fires. Research indicates that fine (i.e., smaller than 400 microns) droplets are essential for extinguishment of Class B fires, although larger drop sizes are effective for Class A combustibles, which benefit from extinguishment by fuel wetting. For this reason, the definition of water mist in this standard includes sprays with  $Dv_{0.99}$  of up to 1000  $\mu$ .

This standard's interpretation of "water mist" includes some water sprays used in NFPA 15, *Standard for Water Spray Fixed Systems for Fire Protection*, some sprays produced by standard sprinklers operating at high pressure, as well as light mists suitable for greenhouse misting and HVAC humidification systems. This range in drop size distribution is so broad that some important differences in the performance of sprays with finer different distributions are not distinguished.

The relationship between drop size distribution and extinguishing capacity of a water mist is complex. In general, very fine particles enhance heat absorption and generation of water vapor. With liquid (Class B) fuels, too many "large" drops could agitate the surface of the fuel and increase burning intensity. On the other hand, larger drops could assist the spray to penetrate and wet charred, smoldering Class A fuels. Larger drops could also entrain finer drops in their wake and improve the transport of much smaller drop sizes into the seat of the fire.

Drop size distribution alone does not determine the ability of a spray to extinguish a given fire. Factors such as fuel properties, enclosure effects (which are a function of ventilation and heat confinement), spray flux density, and spray velocity (momentum) are all involved in determining whether a fire will be extinguished. The "momentum" of an element of spray is the product of its velocity and the mass of dispersed water droplets (i.e., the mass flow rate). It must be stressed that the term *velocity* implies direction as well as speed. It is the momentum of a mist in a particular direction, relative to the direction of flow of the hot fire gases, that enhances cooling and suppression effectiveness. Opposing directional flows bring about turbulent mixing, hence improved cooling. Therefore, all three variables — drop size distribution, flux density, and velocity — are involved in determining the ability to extinguish a fire in a given scenario.

**A.3.3.21.2 Hybrid Water Mist Nozzles.** The actuation of a hybrid water mist nozzle can be by a built-in detection and activation device and/or by an independent means of activation.

**A.3.3.22.5 Pre-engineered Water Mist Systems.** These systems have the specific pipe size, maximum and minimum pipe lengths, flexible hose specifications, number of fittings, and number and types of nozzles prescribed by a testing laboratory. Systems are provided with either a self-contained or an external water supply. Based on actual test fires, the hazards protected by these systems are specifically limited as to type and size by a testing laboratory. Limitations on hazards that are allowed to be protected by these systems are contained in the manufacturer's installation manual, which is referenced as part of the listing.

**A.4.1** A water mist system is a fire protection system using very fine water sprays (i.e., water mist). The very small water droplets allow the water mist to control or extinguish fires by cooling of the flame and fire plume, oxygen displacement by water vapor, and radiant heat attenuation.

Water mist systems have been proven effective in controlling, suppressing, or extinguishing many types of fires. Potential applications include the following:

- (1) Gas jet fires
- (2) Flammable and combustible liquids
- (3) Hazardous solids, including fires involving plastic foam furnishings
- (4) Protection of aircraft occupants from an external pool fire long enough to provide time to escape
- (5) Ordinary (Class A) combustible fires such as paper, wood, and textiles
- (6) Electrical hazards, such as transformers, switches, circuit breakers, and rotating equipment
- (7) Electronic equipment, including telecommunications equipment

**A.4.1.1.2** In special cases, where adequate safeguards have been provided, water mist systems for the protection of structures, equipment, or personnel in the presence of such materials as described in 4.1.1.2 can be permitted.

**A.4.2** In the event of a fire, safeguards should be provided to ensure the following:

- (1) Prompt evacuation of trapped personnel
- (2) Prevention of entry by personnel into hazardous atmospheres
- (3) Provision of means for prompt rescue of any trapped personnel

Safety factors such as personnel training, warning signs, discharge alarms, self-contained breathing apparatus, evacuation plans, and fire drills should be considered.

Water mist is unlikely to present any significant hazard to personnel in most applications; however, direct impingement of the water mist could present an eye hazard. Noise during operation of the water mist systems could be a hazard to hearing. Water mist can reduce visibility and increase the time and difficulty in egress from an affected compartment.

**A.4.2.1** As used in this standard, *clearance* is the air distance between water mist system equipment, including piping and nozzles, and unenclosed or uninsulated live electrical components at other than ground potential. The minimum clearances provided are for the purpose of electrical clearance during nonemergency operating conditions; they are not intended for use as clearance distances during water mist system operation.

**A.4.2.1.1** All system components should be located so as to maintain minimum clearances from live parts, as shown in Table A.4.2.1.1.

**Table A.4.2.1.1 Clearance from Water Mist Equipment Live Uninsulated Electrical Components\***

| Nominal System Voltage (kV) | Maximum System Voltage (kV) | Design BIL <sup>†</sup> (kV) | Minimum Clearance* |     |
|-----------------------------|-----------------------------|------------------------------|--------------------|-----|
|                             |                             |                              | mm                 | in. |
| To 13.8                     | 14.5                        | 110                          | 178                | 7   |
| 23                          | 24.3                        | 150                          | 254                | 10  |
| 34.5                        | 36.5                        | 200                          | 330                | 13  |
| 46                          | 48.5                        | 250                          | 432                | 17  |
| 69                          | 72.5                        | 350                          | 635                | 25  |
| 115                         | 121                         | 550                          | 1067               | 42  |
| 138                         | 145                         | 650                          | 1270               | 50  |
| 161                         | 169                         | 750                          | 1473               | 58  |
| 230                         | 242                         | 900                          | 1930               | 76  |
|                             |                             | 1050                         | 2134               | 84  |
| 345                         | 362                         | 1050                         | 2134               | 84  |
|                             |                             | 1300                         | 2642               | 104 |
| 500                         | 550                         | 1500                         | 3150               | 124 |
|                             |                             | 1800                         | 3658               | 144 |
| 765                         | 800                         | 2050                         | 4242               | 167 |

\* For voltages up to 161 kV, the clearances are taken from NFPA 70, *National Electrical Code*. For voltages 230 kV and above, the clearances are taken from Table 124 of ANSI C2, *National Electrical Safety Code*.

<sup>†</sup> BIL values are expressed as kilovolts (kV), the number being the crest value of the full wave impulse test that the electrical equipment is designed to withstand. For BIL values that are not listed in the table, clearances can be found by interpolation.

The clearances in Table A.4.2.1.1 are for altitudes of 1000 m (3300 ft). The clearance should be increased at the rate of 1 percent for each 100 m (330 ft) increase in altitude above 1000 m (3300 ft).

**A.5.1.3.2** The water mist system manufacturer should be consulted regarding proper selection of piping and component materials to eliminate potential corrosion.

**A.5.2.2.1** Local building codes specify minimum requirements for seismic restraint or bracing.

**A.5.2.2.2** Independent inspection and certification is recommended for gas and water containers.

**A.5.3.1** Historically, small-orifice systems had a track record of nozzle blockage due to products of corrosion, water quality, and flaking of pipe coatings. Therefore, it is important to select pipe or tube for water mist systems that exhibits minimal corrosion.

With regard to flaking, current standards for galvanized piping cannot ensure that the coating will not flake and obstruct nozzles and strainers. The committee is aware of new technologies and processes that are working to address these issues. Once uniform manufacturing and testing standards are available, the committee will review these technologies for inclusion in NFPA 750.

**A.5.3.2** Hot-dipped galvanized steel pipe is not considered equivalent to piping specified in Table 5.3.3.1. For additional information on galvanized pipe, see A.5.3.1.

**A.5.3.4.1** The FSSA *Pipe Design Handbook for Use with Special Hazards Fire Suppression Systems* provides guidance on how to apply the ASME B31.1, *Power Piping Code*.

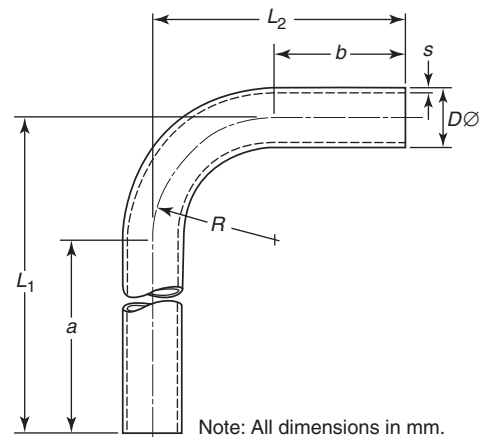
**A.5.3.4.4** Listed flexible connections can be permitted. Flexible connections for water mist installations should be kept as

short as possible and should be protected against mechanical injury.

**A.5.3.6** See Figure A.5.3.6 and Table A.5.3.6.

**A.5.4.1** It is important to select fittings for water mist systems that exhibit minimal corrosion because of the potential for clogging the water mist nozzles.

**A.5.4.2.2** Rubber-gasketed pipe fittings and couplings should not be installed where ambient temperatures can be expected to exceed 66°C (150°F), unless listed for such service. If the manufacturer further limits a given gasket compound, those recommendations should be followed.



**FIGURE A.5.3.6 Installation of Measurements for Application of Table A.5.3.6.**

Table A.5.3.6 Recommended Minimum Bending Radii for Different Sizes of Tube

| Tube O.D. (mm) | Tolerance± (mm) | Wall Thickness, S (mm) | Tube I.D. (mm) | Bending Radius, R (mm) | Leg length (mm) |     | Length (mm)    |                | Weight (kg/piece) |
|----------------|-----------------|------------------------|----------------|------------------------|-----------------|-----|----------------|----------------|-------------------|
|                |                 |                        |                |                        | a               | b   | L <sub>1</sub> | L <sub>2</sub> |                   |
| 16             | 0.08            | 2                      | 12             | 30                     | 200             | 40  | 230            | 70             | 0.198             |
| 18             | 0.08            | 1.5                    | 15             | 36                     | 200             | 35  | 236            | 71             | 0.178             |
| 20             | 0.08            | 2                      | 16             | 36                     | 200             | 45  | 236            | 81             | 0.268             |
| 20             | 0.08            | 2.5                    | 15             | 36                     | 200             | 45  | 236            | 81             | 0.326             |
| 22             | 0.08            | 1.5                    | 19             | 38                     | 200             | 40  | 238            | 78             | 0.227             |
| 22             | 0.08            | 2                      | 18             | 38                     | 200             | 40  | 238            | 78             | 0.296             |
| 25             | 0.08            | 2                      | 21             | 44                     | 200             | 50  | 244            | 94             | 0.362             |
| 25             | 0.08            | 2.5                    | 20             | 44                     | 200             | 50  | 244            | 94             | 0.442             |
| 25             | 0.08            | 3                      | 19             | 44                     | 200             | 50  | 244            | 94             | 0.519             |
| 28             | 0.08            | 1.5                    | 25             | 48                     | 200             | 50  | 248            | 98             | 0.319             |
| 28             | 0.08            | 2                      | 24             | 48                     | 200             | 50  | 248            | 98             | 0.417             |
| 28             | 0.08            | 3                      | 22             | 48                     | 200             | 50  | 248            | 98             | 0.601             |
| 30             | 0.08            | 2.5                    | 25             | 50                     | 200             | 60  | 250            | 110            | 0.575             |
| 30             | 0.08            | 3                      | 24             | 50                     | 200             | 60  | 250            | 110            | 0.677             |
| 30             | 0.08            | 4                      | 22             | 50                     | 200             | 60  | 250            | 110            | 0.869             |
| 35             | 0.15            | 2                      | 31             | 60                     | 200             | 65  | 260            | 125            | 0.586             |
| 35             | 0.15            | 3                      | 29             | 60                     | 200             | 65  | 260            | 125            | 0.852             |
| 38             | 0.15            | 2.5                    | 33             | 65                     | 200             | 75  | 265            | 140            | 0.827             |
| 38             | 0.15            | 3                      | 32             | 65                     | 200             | 75  | 265            | 140            | 0.979             |
| 38             | 0.15            | 4                      | 30             | 65                     | 200             | 75  | 265            | 140            | 1.268             |
| 38             | 0.15            | 5                      | 28             | 65                     | 200             | 75  | 265            | 140            | 1.538             |
| 42             | 0.2             | 2                      | 38             | 80                     | 200             | 85  | 280            | 165            | 0.809             |
| 42             | 0.2             | 3                      | 36             | 80                     | 200             | 85  | 280            | 165            | 1.183             |
| 50             | 0.2             | 6                      | 38             | 180                    | 150             | 150 | 310            | 310            | 3.451             |
| 65             | 0.35            | 10                     | 45             | 250                    | 160             | 160 | 330            | 330            | 9.840             |

For U.S. units, 25.4 mm = 1 in.; 0.4536 kg = 1 lb.

**A.5.6.1** In recognition of the future value of scientifically based fire protection system engineering or design methods but in consideration of the fact that the present water mist technology base is likely incomplete for general system design purposes, it is recommended that the nozzle-listing agencies collect and report to the manufacturer the following data for possible future use as required listing information:

*Calculation of the Cumulative Volumetric Distribution of Water Droplets.* The cumulative volumetric distribution of water droplets is to be reported as the flow rate per unit area weighted distribution of water droplets measured at the 24 locations shown in Figure A.5.6.1(a), as a minimum. The radial array of measurement locations is to be positioned symmetrically about the central axis of the water mist nozzle. Additional data can be included in the weighted average calculation by rotating the complete measurement location array (totaling 48 locations) by 22.5 degrees relative to the first set of locations. The nozzle spray pattern's diameter  $D$ , utilized for calculating the radial distances to the measurement locations, is to be determined utilizing the spray envelope methodology of A.5.6.1, Water Discharge Distribution, at 1.0 m (39.4 in.) below the tip of the nozzle.

Water discharge distribution measurements in a plane oriented perpendicular to the central axis of the nozzle and 1.0 m (39.4 in.) below the tip are to be conducted using 0.305 m × 0.305 m (1 ft × 1 ft) collection pans centered on the radial measurement locations and oriented as shown in Figure A.5.6.1(a). In the case of spray pattern diameters less than 3.05 m (10 ft), multiple discharge tests are to be performed to avoid physical interference between the pans.

Droplet size distribution measurements in a plane oriented perpendicular to the central axis of the nozzle and 1.0 m (39.4 in.) below the tip are to be conducted at each of the 24 measurement locations shown in Figure A.5.6.1(a).

The droplet size distribution and water discharge distribution measurements are to be made at the minimum and maximum rated pressure of the nozzle. The droplet size distribution at each measurement location and pressure is to be weighted proportionally against the corresponding relative flow rate per unit area of water discharge. The nozzle droplet size distribution is to be reported as a single summation of the weighted cumulative count and volume percent droplet distributions for all measurement locations. The summation can be calculated using the following series of formulas and presented in a chart such as that shown in Figure A.5.6.1(b):

- (1) For a single measurement location,  $x$ , and bin size,  $y$ :
  - (a) Cumulative count percent (single bin),

$$c_y = \frac{n_y}{n_x} + c_{y-1}$$

where:

- $n_y$  = number of droplets in a single bin size for location  $x$
- $n_x$  = total number of droplets in the sample at location  $x$

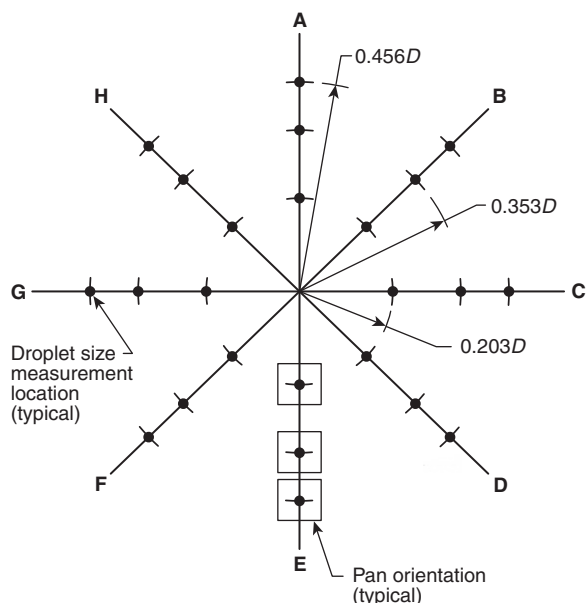


FIGURE A.5.6.1(a) Droplet Size Measurement Locations.

- (b) Proportional flow rate per unit area,

$$p_x = \frac{f_x}{F}$$

where:

$f_x$  = flow rate per unit area at location  $x$   
 $F$  = total cumulative flow rate for all locations,

$$\sum f_x$$

- (c) Flow weighted cumulative count percent (single bin),

$$w_y = c_y p_x + w_{y-1}$$

The preceding equations are to be used for all locations and all bin sizes.

- (2) For the summation of all measurement location data:

- (a) Flow weighted cumulative count percent (single bin),

$$c_y = \sum w_y$$

- (b) Flow weighted cumulative volume (single bin),

$$V1_y = \frac{(\pi b_y^3)}{6} (c_y - c_{y-1}) + V_{y-1}$$

where:

$b_y$  = minimum diameter for bin size  $y$

- (c) Flow weighted cumulative volume percent (single bin),

$$V2_y = \frac{V1_y}{\sum V1_y}$$

ASTM E 799, *Standard Practice for Determining Data Criteria and Processing for Liquid Drop Size Analysis*, is to be used for guidance in performing the droplet size distribution measurements, including determination of appropriate size class

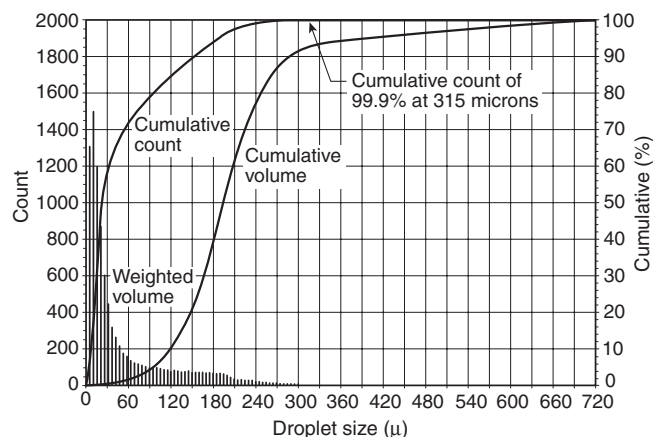


FIGURE A.5.6.1(b) Example of Flow Rate per Unit Area Weighted Droplet Size Distribution.

bounds and the minimum-to-maximum droplet diameter range at each location.

*Method 2 for Calculating a Weighted Average Drop Size Distribution Curve.* The following spreadsheet method can be used to obtain a statistically representative measurement of the drop size distribution of a water spray:

- Determine the diameter ( $D$ ) of the spray cone at a distance 1 m below the nozzle.
- As shown in Figure A.5.6.1(a), the locations for measuring drop size distribution are calculated as  $0.203 \times D$ ,  $0.353 \times D$ , and  $0.456 \times D$ , from the center axis of the spray cone. Measuring at these locations guarantees that all the sample areas,  $A_i$ , are equal. Calculate  $A_i$  as the area of the cone of diameter ( $D$ ) divided by the number of sample points (preferably 24).
- Measure the flux density ( $V_i$ ) at each position at which the drop size distribution will be measured. This can be done by placing collector pans exactly at the points of interest. If the pan locations do not coincide exactly with the drop size measurement locations, plot the flux density profile along the axis of interest and read off the  $V_i$  value for the correct location. The method for calculating the weighted average is expressed as

$$R_k = \frac{\sum_i (R_{j,i} \times A_i \times V_i)}{\sum_i (A_i \times V_i)}$$

where:

$R_k$  = weighted cumulative volume percent readings

for drop sizes equal to and less than  $d_{upper}$

$R_{j,i}$  = cumulative volume percent readings for drop sizes equal to and less than  $d_{upper}$  at location  $i$

$A_i$  = area centered at location  $i$  in which the drop size distribution can be closely represented by  $R_k$

$V_i$  = water flux density measured at location  $i$

- Use a drop sizing instrument conforming to ASTM E 799, *Standard Practice for Determining Data Criteria and Processing for Liquid Drop Size Analysis*, to measure the drop size distribution at the point determined in Step 2. One of the outputs from such an instrument is a table of cumulative percent volume versus diameter bins, defined by the upper and lower diameters of a range of drop sizes. Using the

upper bin diameter ( $d_{upper}$ ) ensures that the resulting plot can be interpreted as “ $R$  percent of the mass . . . in drops of diameter ‘less than’  $d_k$ .” These data must be input into a spreadsheet like that shown in Table A.5.6.1. Then, using the  $V_i$ , or flux density measured at the location  $i$ , and the area  $A_i$  that the measurement represents, calculate the weighted average drop size distribution,  $R_k$ .

**Water Discharge Distribution:** Water discharge distribution in a plane 1.0 m (3.3 ft) below and perpendicular to the central axis of the nozzle using 0.305 m × 0.305 m (1 ft × 1 ft) collection pans. The water distribution measurements are to be made at the minimum- and maximum-rated operating pressures of the nozzle and over an area sufficient to collect at least 90 percent of the water discharge.

**Nozzle Spray Profile:** Profile of the nozzle spray envelope encompassing at least 90 percent of the water discharge, measured from the tip of the nozzle and extending over the effective range determined from the listing investigation. The profile of the nozzle spray envelope is to be provided at the

minimum- and maximum-rated operating pressures of the nozzle as well as over the intended range of orientation angles if in other than the vertically down orientation.

**Spray Thrust Force:** Spray thrust force as measured in a plane perpendicular to the central axis of the nozzle, at a distance of 0.305 m (1 ft) below the nozzle and over an area sufficient to capture at least 90 percent of the water discharge. The measurements are to be made at the minimum- and maximum-rated operating pressures of the nozzle. For fire test purposes, the maximum distance from test fires should be considered as one of the following:

- (1) The manufacturer’s maximum spacing of nozzles from walls or one-half of the manufacturer’s recommended maximum spacing between nozzles, whichever is greater
- (2) The manufacturer’s recommended placement of nozzles with regard to local hazard protection

**A.5.8.2** The strainer or filter should be sized to include the head loss for a period that is estimated to be ample, taking into

**Table A.5.6.1 Sample Spreadsheet Illustrating the Calculation of a Weighted Average Drop Size Distribution Plot, Using Drop Size Distribution Data for Two Measurement Points Only**

| Diameter (µ)   | First Measurement Location<br>$V_i = 6.7; A_i = 0.10$ |                                  |                            |                             | Second Measurement Location<br>$V_i = 10.0; A_i = 0.10$ |                                      |                            |                             | Denominator<br>$\Sigma (V_i \times A_i)$<br>(L/min) | Numerator<br>$\Sigma (R_{j,i} \times V_i \times A_i)$ | Wtd. R (%) |
|----------------|---|----------------------------------|----------------------------|-----------------------------|---|--------------------------------------|----------------------------|-----------------------------|---|---|------------|
|                | $R_{j,i} = 1\%$                                       | $V_i$<br>(L/min/m <sup>2</sup> ) | $A_i$<br>(m <sup>2</sup> ) | $R_j \times V_i \times A_i$ | $R_{j,i} = 2\%$   | $V_i = 2$<br>(L/min/m <sup>2</sup> ) | $A_i$<br>(m <sup>2</sup> ) | $R_j \times V_i \times A_i$ |   |   |            |
| Upper Diameter |   |                                  |                            |                             |   |                                      |                            |                             |   |   |            |
| 1128           | 100.0   | 6.7                              | 0.10                       | 67.0                        | 100.0   | 10.0                                 | 0.10                       | 100.0                       | 1.67  | 167.0   | 100.0      |
| 973            | 100.0   | 6.7                              | 0.10                       | 67.0                        | 100.0   | 10.0                                 | 0.10                       | 100.0                       | 1.67  | 167.0   | 100.0      |
| 840            | 99.9  | 6.7                              | 0.10                       | 66.9                        | 100.0   | 10.0                                 | 0.10                       | 100.0                       | 1.67  | 166.9   | 100.0      |
| 724            | 99.9  | 6.7                              | 0.10                       | 66.9                        | 100.0   | 10.0                                 | 0.10                       | 100.0                       | 1.67  | 166.9   | 100.0      |
| 625            | 99.9  | 6.7                              | 0.10                       | 66.9                        | 100.0   | 10.0                                 | 0.10                       | 100.0                       | 1.67  | 166.9   | 99.9       |
| 539            | 99.9  | 6.7                              | 0.10                       | 66.9                        | 99.9  | 10.0                                 | 0.10                       | 99.9                        | 1.67  | 166.8   | 99.9       |
| 465            | 99.8  | 6.7                              | 0.10                       | 66.9                        | 99.9  | 10.0                                 | 0.10                       | 99.9                        | 1.67  | 166.8   | 99.8       |
| 401            | 99.1  | 6.7                              | 0.10                       | 66.4                        | 99.9  | 10.0                                 | 0.10                       | 99.9                        | 1.67  | 166.3   | 99.6       |
| 346            | 97.7  | 6.7                              | 0.10                       | 65.5                        | 99.8  | 10.0                                 | 0.10                       | 99.9                        | 1.67  | 165.4   | 99.0       |
| 299            | 95.4  | 6.7                              | 0.10                       | 63.9                        | 99.6  | 10.0                                 | 0.10                       | 99.8                        | 1.67  | 163.7   | 98.0       |
| 258            | 92.7  | 6.7                              | 0.10                       | 62.1                        | 99.4  | 10.0                                 | 0.10                       | 99.6                        | 1.67  | 161.7   | 96.8       |
| 222            | 86.2  | 6.7                              | 0.10                       | 57.8                        | 98.9  | 10.0                                 | 0.10                       | 99.4                        | 1.67  | 157.2   | 94.1       |
| 192            | 73.1  | 6.7                              | 0.10                       | 49.0                        | 97.1  | 10.0                                 | 0.10                       | 98.9                        | 1.67  | 147.9   | 88.6       |
| 165            | 55.8  | 6.7                              | 0.10                       | 37.4                        | 93.5  | 10.0                                 | 0.10                       | 97.1                        | 1.67  | 134.5   | 80.5       |
| 143            | 37.4  | 6.7                              | 0.10                       | 25.1                        | 88.3  | 10.0                                 | 0.10                       | 88.3                        | 1.67  | 113.4   | 67.9       |
| 123            | 24.4  | 6.7                              | 0.10                       | 16.3                        | 77.2  | 10.0                                 | 0.10                       | 77.2                        | 1.67  | 93.5  | 56.0       |
| 106            | 19.2  | 6.7                              | 0.10                       | 12.9                        | 62.9  | 10.0                                 | 0.10                       | 62.9                        | 1.67  | 75.8  | 45.4       |
| 91.7           | 15.7  | 6.7                              | 0.10                       | 10.5                        | 48.8  | 10.0                                 | 0.10                       | 48.8                        | 1.67  | 59.3  | 35.5       |
| 79.1           | 13.4  | 6.7                              | 0.10                       | 9.0                         | 38.4  | 10.0                                 | 0.10                       | 38.4                        | 1.67  | 47.4  | 28.4       |
| 68.2           | 11.1  | 6.7                              | 0.10                       | 7.4                         | 31.4  | 10.0                                 | 0.10                       | 31.4                        | 1.67  | 38.8  | 23.2       |
| 58.9           | 7.8   | 6.7                              | 0.10                       | 5.2                         | 26.2  | 10.0                                 | 0.10                       | 26.2                        | 1.67  | 31.4  | 18.8       |
| 50.8           | 5.4   | 6.7                              | 0.10                       | 3.6                         | 21.4  | 10.0                                 | 0.10                       | 21.4                        | 1.67  | 25.0  | 15.0       |
| 43.8           | 4.4   | 6.7                              | 0.10                       | 2.9                         | 16.7  | 10.0                                 | 0.10                       | 16.7                        | 1.67  | 19.6  | 11.7       |
| 37.8           | 3.9   | 6.7                              | 0.10                       | 2.6                         | 12.7  | 10.0                                 | 0.10                       | 12.7                        | 1.67  | 15.3  | 9.2        |
| 32.6           | 3.6   | 6.7                              | 0.10                       | 2.4                         | 9.9   | 10.0                                 | 0.10                       | 9.9                         | 1.67  | 12.3  | 7.4        |
| 28.1           | 3.0   | 6.7                              | 0.10                       | 2.0                         | 8.4   | 10.0                                 | 0.10                       | 8.4                         | 1.67  | 10.4  | 6.2        |
| 24.3           | 2.2   | 6.7                              | 0.10                       | 1.5                         | 7.4   | 10.0                                 | 0.10                       | 7.4                         | 1.67  | 8.9   | 5.3        |
| 20.9           | 1.4   | 6.7                              | 0.10                       | 0.9                         | 6.5   | 10.0                                 | 0.10                       | 6.5                         | 1.67  | 7.4   | 4.4        |
| 18.1           | 0.9   | 6.7                              | 0.10                       | 0.6                         | 5.6   | 10.0                                 | 0.10                       | 5.6                         | 1.67  | 6.2   | 3.7        |
| 15.6           | 0.6   | 6.7                              | 0.10                       | 0.4                         | 4.3   | 10.0                                 | 0.10                       | 4.3                         | 1.67  | 4.7   | 2.8        |
| 13.4           | 0.4   | 6.7                              | 0.10                       | 0.3                         | 2.9   | 10.0                                 | 0.10                       | 2.9                         | 1.67  | 3.2   | 1.9        |
| 11.6           | 0.0   | 6.7                              | 0.10                       | 0.0                         | 0.0   | 10.0                                 | 0.10                       | 0.0                         | 1.67  | 0.0   | 0.0        |

No reproduction or networking permitted without license from IHS

account the type of protection provided, the condition of the water, and similar local circumstances.

**A.5.9.1.5** Vibration problems with gauges may be addressed by using liquid-filled gauges and/or snubbers. Where the vibrations are severe, they can be addressed with flexible connectors rated for the appropriate pressures.

**A.5.10.2.1** Detectors installed at the maximum spacing as listed or approved for fire alarm use could result in excessive delay in water mist system actuation, especially where more than one detection device is required to be in alarm before automatic actuation results.

**A.5.10.3.7** The interaction of the water mist system with production equipment and with environmental control systems should be carefully evaluated to determine which systems should be shut down and which should continue to operate when the water mist system is activated. For example, fuel supplies, ignition sources, ventilation systems, and material handling equipment should be evaluated to determine their impact on the performance of the water mist system.

**A.5.10.4.3.1** Where installations are exposed to conditions that lead to loss of integrity of the pneumatic lines, special precautions shall be taken to ensure that no loss of integrity occurs.

**A.6.2.2.2** The simultaneous operation of all nozzles in the space should be achieved by the use of pilot activation nozzles, automatic nozzles, or an independent detection system.

**A.6.2.3** Care should be taken to thoroughly evaluate and correct any factors that could result in unwanted system discharge.

In zoned water mist systems, the effect of water mist migrating into adjacent zones could activate unwanted releases with standard smoke detectors. Care needs to be given to match detection devices to the environment in both normal and release conditions.

**A.6.5** Single-fluid and twin-fluid systems can be operated in the low, intermediate, or high pressure range.

(1) *Single-Fluid Media Systems.* A single-fluid media system requires one set of distribution piping to transport the fluid to each nozzle. Single-fluid media systems should produce water mist (droplet production) by one of the means specified as follows:

- Liquid should be discharged at a high velocity with respect to the surrounding air. The difference in velocities between the liquid and surrounding air should shear the liquid into small droplets.
- A liquid stream is impinged upon a fixed surface. The impact of the liquid on the surface breaks the liquid stream into small droplets.
- Two liquid streams of similar composition collide with one another. The collision of the two streams breaks the individual streams into small droplets.
- Liquid is either vibrated or electrically broken into small droplets (ultrasonic and electrostatic atomizers).
- Liquid is heated above its boiling point in a pressurized container and released suddenly to atmospheric pressure (flashing liquid sprays).

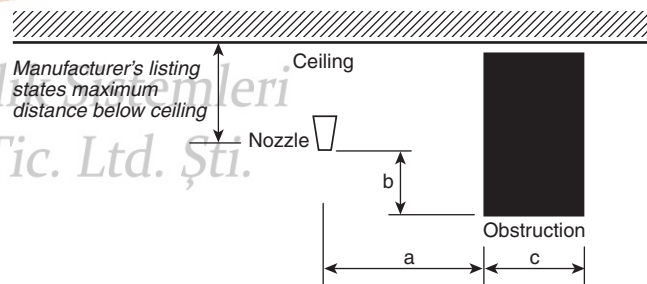
(2) *Twin-Fluid Media Systems.* Twin-fluid media systems produce water mist (droplet production) by impingement of two fluids delivered from separate piping systems. One set of piping provides a liquid (water) to the nozzle, and the second piping network provides an atomizing fluid/media.

**A.7.2.5** Spray that strikes obstructions too close to the nozzle will not fully atomize, and a portion of the water mass will be removed from suspension in the space. Water mist that impacts directly on surfaces will not be available as fine droplets for heat absorption, radiation attenuation, or evaporation. Such losses diminish the extinguishing effectiveness of total flooding or local application systems. For Class A fire scenarios where prewetting of combustibles is an important factor in preventing fire growth, obstructions to spray development prevent wetting of unburned materials and diminish the performance of the system.

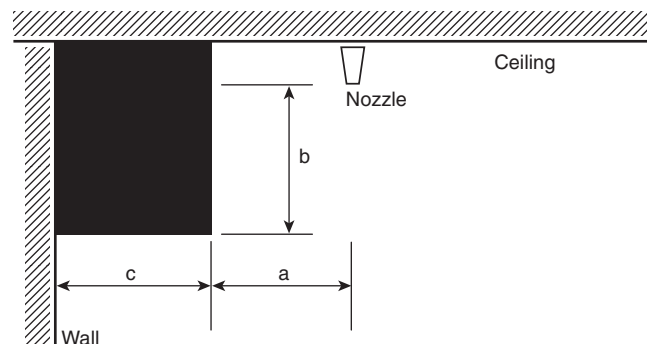
Water mist nozzles are produced with a wide range of spray patterns, spray velocity, and projection distances. The degree to which obstructions can affect the performance of water mist protection differs according to the type of spray technology and the type of application.

Obstructions can have less of an effect on performance for total flooding type water mist systems than local application or sprinkler equivalent applications. Therefore, each manufacturer should provide guidance on how to address obstructions with their particular technology. The following diagrams indicate the type of information on spacing that should be provided in the manufacturer's design installation, operations, and maintenance (DIOM) manual or other documentation provided by the listing. Additional nozzles can be required to ensure complete water mist fire protection when obstructions and maximum coverage distances to obstructions are not evaluated as part of the manufacturer's listing.

Manufacturer's documentation should provide the "a" and "b" dimensions indicated in Figure A.7.2.5(a) and Figure A.7.2.5(b) on how to position nozzles relative to continuous obstructions of width "c" formed by beams, ducts,



**FIGURE A.7.2.5(a) Dimensions to Be Considered for Locating Nozzles Relative to Beam, Duct, or Other Continuous Obstruction.**



**FIGURE A.7.2.5(b) Position of Nozzle Relative to Beam, Duct, or Other Continuous Obstruction Against a Wall.**

or similar continuous obstructions so as to ensure that the system will perform as intended by the listing.

Where water mist nozzles are spaced on opposite sides of a continuous obstruction, the distance between them should not exceed the allowable distance between nozzles. The manufacturer's documentation should provide guidance on the "a," "b," and "c" dimensions indicated in Figure A.7.2.5(c).

*Obstructions located below water mist nozzles.* The manufacturer's DIOM documentation should provide information on how to address continuous horizontal or vertical obstructions that interrupt the spray pattern in a horizontal plane below the water mist nozzle. Both horizontal and vertical obstructions below nozzles should be considered, as illustrated in Figure A.7.2.5(d) and Figure A.7.2.5(e).

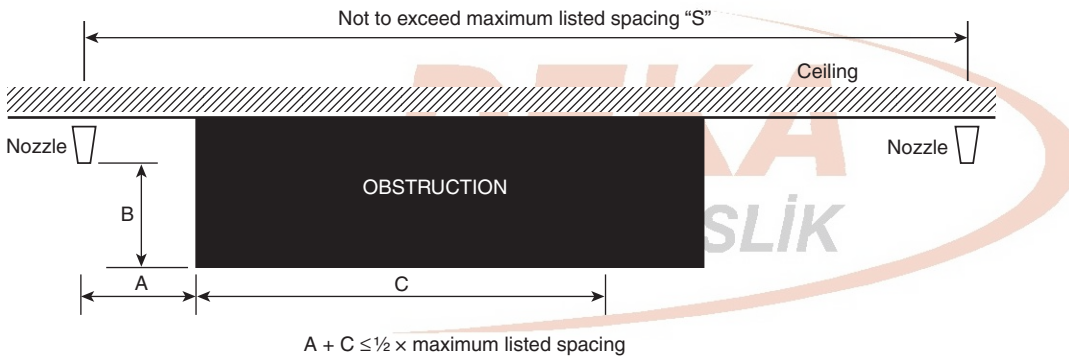
*Obstructions located below nozzles.* Where a continuous obstruction is located below a nozzle and within the spray pattern as indicated in Figure A.7.2.5(d), the manufacturer's DIOM manual should address how to place the nozzle so that the obstruction does not adversely affect the formation of the spray or the performance of the system.

*Suspended or floor-mounted vertical obstructions.* Where continuous vertical obstructions such as privacy curtains, free-standing partitions, room dividers, and similar obstructions are located below a nozzle and within the spray pattern as indicated in Figure A.7.2.5(e), the manufacturer's design documentation should address how to place the nozzle so that the obstruction does not adversely affect the formation of the spray or the effectiveness of the system.

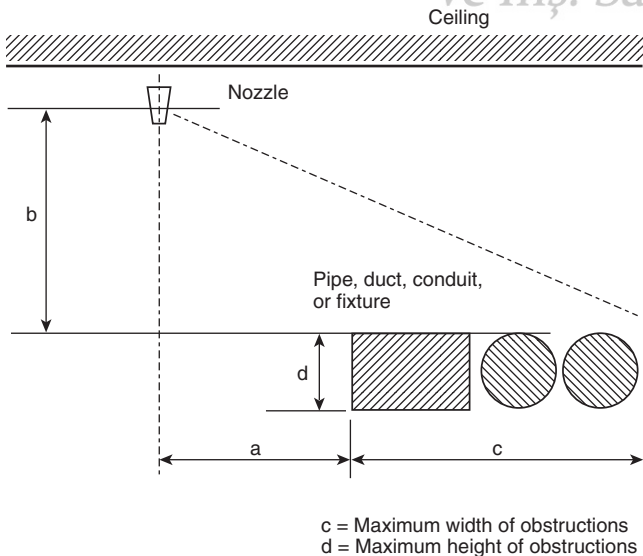
*Positioning water mist nozzles for horizontal discharge.* The manufacturer's documentation should address how to locate nozzles designed for horizontal discharge relative to obstructions, as indicated in Figure A.7.2.5(f) and Figure A.7.2.5(g).

**A.7.3.8** The FSSA *Pipe Design Handbook for Use with Special Hazards Fire Suppression Systems* provides guidance on pipe support and hangers.

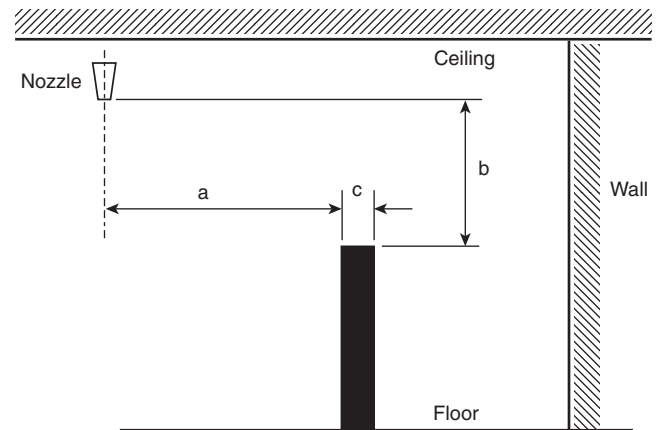
**A.7.5.3** When the storage container(s) is placed in the hazard area being protected, provisions should be made to ensure that the system operation is not adversely affected by its location.



**FIGURE A.7.2.5(c) Dimensions Governing the Position of Nozzles on Either Side of a Continuous Obstruction.**

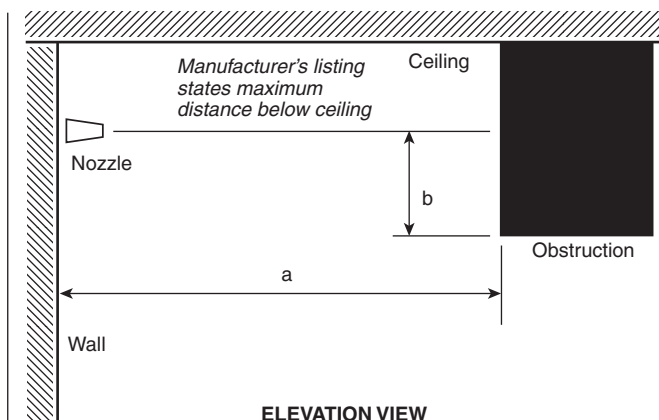


**FIGURE A.7.2.5(d) Dimensional Considerations for Nozzles Located Above Continuous Horizontal Obstructions Such as Ducts, Pipes, Cable Trays, and Light Fixtures.**

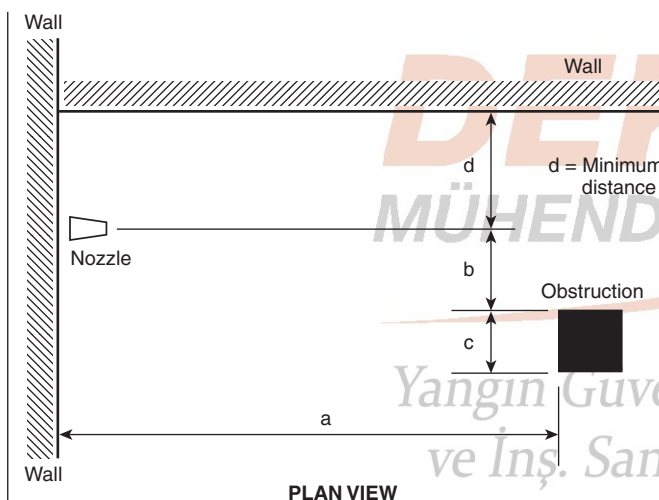


**FIGURE A.7.2.5(e) Dimensional Considerations for Suspended or Floor-Mounted Continuous Obstruction Under a Water Mist Nozzle.**

No reproduction or networking permitted without license from IAB



**FIGURE A.7.2.5(f) Dimensional Considerations for Locating a Sidewall or Horizontally Discharging Water Mist Nozzle with Respect to the Ceiling and a Continuous Obstruction Within the Spray Path.**



**FIGURE A.7.2.5(g) Dimensional Considerations for Locating a Horizontally Discharging Water Mist Nozzle with Respect to an Obstruction in the Spray Path, Such as a Column or a Parallel Wall.**

**A.7.6.1** To ensure that pump output is sufficient for the maximum system demand, it is common engineering practice to provide a margin of safety by selecting a pump whose performance curve falls above the maximum system demand. For further discussion concerning the sizing and selection of pumps, see A.11.2.

**A.7.9.1.2** To prevent system impairment from two or more ground faults or a single open circuit condition, Class A circuits should be considered.

**A.7.9.1.3** Where signaling line circuits are used for zoned (multiple input and output) water mist systems, it is important that circuits be capable of transmitting an alarm signal during a single open or a nonsimultaneous ground fault on a circuit conductor to ensure reliable performance.

**A.7.9.3.1** Detectors installed at the maximum spacing as listed or approved for fire alarm use can result in excessive delay in agent release, especially where more than one detection device is required to be in alarm before automatic actuation results.

**A.7.10.1** The test connection is intended to permit a flow of agent to the most hydraulically remote point, to confirm that piping is properly connected and in service. This connection will also permit testing of flow alarms for the system.

**A.8.1** Currently, no generic design method is recognized for water mist protection systems. The relationship between flux density or nozzle spacing and performance in controlling fires is not consistent between systems designed by different manufacturers. The system features, such as nozzle spacing, flow rate, drop size distribution, cone angle, and other characteristics, need to be determined for each manufacturer's system through full-scale fire testing to obtain a listing for each specific application.

**A.8.2 Results.** The results of the listing testing should identify the following:

- (1) System flow rate (minimum and maximum)
  - (a) Flow rate per unit area (if applicable)
  - (b) Flow rate per unit volume (if applicable)
- (2) System operating pressure (minimum and maximum)
  - (a) Nozzle operating pressure range
  - (b) Pump/cylinder operating pressure range
  - (c) Pump inlet and outlet pressure and flow rate requirements
- (3) General water requirements
  - (a) Quantity/duration
  - (b) Quality
  - (c) Temperature
- (4) Nozzle characteristics
  - (a) Type(s)/model number(s)
  - (b) Flow rate (minimum and maximum)
  - (c) Operating pressure (minimum and maximum)
- (5) Nozzle spray characteristics
  - (a) Spray angle
  - (b) Drop size distribution
  - (c) Momentum/velocity
- (6) Nozzle installation parameters
  - (a) Distance above floor (minimum and maximum)
  - (b) Distance below ceiling (minimum and maximum)
  - (c) Distance above hazard (minimum and maximum)
  - (d) Nozzle spacing (minimum and maximum)
  - (e) Orientation
  - (f) Minimum distance from walls
  - (g) Minimum distance from obstructions
- (7) Activation device
  - (a) Type/model number
  - (b) Activation, temperature
  - (c) Activation, smoke obscuration
- (8) General design parameters
  - (a) Pipe requirements
    - i. Size
    - ii. Operating pressures/wall thicknesses
  - (b) Fittings
    - i. Type
    - ii. Operating pressure



- (c) Pumps
  - i. Valves, fittings, and filters
  - ii. Power requirements
  - iii. Operating pressure and flow rates
  - iv. Water requirements
- (d) Cylinders
  - i. Valves and fittings
  - ii. Capacity
  - iii. Operating pressures

**A.8.2.2 Test Fire Hazard.** The test fire hazard reflects the application specified in the listing. The test fires should be chosen such that the performance objectives of the system can be determined. If fire suppression or fire extinguishment is the preferred performance objective, and the fire tests are conducted inside a compartment, the test fires should be chosen such that the influence from the compartment is minimized (i.e., fire size not too large). If fire control is the preferred performance objective, the test fire sizes should be chosen in a way that the system's ability to limit the exposure from the fire can be evaluated (i.e., fire size not too small).

**A.8.3.1** The choice of a fire performance objective requires an understanding of the levels of water mist performance and an analysis of the protection needs of the hazard.

For some hazards, fire control will be sufficient. With fire control, growth of the fire is limited or stopped upon activation of the water mist system, but manual intervention will be required to complete extinguishment. The heat and products of combustion released during the time prior to extinguishment must be considered, along with the effect they will have on exposed equipment and stock. Fire control will limit the ceiling gas temperature so that structural damage is prevented.

If the potential for nonstructural damage is too great for the fire control option, fire suppression might be an acceptable performance objective. Fire suppression results in a sharp reduction in the heat released from the fire and prevention of its regrowth. Fire suppression also requires manual fire fighting to achieve extinguishment. Because the fire is less intense, the difficulty of manually extinguishing the fire is reduced, and is accomplished in less time, as opposed to a fire control performance objective. The results are less damage directly associated with the manual fire-fighting effort and less overall damage, due to the reduced intensity of the fire.

The highest level of water mist performance is obtained with a fire extinguishment performance objective. Fire extinguishment will completely and automatically suppress a fire until there are no burning combustibles. Fire extinguishment does not require manual fire fighting and results in the lowest potential for damage.

Some factors to consider when analyzing fire loss potential and selecting the most beneficial water mist performance objective are as follows:

- (1) *Life safety.* What effect could this fire have on the occupants? The means of egress must be maintained to allow all occupants safe travel. Also consider the effect that loss of use of fire damaged equipment could have, such as with marine applications or public transportation exposures. A higher performance objective could be needed if life safety is an issue.
- (2) *Time required to achieve extinguishment.* This time frame can vary from seconds, if the system is designed for extinguishment, to many minutes, if the system depends on the response of public fire-fighting personnel.
- (3) *Susceptibility of equipment and contents to the effects of the fire.* Sensitive equipment, such as electronics, and susceptible

products, such as pharmaceuticals, will benefit from reduced exposure to heat and products of combustion. Consideration should be given to the effect of radiant heat on nearby equipment. Fire suppression and fire extinguishment will result in a low potential for radiant heat damage, due to the reduced rate of heat release, compared to a fire control performance objective.

- (4) *Business interruption.* The potential effect of a fire on equipment or stock should be analyzed from a business interruption standpoint. The potential effect on the overall business due to loss of use of a critical piece of equipment or hard-to-replace stock is a major factor in selecting the most appropriate water mist performance objective. A vital piece of production equipment will generally demand a higher level of protection than a similarly valued piece of equipment that is not critical to continued production. Consideration should also be given to the effect the fire could have on dependent locations and customers.

**A.8.4.1** The construction of the enclosure should substantially contain the water mist in the vicinity of the hazard for a sufficient length of time to achieve the fire protection objectives of the water mist system. As with other water-based systems, consideration should be given to account for the pressure changes developed during the fire and the water mist discharge.

**A.8.4.1.2.1** Natural ventilation and openings in the compartment allow the hot gases layer (ceiling jet) to exhaust mist from the compartment, decreasing the extinguishing potential. The flow of gases into and out of the compartment also alters the mixing characteristics of the system, which, in turn, might require the additional momentum of the mist in order to overcome this alteration. Forced ventilation also significantly reduces the amount of mist in the compartment as well as affects the mixing characteristics of the system.

Prior to or concurrent with the operation of the water mist system, consideration should be given to automatic closing of doors and dampers, shutdown of electrical equipment, and shutdown of HVAC equipment.

**A.9.1.2** The addition of piping and nozzles to an existing water mist system can render the system ineffective if it leads to reduced pressure and flow. The existing piping does not have to be increased in size to compensate for additional nozzles, provided that the new work is calculated and the calculations include that portion of the existing system that is necessary to carry water or atomizing medium (if used) to the new work.

**A.9.1.4** Sectional control valves on high pressure systems can be electrically activated. Special valves are designed to permit use of low amperage solenoid valves. These valves typically cause a high friction loss across the seats. It is important that the hydraulic calculations reflect accurate values for such head losses. Information on flow characteristics of custom valves should be available as part of the listing information. This information will facilitate the hydraulic calculation process, and checking, if it is a requirement to provide accurate information on all special valves.

**A.9.2** The Hazen-Williams (H-W) equation cannot be corrected for flow velocity, water temperature, viscosity, or pipe-wall roughness factors, all of which significantly affect the degree of turbulence, hence the pressure losses in piping. Water mist systems in general, and intermediate and high pressure systems in particular [ $>12$  bar to 270 bar ( $>175$  psi to 4000 psi)], are likely to create conditions where there could be higher velocities, different water properties, or smaller diameter pipe than are used in low pressure systems. (As pipe diameters decrease, the relative effect of wall roughness increases.) Because it allows for input of

actual fluid properties, the Darcy–Weisbach (D–W) equation should be used instead of the H–W equation for intermediate and high pressure systems.

**A.9.2.2** These equations are equivalent:

$$f = \frac{1304.56 \times Re^{-0.1664} V^{0.0184}}{C^{1.852}}$$

$$f = \frac{1014.2 \times Re^{-0.148}}{C^{1.852} Dm^{0.0184}}$$

where:

- $f$  = Darcy–Weisbach friction factor
- $Re$  = Reynolds number
- $V$  = velocity in fps or m/s
- $C$  = Hazen–Williams roughness coefficient
- $Dm$  = pipe diameter in feet or meters

**A.9.3** Many low pressure water mist systems will be similar to standard fire protection systems, such as sprinklers (NFPA 13, *Standard for the Installation of Sprinkler Systems*) and water spray systems (NFPA 15, *Standard for Water Spray Fixed Systems for Fire Protection*). It is expected that piping materials, fittings, valves, and pipe sizes will be selected in accordance with those standards. These expectations imply that velocities in the piping will be in the same range as in sprinkler piping. This assumed similarity to sprinkler piping is the reason this standard accepts the use of the H–W equation for low pressure water mist systems.

Not all low pressure water mist system piping will necessarily be similar to sprinkler piping, however. The designer can choose to use small diameter piping to reduce system weight or to live with high friction losses in piping in order to be able to install piping in a restricted space, as in an aircraft cargo compartment. Use of small diameter piping will put the velocities higher than is “normal” in sprinkler piping, which introduces the probability that the H–W equation will not be accurate. Values of the friction loss coefficient,  $C$ , which is used in the H–W equation, are accurate only if the flow velocity is close to that at which the value of  $C$  was measured. It is a matter of judgment as to what velocity is too high for the H–W equation. American Water Works Association (AWWA) data list  $C$  factors measured at a velocity of 0.9 m/sec (3 ft/sec), yet it is accepted practice in sprinkler calculations to have velocities in sprinkler piping between 3.05 m/sec and 9.1 m/sec (10 ft/sec and 30 ft/sec).

Similarly, the tables of equivalent lengths for fittings and valves used by sprinkler system designers are based on fittings and valve types typical of sprinkler systems. Water mist systems can incorporate different types of fittings and valves for which the H–W–based equivalent length values will be incorrect. In the interest of “good practice,” the water mist system designer should use the D–W equation for low pressure system calculations when pipe sizes or other system features, such as the use of solenoid valves, differ significantly from normal sprinkler practices.

It is also important to note that the H–W equation contains no terms that account for the temperature. Hence, density and viscosity of the liquid also are not taken into account. It assumes that the water contains no additives and is close to 15.6°C (60°F). If viscosity or water temperature departs significantly from typical sprinkler system water supply conditions, the D–W equation should be used instead, regardless of the pressure regime or flow velocities.

**A.10.1.3** Although some water discharge might continue after the atomizing medium has been exhausted, it is not effective for fire suppression.

**A.10.2** Some water mist systems protect single hazards or areas. Other system designs are based on multiple zones with overlapping protection at the zone boundaries. It is also possible for one water mist system to provide local application protection for several individual hazards. Quantities of water and of atomizing media should be based on the most demanding location for the fire. For example, if a fire could start at the intersection of four zones, the water supply and the atomizing medium (if used) should be able to supply all four zones simultaneously. If a water mist system protects several individual hazards that are located in close proximity, it might be necessary to design for simultaneous operation of multiple local-application zones.

**A.10.3** The 30-minute water supply requirement applies to water supply capacity and does not require that the system actually discharge for 30 minutes. This minimum duration should be provided for all water mist systems that are installed for life safety purposes or for structural protection. For water mist systems designed to protect equipment or other special hazards in unoccupied areas, 10.3.1(1) allows the water supply duration to be determined in accordance with Chapter 8. Paragraph 10.3.1(3) provides for performance-based design of water mist systems by qualified fire protection engineers. It should be noted that, currently, there is no generally accepted method for performance-based design of a water mist system.

**A.10.4.1** An extra supply (connected reserve) of extinguishing agent (including additives and atomizing medium, if used) piped to feed into the automatic system should be considered on all installations. The reserve supply is normally actuated by manual operation of the main/reserve switch on either electrically operated or pneumatically operated systems. A connected reserve is desirable for the following reasons:

- (1) It provides improved reliability for systems used for protection of life safety.
- (2) It provides protection should a reflash occur.
- (3) It provides reliability should the main bank malfunction.
- (4) It provides protection of other hazards if selector valves are involved and multiple hazards are protected by the same set of cylinders.

**A.10.5.1** Algae and bacteriologic growth in stored water can clog the system by blocking the filters or strainers. Annual sampling or replacement of stored water is required by Table A.13.2.2.

Where water treatment of potable or natural seawater is required, nonchlorine types of water treatment should be considered for systems that use stainless steel water vessels, components, piping/tubing, and/or fittings. Where a chlorine type of water treatment is utilized, consideration should be given to the combined effect of chlorine concentration, duration of exposure, temperature, and pressure on stainless steel components. Stress corrosion cracking (SCC) could lead to failure of stainless steel water vessels, components, piping/tubing, or fittings. Chlorine and chlorides appear to be factors associated with stress corrosion cracking of stainless steel.

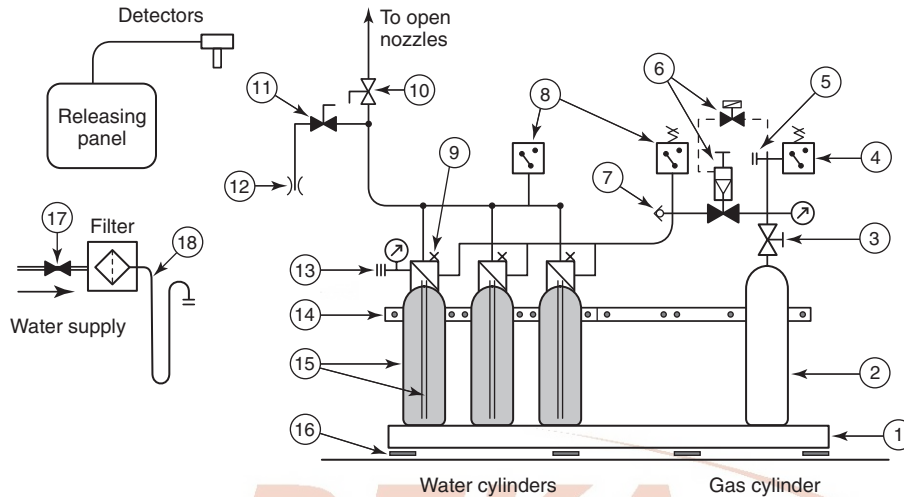
The potential growth of legionella bacteria in stored water supplies is a significant concern where water mist systems are utilized in public spaces. Measures to prevent such growth include the use of ultraviolet light inserts in the reservoir that continuously circulate water. Stored water supplies should be tested for legionella bacteria at the semi-annual and annual maintenance intervals.

**A.10.5.5** It is the intention of this subsection to require a fire department connection wherever it would be of benefit.

Paragraph 10.5.5.4(1) provides for local area protection where the fire department could effectively respond with small hose streams or portable fire extinguishers. Paragraph 10.5.5.4(2) provides for systems where the pressures available from fire department pumpers would not be adequate to supply the water

mist system. Paragraph 10.5.5.4(3) exempts systems where the atomizing medium is essential for fire suppression and water alone would be of no benefit.

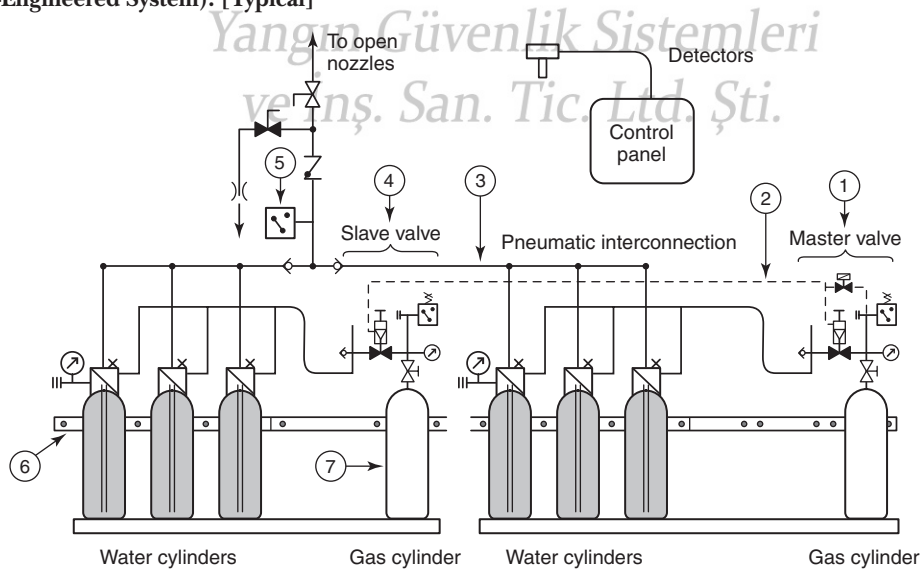
**A.11.1.6** See Figure A.11.1.6(a) through Figure A.11.1.6(i).



**Legend**

- |   |  |  |
|---|--|--|
| 1. Steel base and frame                         | 8. Pressure switches, alarm if system trips  | 14. Cylinder rack with restraints                              |
| 2. Compressed gas cylinder (driving medium)     | 9. Vent port, for filling water cylinders (fill until water discharges from open port) | 15. Pressure-rated water cylinders with dip tube               |
| 3. Cylinder control valve                       | 10. Primary system or sectional control valve  | 16. Optional load cells  |
| 4. Pressure switch, supervise cylinder pressure | 11. Test connection and drain  | 17. Water supply valve, normally closed                        |
| 5. Burst disc                                   | 12. Test orifice (alternative to full discharge)                                       | 18. Filter and hose with adaptor fitting for filling cylinders |
| 6. Solenoid operated master release valve       | 13. Cylinder discharge header with filling port  |  |
| 7. Microleakage valve                           |  |  |

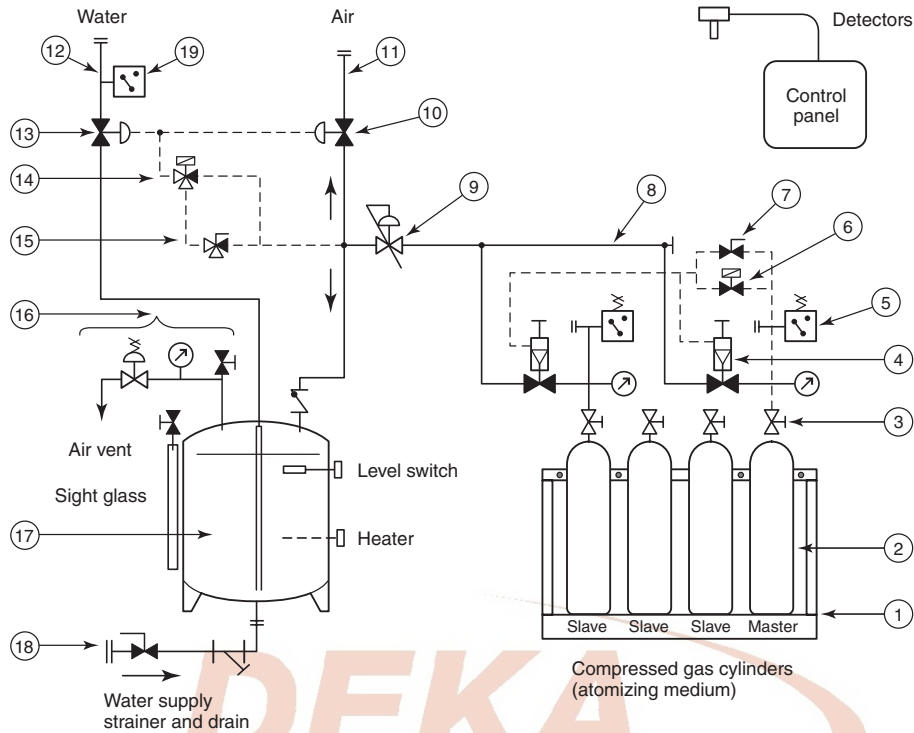
**FIGURE A.11.1.6(a) Schematic Representation of a High Pressure, Gas-Driven System with Stored Water (Pre-Engineered System). [Typical]**



**Legend**

- |   |  |  |
|---|--|--|
| 1. Solenoid operated master release valve (with local manual release) | 3. Discharge header  | 5. Pressure switch, alarm when system trips  |
| 2. Pneumatic tubing interconnecting "master" valve to "slave" valve   | 4. Pneumatically activated slave valve (no local manual release) | 6. Cylinder rack with restraints             |
|   |  | 7. Compressed gas cylinders (driving medium) |

**FIGURE A.11.1.6(b) Schematic Representation of a High Pressure, Gas-Driven System with Multiple Accumulator Units for Extended Duration. [Typical]**

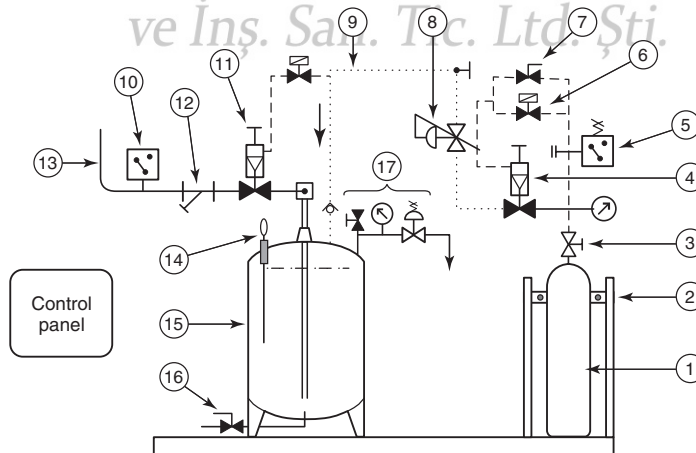


No reproduction or networking permitted without license from IHS

#### Legend

- |  |  |   |
|--|--|---|
| 1. Steel base and frame                        | 9. Air pressure control valve (high to low pressure)                       | 15. Manual release valve (opens globe valves)             |
| 2. Compressed gas cylinders (atomizing medium) | 10. Air-actuated globe valve (cycle air line)                              | 16. Pressure gauge, pressure relief valve, and vent valve |
| 3. Cylinder control valve                      | 11. Air line to twin-fluid nozzles (low pressure)                          | 17. Low pressure rated water tank                         |
| 4. Pneumatic cylinder release valve            | 12. Water line to twin-fluid nozzles (low pressure)                        | 18. Drain and refill connection and strainer              |
| 5. Pressure supervisory switch with burst disc | 13. Air-actuated globe valve (cycle water line)                            | 19. Pressure switch, alarm on discharge                   |
| 6. Solenoid operated master release valve      | 14. Low pressure solenoid valves (for operating air-actuated globe valves) |   |
| 7. Manually operated master relief valve       |  |   |
| 8. ½ in. high pressure tubing manifold         |  |   |

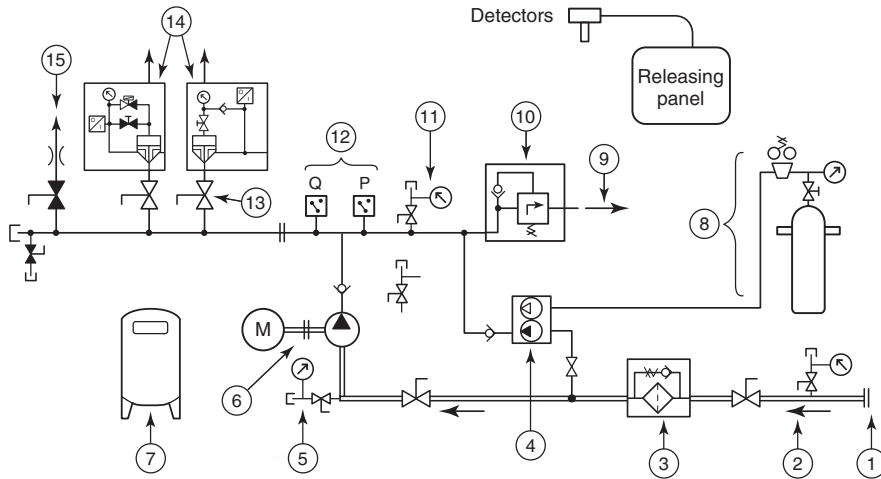
FIGURE A.11.1.6(c) Schematic Representation of a Low Pressure Twin-Fluid Water Mist System. [Typical]



#### Legend

- |   |   |   |
|---|---|---|
| 1. Compressed gas cylinder                | 7. Manually operated master release valve | 13. Water line to nozzles                                 |
| 2. Steel frame and cylinder restraints    | 8. Pressure regulating valve, high to low | 14. Water level indicator (dipstick)                      |
| 3. Cylinder control valve                 | 9. Air-line tubing                        | 15. Pressure rated water storage tank (30 bar)            |
| 4. Pneumatic cylinder release valve       | 10. Pressure switch, alarm on discharge   | 16. Drain and refill connection with strainer             |
| 5. Pressure switch disc with burst disc   | 11. Primary system control valve          | 17. Pressure gauge, pressure relief valve, and vent valve |
| 6. Solenoid operated master release valve | 12. Strainer on discharge valve           |   |

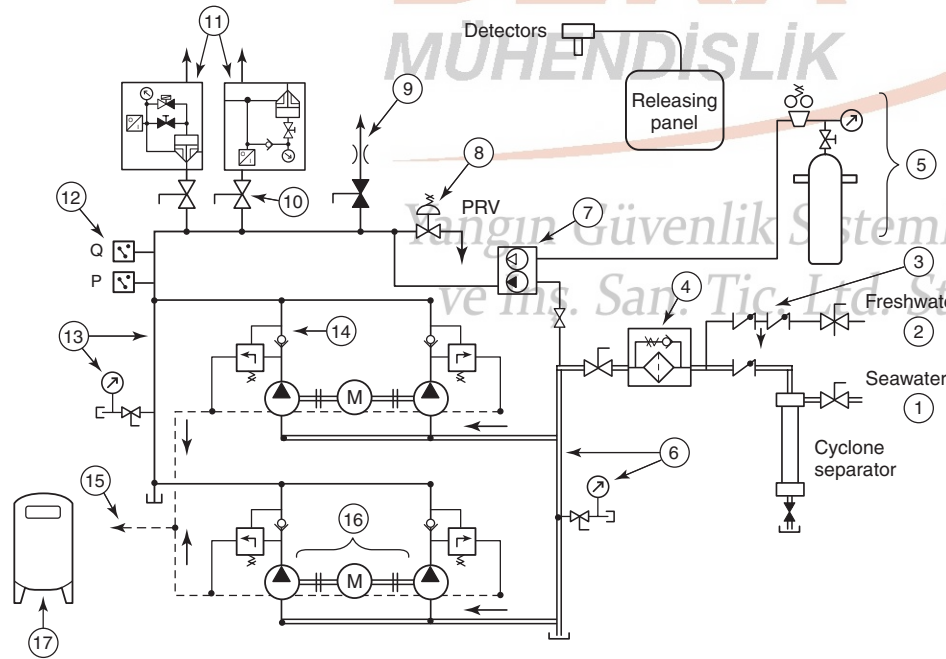
FIGURE A.11.1.6(d) Schematic Representation of a Single-Fluid Water Mist System. [Typical]



**Legend**

- |  |   |  |
|--|---|--|
| 1. Connection to water supply                                | 7. Pump controller  | 11. Pressure gauge   |
| 2. Low pressure gauge  | 8. Air supply and regulator for pneumatic pressure maintenance pump (4), includes plant air and compressors | 12. Pressure (P) and flow (Q) switches/transmitters connected to pump assembly |
| 3. Filters or screens with bypass                            | 9. Unloader valve discharge line to drain or break tank   | 13. Manual isolation valve   |
| 4. Standby pressure maintenance pump (pneumatic or electric) | 10. Unloader valve rated for 100% of pump flow capacity   | 14. Sectional control valves to mist systems (solenoid release)                |
| 5. NPSH gauge (+/-)  |   | 15. Test connection with flow meter  |
| 6. Pump and driver (electric or diesel)                      |   |  |

**FIGURE A.11.1.6(e) Schematic Diagram of a Pump-Driven Water Mist System. [Typical]**



**Legend**

- |  |   |   |
|--|---|---|
| 1. Seawater supply with cyclone separator  | 7. Pneumatic standby pressure pump  | 13. Discharge manifold with pressure gauge                        |
| 2. Freshwater supply   | 8. Pressure relief valve (optional)   | 14. Unloader valve (one per pump)                                 |
| 3. Backflow device (optional)  | 9. Test connection with flow meter  | 15. Unloader valve discharge bypass line (to drain or break tank) |
| 4. Filters or screens with bypass  | 10. Isolation valve for sectional valves                                    | 16. Positive displacement pumps (two per motor)                   |
| 5. Air supply and regulator for standby pressure maintenance pump, plant air or compressor | 11. Solenoid actuated sectional control valves                              | 17. Pump controller   |
| 6. Suction manifold with NPSH gauge (+/-)  | 12. Pressure (P) and flow (Q) switches/transmitters connected to controller |   |

**FIGURE A.11.1.6(f) Schematic Representation of a Positive Displacement Pump Assembly with Unloader Valves on Each Pump and Pressure Relief Valve on Discharge Manifold. [Typical]**

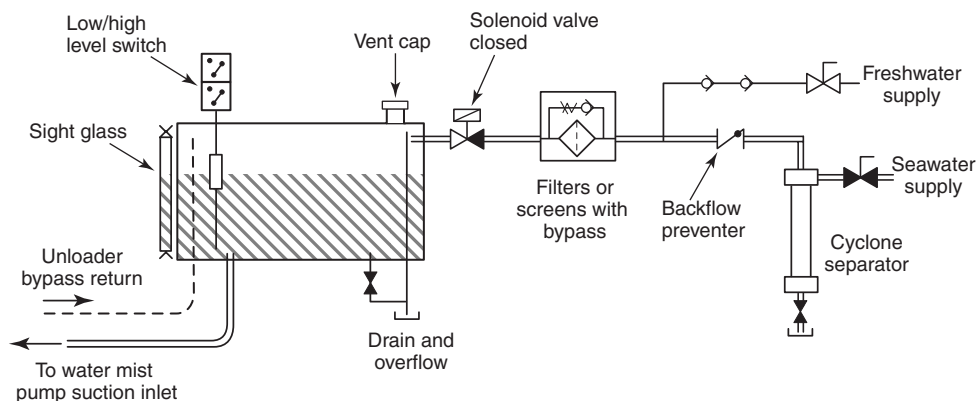


FIGURE A.11.1.6(g) Schematic Diagram of a “Break Tank” Connection in Supply to Positive Displacement Pumps (Marine Systems). [Typical]

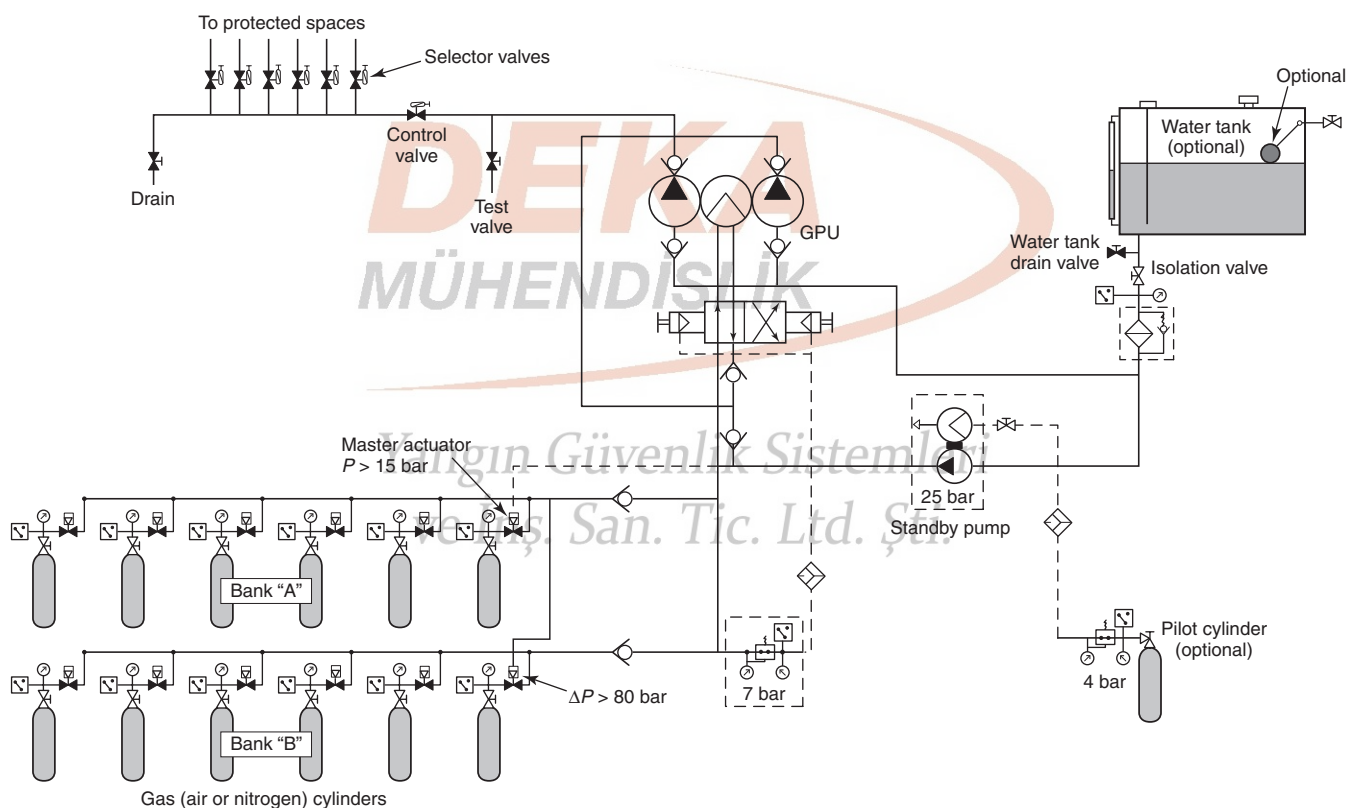


FIGURE A.11.1.6(h) Gas Pump Unit for Machinery Spaces and Gas Turbine Enclosures. [Typical]

**A.11.2** There are significant differences between how centrifugal fire pumps and positive displacement (PD) pumps operate. Methods for properly sizing centrifugal fire pumps in relation to the piping system and the design flow rate are well established in fire protection design practice. Fire protection systems designers are less familiar with PD pumps, however. The following discussion reviews some of the factors that are involved in selecting and sizing positive displacement pumps.

For constant-speed drivers, the discharge rate of a PD pump is constant. Water mist systems, however, can have a

variable demand flow, depending on how many nozzles open. The problem of using a constant discharge pump on a variable demand piping system is resolved by combining the positive displacement pump with an “unloader” valve and treating it as a composite unit. An unloader valve opens at a pre-set pressure and allows the unused portion of the pump discharge to bypass the distribution system. By including the unloader function, the PD pump “curve” can be plotted as a horizontal line, similar to a centrifugal pump curve.

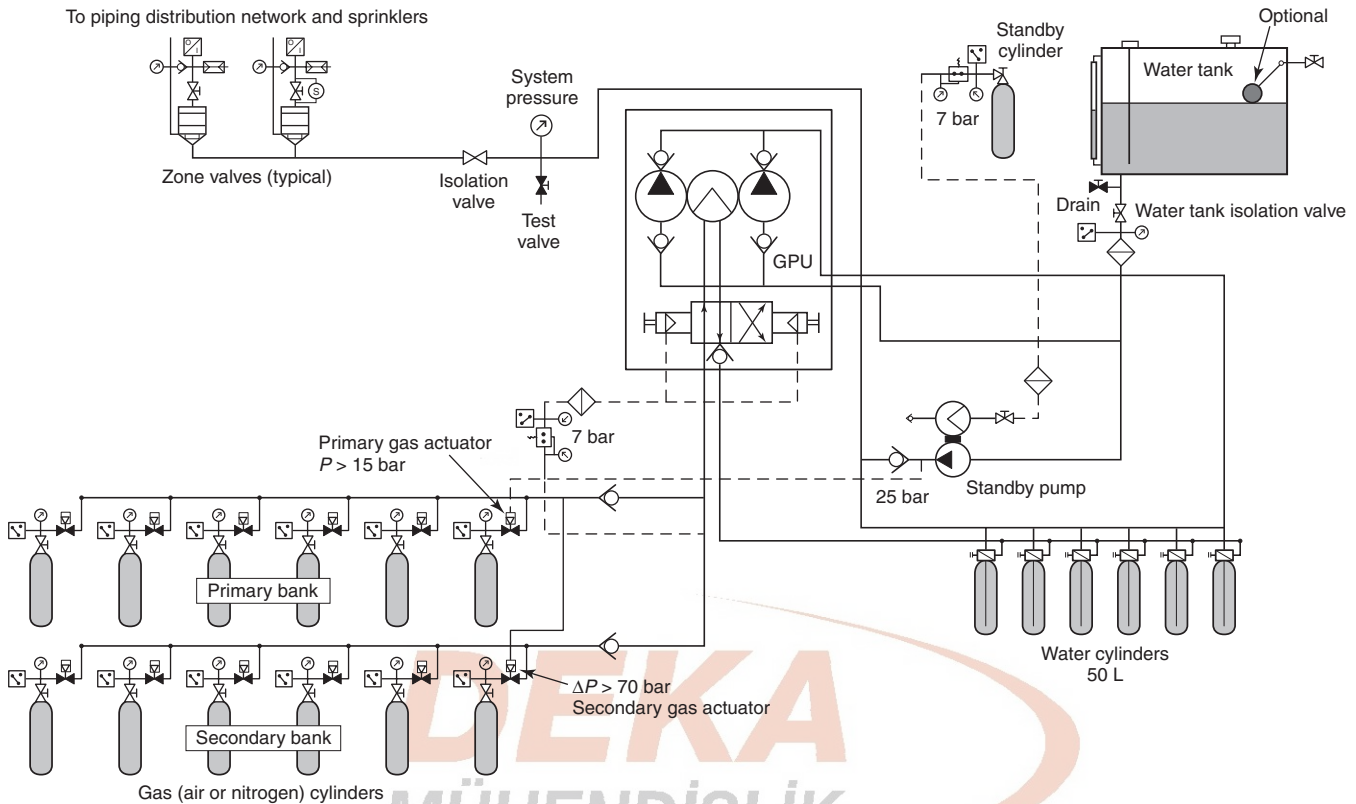


FIGURE A.11.1.6(i) Gas Pump for Light Hazard Applications. [Typical]

Important points to consider when selecting positive displacement pumps for a water mist system include the following:

- (1) The system head curve(s) (SHCs) for the water mist system under different nozzle-open arrangements must be calculated and plotted with the PD pump curve.
- (2) The actual discharge from the system is determined by the intersection of the SHC and the pump supply curve (i.e., the operating point). The operating point always has to be greater than the theoretical demand that is calculated for a system. The hydraulic calculations documentation should include a plot showing the SHCs, the pump supply curve (or line), the calculated demand point, and the operating point for each condition.
- (3) In sizing the suction supply to the pump, and in calculating the total water storage required for a given duration of protection, the flow rate at the operating point has to be used, not the theoretical or calculated design flow rate.

**A.12.2** All tests should be made by the contractor in the presence of an authorized inspector. When an inspector is not available, tests can be permitted to be witnessed by the owner or owner's representative.

Before asking for final approval of the protective equipment, installing companies should furnish a written statement to the effect that the work covered by its contract has been completed, and all specified flushing of underground, lead-in,

and system piping has been completed, successfully, together with specified hydrostatic pressure tests.

**A.12.2.3** An allowance for a small drop in gauge pressure should be made to take into consideration the total volume of the system and environmental conditions. Smaller systems could see a slight drop in gauge pressure as a result of microscopic leaks that would not affect larger systems. Large systems could be affected by temperature changes that could raise or lower the hydrostatic pressure by small amounts.

**A.12.2.3** The following caution should be heeded:

**CAUTION:** Pneumatic pressure testing creates a potential risk of injury to personnel in the area as a result of airborne projectiles if rupture of the piping system occurs. Prior to the pneumatic pressure test being conducted, the area should be evacuated and appropriate safeguards should be provided for test personnel.

**A.12.2.4.2.12** Proper shielding and grounding is particularly important if ac and dc wiring are combined in a common conduit or raceway.

**A.13.2.2** Table A.13.2.2 indicates the recommended frequencies of inspection of typical components of water mist systems. See NFPA 25, *Standard for the Inspection, Testing, and Maintenance of Water-Based Fire Protection Systems*, for comprehensive requirements for inspection, testing, and maintenance of water mist systems.

Table A.13.2.2 Maintenance of Water Mist Systems

| Item                                   | Task   | Weekly | Monthly | Quarterly | Semi-Annually  | Annually | Other           |
|--|--|--------|---------|-----------|----------------|----------|-----------------|
| Water supply (general)                 | Check source pressure.   |        |         | X         |                |          |                 |
|  | Check source quality.  |        |         |           | X (first year) | X        |                 |
|  | Test source pressure, flow, quantity, duration.                            |        |         |           |                | X        |                 |
| Water storage tanks                    | Check water level (unsupervised).  | X      |         |           |                |          |                 |
|  | Check water level (supervised).  |        |         | X         |                |          |                 |
|  | Check sight glass valves are open.   |        | X       |           |                |          |                 |
|  | Check tank gauges, pressure.   |        |         | X         |                |          |                 |
|  | Check all valves, appurtenances.   |        |         |           | X              |          |                 |
|  | Drain tank, inspect interior, and refill.                                  |        |         |           |                |          | X               |
|  | Inspect tank condition (corrosion).  |        |         |           |                |          | X               |
| Check water quality.                   |  |        |         |           |                | X        |                 |
|  | Check water temperature.   |        |         |           |                |          | Extreme weather |
| Water storage cylinder (high pressure) | Check water level (load cells).  |        |         |           | X              |          |                 |
|  | Check water level (unsupervised).  |        |         | X         |                |          |                 |
|  | Check support frame/restraints.  |        |         |           |                |          | X               |
|  | Check vent plugs at refilling.   |        |         |           |                |          | X               |
|  | Check cylinder pressure on discharge.                                      |        |         |           |                |          | X               |
|  | Inspect filters on refill connection.                                      |        |         |           |                |          | X               |
| Additive storage cylinders             | Inspect general condition, corrosion.                                      |        |         | X         |                |          |                 |
|  | Check quantity of additive agent.  |        |         |           | X              |          |                 |
|  | Test quality of additive agent.  |        |         |           |                |          | X               |
|  | Test additive injection, full discharge test.                              |        |         |           |                |          | X               |
| Water recirculation tank               | Check water level (unsupervised).  |        | X       |           |                |          |                 |
|  | Check water level (supervised).  |        |         | X         |                |          |                 |
|  | Inspect supports, attachments.   |        |         |           |                |          | X               |
|  | Test low water level alarm.  |        |         |           |                |          | X               |
|  | Check water quality, drain, flush and refill.                              |        |         |           |                |          | X               |
|  | Test operation of float operated valve.                                    |        |         |           |                |          | X               |
|  | Test pressure at outlet during discharge.                                  |        |         |           |                |          | X               |
|  | Test backflow prevention device (if present).                              |        |         |           |                |          | X               |
|  | Inspect and clean filters, strainers, cyclone separator.                   |        |         |           |                |          | X               |
| Compressed gas cylinders               | Inspect support frame and cylinder restraints.                             |        |         | X         |                |          |                 |
|  | Check cylinder pressure (unsupervised).                                    |        | X       |           |                |          |                 |
|  | Check cylinder pressure (supervised).                                      |        |         | X         |                |          |                 |
|  | Check cylinder control valve is open.                                      |        | X       |           |                |          |                 |
|  | Check cylinder capacity and pressure rating.                               |        |         |           |                |          | X               |
|  | Check cylinder compliance specification.                                   |        |         |           |                |          | X               |
|  | Confirm compressed gas meets specifications (moisture, cylinder pressure). |        |         |           |                |          | X               |
|  | Hydrostatic test cylinders.  |        |         |           |                |          | 5-12 years      |
| Plant air, compressors, and receivers  | Check air pressure (unsupervised).   | X      |         |           |                |          |                 |
|  | Check air pressure (supervised).   |        | X       |           |                |          |                 |
|  | Start compressor.  | X      |         |           |                |          |                 |
|  | Check compressor/receiver capacity, changes.                               |        |         |           | X              |          |                 |
|  | Check compressed air moisture content.                                     |        |         |           |                | X        |                 |
|  | Clean filters, moisture traps.   |        |         |           |                |          | X               |
|  | Test full capacity, duration, and any changes in other demands.            |        |         |           |                |          | X               |

(continues)



Table A.13.2.2 *Continued*

| Item                                 | Task  | Weekly | Monthly | Quarterly | Semi-Annually | Annually | Other           |
|--------------------------------------|---|--------|---------|-----------|---------------|----------|-----------------|
| Pumps and drivers                    | Inspection, testing, and maintenance shall be in accordance with the requirements of NFPA 20, <i>Standard for the Installation of Stationary Pumps for Fire Protection</i> , and NFPA 25, <i>Standard for the Inspection, Testing, and Maintenance of Water-Based Fire Protection Systems</i> . | X      | X       | X         | X             | X        |                 |
| Standby pump                         | Inspect moisture trap, oil injection (pneumatic).   |        |         | X         |               |          |                 |
|                                      | Check compressed gas supply, inlet air pressure.  |        | X       |           |               |          |                 |
|                                      | Check outlet water (standby) pressure.  |        | X       |           |               |          |                 |
|                                      | Test start/stop pressure settings for standby pressure.   |        |         | X         |               |          |                 |
| Pneumatic valves                     | Check cylinder valves, master release valves.   |        | X       |           |               |          |                 |
|                                      | Inspect all tubing associated with release valves.  |        |         | X         |               |          |                 |
|                                      | Test solenoid release of master release valve.  |        |         |           |               |          | X               |
|                                      | Test manual release of master release valve.  |        |         |           |               |          | X               |
|                                      | Test operation of slave valves.   |        |         |           |               |          | X               |
|                                      | Reset all pneumatic cylinder release valves.  |        |         |           |               |          | X               |
| System control valves                | Test on-off cycling of valves intended to cycle.  |        |         |           |               |          | X               |
|                                      | Inspection, testing, and maintenance shall be in accordance with the requirements of NFPA 25, <i>Standard for the Inspection, Testing, and Maintenance of Water-Based Fire Protection Systems</i> .   | X      | X       | X         | X             | X        |                 |
| Control equipment                    | Inspection, testing, and maintenance shall be in accordance with the requirements of NFPA 72, <i>National Fire Alarm and Signaling Code</i> .   |        |         |           |               |          |                 |
| Water mist system piping and nozzles | Inspection, testing, and maintenance shall be in accordance with NFPA 25, <i>Standard for the Inspection, Testing, and Maintenance of Water-Based Fire Protection Systems</i> .   | X      | X       | X         | X             | X        |                 |
|                                      | Inspect sample of nozzle screens and strainers (see 10.5.1.4).  |        |         |           |               |          | After discharge |
| Enclosure features, interlocks       | Inspect enclosure integrity.  |        |         |           | X             |          |                 |
| Ventilation                          | Test interlocked systems (e.g., ventilation shutdown).  |        |         |           |               |          | X               |
|                                      | Test shutdown of fuel/lubrication systems.  |        |         |           |               |          | X               |

**A.13.2.3** If differences indicate a significant change or deterioration in performance, appropriate maintenance actions should be taken to restore the component or system to its original performance.

**A.13.3.10** The representative sample should include 10 percent of the water mist nozzles in the activated zone. If contamination of filters or strainers is found on inspection, it is recommended that all nozzles within the activated zone be inspected.

**A.14.1.2** Reference is made to standards developed by the International Maritime Organization.

**A.14.1.5** Refer to ASTM F 1547, *Standard Guide Listing Relevant Standards and Publications for Commercial Shipbuilding*, and ANSI/ASME B31.1, *Power Piping Code*.

**A.14.1.6** Consideration should be given to physically separating the pumping units. It is recommended that not less than 40 percent of the maximum system's flow demand be provided from any single pumping location. Consideration should be given to using designs incorporating looped systems or arrangements that allow a section to be taken out of service for maintenance. When pumps from another onboard fire protection system, such as fire main pumps, are used to satisfy this requirement, they should be sized to simultaneously supply both systems.

**A.14.1.8** When applying NVIC 9-97, *Guide to Structural Fire Protection*, copper pipe is not considered heat sensitive; however, brazed joints are. Therefore, there are limitations on the proximity of brazed joints to deck and bulkhead penetrations. In general, brazed joints should be 300 mm or more from the penetration.

**A.14.1.9.4** A representative arrangement of the shore connections is shown in Figure A.17.7.3.12.2(1) of NFPA 13, *Standard for the Installation of Sprinkler Systems*. The international shore connection dimensions are shown in Figure A.17.1.3(4) of NFPA 13.

**A.14.1.10** The preferred arrangement for pump flow measurement is given in Figure A.17.7.3.13 of NFPA 13.

**A.14.2.2** The charge of air or gas for the hydropneumatic tank should be such that the last gallon of water in the tank leaves the tank at the system demand pressure. The tank can be arranged with an internal charge of gas or an external gas supply with a regulator. If an internal charge of air or gas is provided, the equation  $P_1 V_1 = P_2 V_2$  should be used to calculate the required gas pressure. In all cases, arrangements should be provided to avoid filling the system piping with gas when the hydropneumatic tank is empty. Under normal circumstances, the pump should be arranged to provide water at a pressure greater than the gas pressure before the tank is empty. The reference to SOLAS requires an arrangement to prevent seawater from entering the hydropneumatic tank.

**A.14.2.3** An example of an acceptable arrangement is manual operation of a sea chest valve (outside the protected space) to allow continued operation using seawater following the 30-minute stored freshwater operation.

**A.14.2.7** Deluge or antifreeze systems could be needed where protected areas are subject to freezing. Piping subject to freezing could be subject to clogging by ice.

**A.14.2.14** If combustibles are present such that they constitute a threat, the space should be protected. One example

would be the presence of large bundles of exposed computer or electrical cable.

Typical amounts of lighting or control cabling should not be considered to constitute a fire threat.

**A.14.3.2.1** Designers should take into account the flash points of all stored liquids when planning a system. Water mist systems protecting flammable liquid lockers storing liquids with a flash point below the ambient water temperature could experience a flammable vapor explosion if the water mist system does not fully extinguish the fire.

**A.14.3.3** It is assumed that water mist systems for flammable liquid hazards and compartments require the simultaneous release of water mist from all nozzles in groups of nozzles in the manner of total flooding systems. If systems that operate using individually, thermally actuated nozzles are shown by test to have the capability of extinguishing the variety of fires of the machinery space fire test protocol, then manual actuation should cause sufficient nozzles to operate to achieve protection no less effective than that demonstrated in the test protocol.

**A.14.3.3.2** An example of an acceptable arrangement is manual operation of a sea chest valve (outside the protected space) to allow continued operation on seawater following the 30-minute stored freshwater discharge.

**A.14.3.4** Time delays are optional on water mist systems.

**A.14.3.5.6** For systems that cycle, the 15-minute requirement represents 15 minutes at the maximum flow rate, as if the duty cycle were 100 percent for 15 minutes.

Examples include the following:

- (1) *Constant* — such as supplied by a pump
- (2) *Decaying* — occurs when a pressure cylinder discharges
- (3) *Uniform cycling* — when a timing device is used to periodically change the pressure or the flow rate
- (4) *Nonuniform cycling* — such as when a heat detector cycles a system on and off

**A.14.3.5.7** Following the depletion of the 30-minute freshwater supply, if continuous seawater operation is provided at a pressure other than that used to successfully perform the machinery space fire tests of 14.3.2.1, the nozzle spray characteristics should be capable of maintaining the cooling of the compartment. Flow rates need not equal those of Safety of Life at Sea (SOLAS) Resolution 10, *Fixed Pressure Water Spray Systems*.

**A.14.3.6** It is recommended that on passenger ships designed to carry more than 36 persons and on all tank vessels, both the main and emergency sources of power should be from outside the protected space.

**A.14.4** The ship's crew will be called upon to inspect, test, maintain, react to, and use some or all parts of the water mist fire suppression system. Therefore, the crew is an integral part of the system. Historically, the crew is the part of the system that system designers and installers have little or no control over. Much of the system will be designed to maintain readiness and operate without human intervention. However, system readiness and operation during an emergency will always involve human interaction with the system. Systems should include design and component features incorporating human factors so as to maximize readiness and utility during a fire.

**A.14.5** Examples of water mist system design features unique to combatant vessels are as follows:

- (1) Extended-duration water supply
- (2) Dedicated freshwater storage tanks
- (3) Dual-source water supply for combat redundancy
- (4) Enhanced shock and vibration resistance
- (5) Dual system activation means
- (6) Corrosion resistance
- (7) Two-source power supply with automatic bus transfer feed
- (8) Combat survivability features
- (9) Increased structural integrity for piping valves, fittings, and hangers
- (10) Redundancy and separation of controls and valves
- (11) Augmentation with foam bilge sprinklering
- (12) Full-flow end-of-line test fittings
- (13) Ventilation interlock
- (14) Remote tank-level monitoring

### Annex B Research Summary

*This annex is not a part of the recommendations of this NFPA document but is included for informational purposes only.*

**B.1 Water Mist Droplet Size Characterization and Measurement.** A key mechanism in the successful use of water mist fire protection systems is the increased surface area per unit water volume afforded with the generation and application of small droplets. The increased surface area dramatically increases the rate of heat transfer from the fire to the water mist droplet, cooling the combustion reaction and diluting the oxygen concentration with the generation of water vapor in the vicinity of the fire. It is important to characterize the droplet size distribution produced in listed nozzles for use in the future design and application of water mist systems. It will be valuable in assessing the ability of water mist droplets to control, suppress, and extinguish fires of all types and sizes.

Presently, three basic techniques are used for the characterization of droplet sizes in a nozzle spray: optical imaging; diffraction; and Doppler refraction. The first technique uses optical technology to photograph or electronically image the droplets in a small volume of the mist. The image is then analyzed to determine the size distribution of droplets on the image.

The second technique uses a collimated light source passed through the water mist. The water droplets diffract the light into a series of detectors. The angle of diffraction is a function of the size of the droplets in the light beam. By measuring the relative light intensities on the detectors, the distribution of droplet sizes can be determined.

The third technique uses a pair of crossed laser beams to generate a small sample volume through which the water droplets pass. The laser light is refracted inside the droplets and detected off-axis. The detector signal is processed to define the droplet size and velocity distributions.

All three techniques are automated in most commercially available measuring instruments, sampling tens of thousands of droplets for the determination of a droplet size distribution. The instruments typically divide the sizes into categories, or “bins,” defined by a range of diameters assigned to each bin. Results are then reported as the number of droplets in each bin or as a fractional distribution of number count or total volume in each bin.

Most commercially available measuring instruments also present additional measurements of size distribution significant to the characterization of a water mist. One of these is the Sauter Mean Diameter (SMD), defined as the total volume of

the measured droplet population divided by the total surface area of the population. SMD is often used as a characteristic dimension when mass transfer (including phase change) is the key process.

Another important measurement is the maximum diameter at which a specified fraction of the total volume is accumulated. For example,  $Dv_{0.10}$  represents the diameter at which 10 percent of the total volume of the water mist is contained in droplets at or less than the specified diameter. By this definition,  $Dv_{0.10}$  represents the volumetric median diameter; that is, 50 percent of the total volume of the total water mist is contained in droplets equal to or less than this diameter, and 50 percent is contained in droplets of greater diameter.

### Annex C Examples of Fire Test Protocols

*This annex is not a part of the recommendations of this NFPA document but is included for informational purposes only.*

**C.1 General.** In the absence of a generalized design method based on engineering first principles, water mist systems must be listed for specific hazards and protection objectives. It is the intent of NFPA 750 that such listings be obtained through full-scale fire tests and system component evaluations conducted by internationally recognized laboratories to demonstrate that performance objectives can be met. New potential applications of water mist arise continuously, for which ad hoc test procedures have been developed. Only a limited number of such ad hoc fire test protocols meet the intent of this standard, which is as follows:

- (1) Test protocols should be based on a fire protection engineering evaluation of the fire hazard, the compartment conditions, and the performance objectives for the system.
- (2) Test protocols should be developed, carried out, and interpreted by internationally recognized fire testing laboratories.

Only test protocols developed in that manner are recognized as the basis of a listing. The full listing consists of an approval report describing the results of the performance-based fire testing and the component evaluations, and a manufacturer’s design installation and maintenance manual. The nozzle characteristics; spacing between nozzles; distances from ceilings, walls, or obstructions; minimum operating pressures; and water supply requirements are all established by the approval report.

**C.1.1** Testing and certification laboratories should extend their system evaluation to components other than the nozzle, based on a customized evaluation or review. Where such evaluations are done, details of the evaluation criteria should be included in the approval report. It is the intent of NFPA 750 that all components not included in the approval report be listed or approved equipment. However, some types of equipment utilized in water mist systems but not fully evaluated in the approval process are new to fire protection applications and no prior listings exist. An example includes the piston-type pumps used in high pressure systems. Such gaps in the approval process are gradually being addressed through changes to other standards (such as NFPA 20, *Standard for the Installation of Stationary Pumps for Fire Protection*, 2003 edition) and by case-by-case evaluations conducted by a recognized testing laboratory.

**C.1.2** Table C.1.2 identifies several organizations with wide international recognition that currently develop or administer test protocols for water mist fire suppression systems. The following sections provide brief descriptions of the scope of application and the acceptance criteria of the test protocols that are the basis for the 1998 listings for water mist systems. The testing laboratories can add or subtract certain fire tests, at their discretion, based on their interpretation of the system performance limits. The reader should refer to the original test protocols for complete test details.

## C.2 International Maritime Organization Protocols.

**C.2.1** The International Maritime Organization does not conduct fire tests but is the body responsible for the development of guidelines that contain fire test protocols intended to ensure that water mist systems provide protection “equivalent to” conventional sprinkler and water spray systems on ships. There are three circulars of interest. MSC/Circ. A.800 (19) *Revised Guidelines for Approval of Sprinkler Systems* has been developed for water mist systems installed in accommodation and

**Table C.1.2 Internationally Recognized Agencies with Published Fire Test Protocols for Water Mist Fire Protection Systems**

| Agency   | Water Mist Fire Test Protocol  |
|--|--|
| 1. International Maritime Organization, London, England  | <p>IMO MSC/Circ. 668, <i>Alternative Arrangements for Halon Fire-Extinguishing Systems in Machinery Spaces and Pump-Rooms</i>.</p> <p>(a) Appendix A, “Component Manufacturing Standards of Equivalent Water-Based Fire Extinguishing Systems,” 1994.</p> <p>(b) Appendix B, “Interim Test Method for Fire Testing Equivalent Water-Based Fire-Extinguishing Systems for Machinery Spaces of Category A and Cargo Pump-Rooms,” 1994.</p> <p>As amended in MSC/Circ. 728, <i>Amendments to the Test Method for Equivalent Water-Based Fire-Extinguishing Systems for Machinery Spaces of Category A and Cargo Pump-Rooms Contained in MSC/Circ. 668</i>, Appendix B, June 1996.</p> <p>IMO Res. A.800 (19), <i>Revised Guidelines for Approval of Sprinkler Systems</i>, Equivalent to that referred to in SOLAS Regulations II-2/12.</p> <p>(a) Appendix 1, “Component Manufacturing Standards for Water Mist Nozzles.”</p> <p>(b) Appendix 2, “Fire Test Procedures for Equivalent Sprinkler Systems in Accommodation, Public Space and Service Areas on Passenger Ships,” December 1995.</p>   |
| 2. Factory Mutual Research Corporation, Norwood, MA, USA | <p>(a) FMRC <i>Draft Performance Requirements for Fine Water Spray Systems for the Protection of Combustion Turbine Enclosures, Machinery Spaces, and Special Hazard Machinery Spaces with Volumes Not Exceeding 2825 ft<sup>3</sup> (80 m<sup>3</sup>)</i>.</p> <p>(b) FMRC <i>Draft Performance Requirements for Fine Water Spray Systems for the Protection of Combustion Turbine Enclosures, Machinery Spaces, and Special Hazard Machinery Spaces with Volumes Not Exceeding 9175 ft<sup>3</sup> (260 m<sup>3</sup>)</i>.</p> <p>(c) FMRC <i>Draft Performance Requirements for Fine Water Spray Systems for the Protection of Combustion Turbine Enclosures, Machinery Spaces, and Special Hazard Machinery Spaces with Volumes Exceeding 9175 ft<sup>3</sup> (260 m<sup>3</sup>)</i>.</p> <p>(d) FMRC <i>Draft Performance Requirements for Fine Water Spray Systems for the Protection of Light Hazard Occupancies</i>.</p> <p>(e) FMRC <i>Draft Performance Requirements for Fine Water Spray Systems for the Protection of Wet Benches and Other Processing Equipment</i>.</p> <p>(f) FMRC <i>Draft Performance Requirements for Water Mist Systems for Local Application System Protection</i>.</p> |
| 3. Underwriters Laboratories Inc., Northbrook, IL, USA   | <p>ANSI/UL 2167, <i>Standard for Water Mist Nozzles for Fire Protection Service</i>.</p> <p>(a) Machinery Spaces</p> <p>(b) Passenger Cabin Fire Tests</p> <p>(c) Passenger Cabins Greater Than 12 m<sup>2</sup></p> <p>(d) Public Space Fire Tests</p> <p>(e) Residential Area Fire Tests</p> <p>(f) Light Hazard Area Fire Test</p> <p>(g) Ordinary Hazard I and II Tests</p> <p>(h) Nozzle Construction Design, Marking and Performance Requirements</p>  |
| 4. Verband der Schadenversichen eV (VDS), Germany        | <p>VDS 2498, <i>Guidelines for Water Extinguishing Systems Requirements and Test Methods for Fine Spray Nozzles</i>, 1996 edition.</p> <p>(a) Fine Spray Nozzles for Cable Conduits</p>  |

service areas, using automatic nozzles. These systems are considered equivalent to light or ordinary hazard automatic sprinklers. MSC/Circ. 668/728 covers the use of nonautomatic water mist nozzles intended for total flooding protection of machinery spaces and pump rooms. These nozzles are considered equivalent to conventional water spray deluge systems. The third circular is MSC/Circ. 913, *Guidelines for the Approval of Fixed Water-Based Local Application Fire-Fighting Systems for Use in Category A Machinery Spaces*, which provides criteria for local application water mist systems used in machinery spaces to protect high hazard areas such as fuel manifolds or boiler fronts. (At this time, IMO Circ. 913 is still in the process of formal acceptance.)

These systems are intended for use in conjunction with another total flooding system. The actual fire tests can be conducted by any recognized fire test laboratory, such as SP (Sweden), VTT (Finland), SINTEF (Norway), or other agencies in Europe, and FM or ULI in North America. For a water mist system to be accepted by maritime authorities having jurisdiction, it has to meet the performance criteria described in the test protocols. A formal report by the testing laboratory — describing the outcome of the fire tests and certifying that the system performance met the performance limits of the test protocol — along with the evaluation of components and system hardware, constitutes the “basis” for approval of the system by marine regulatory authorities. The IMO circulars include both fire testing protocols and component testing standards for water mist nozzles.

**C.2.2** Copies of MSC/Circ. A.800 (19) and MSC/Circ. 668/728 can be obtained from the International Maritime Organization, 4 Albert Embankment, London SE1 7SR, or ordered online at [www.imo.org](http://www.imo.org). The circulars are published in the *International Code for the Application of Fire Test Procedures (FTP Code)*. This document can be found in the Marine Technology category under the publications section of the IMO website.

### C.2.3 Machinery Compartments.

**C.2.3.1** “Test Method for Equivalent Sprinkler System for Class 1, 2, and 3, Category A Machinery Compartments” addresses liquid fuel fires in machinery compartments of 500 m<sup>3</sup>, main diesel machinery in spaces up to 3000 m<sup>3</sup>, and larger volume diesel machinery spaces on oil tankers and container ships. The test compartment has a 2 m × 2 m ventilation opening in one wall. A mock-up of a large diesel engine with associated bilge space is constructed in the center of the test enclosure. Liquid fuels include low and high pressure fuel lines, lubrication oil lines, and hydraulic oil lines, with spray, spill, and pool fires. Some of the fires are shielded from direct water spray by steel plates. Thirteen fire scenarios are described: eight use commercial fuel oil or light diesel oil (“high” flash point fuels), four use heptane fuel (“low” flash point fuels), and one involves a wood crib and heptane igniter. Spray, pool, and spill fires are tested.

**C.2.3.2** The IMO machinery space water mist system has to extinguish all test fires, including small hidden bilge fires, and prevent reignition. This test protocol requires full extinguishment of all fires. Systems that have passed the IMO machinery space test protocol are permitted to utilize combinations of total flooding ceiling nozzles and screening nozzles over the ventilation opening, as well as the addition of foaming agent to the water supply (for hidden fires in the bilge areas). Systems can also incorporate a separate bilge protection system. Nozzles are generally of the nonautomatic type (open), and

the systems are permitted to be activated manually. Water supply is provided using stored water in pressurized cylinders to provide the first minute of operation without electric power. After one minute, it is assumed that pumps will be started to meet the waterflow demand for up to 30 minutes, either from stored freshwater or from seawater sources.

### C.2.4 Cabin and Corridor Fires.

**C.2.4.1 Test Protocol for Equivalent Sprinkler Systems for Cabin and Corridor Fires.** The test protocol describes fire tests involving polyether mattresses with cotton covers in sleeping quarters on ships. Compartment sizes range from 16 m<sup>2</sup> to 25 m<sup>2</sup> and up to 52 m<sup>2</sup> in luxury cabins. The luxury cabin test includes a wood crib and simulated furniture, which is the residential fuel package. Nozzles are of the automatic type (activated by heat in the manner of a sprinkler). The system is tested with cabin and corridor nozzles. In one test, cabin nozzles are disabled, and the corridor nozzles have to prevent fire from spreading along the corridor.

**C.2.4.2** It is important to note that, unlike the machinery space tests, pass/fail criteria for the cabin and corridor fires are not based on full extinguishment. The cabin and corridor fires have to be controlled by the water mist system for up to 10 minutes, after which time the test operators manually extinguish any remaining fire. The average damage to the mattresses over all tests must not exceed 35 percent, with no test resulting in losses greater than 50 percent of the original material.

### C.2.5 Water-Based Fire Extinguishing Systems in Accommodation and Public Space Areas Onboard Ships.

**C.2.5.1** The public space tests evaluate the ability of water mist to control fires in open public spaces on ships, with ceiling heights of one or two deck heights (2.5 m or 5.0 m, respectively). The open public space tests involve simulated couches with cotton-covered polyether mattresses on steel frames, representing a lounge-type setting in the center of large rooms. Tests are done under one, between two, and between four nozzles, at either 2.5 m or 5.0 m ceiling height. Nozzles are of the automatic type (thermally activated). A corner fire scenario is included, which involves fire in the corner of a room with combustible wall and ceiling panels. The water mist system has to prevent fire spread to target couches and limit ceiling temperatures. The corner test includes a disabled nozzle, such that the fire control is achieved through operation of the functioning nozzles.

**C.2.5.2** The water mist system has to control the fire for 10 minutes, after which time the operators manually extinguish any remaining fire. Damage to the mattresses has to be within prescribed limits, with the average for all tests of 35 percent or less, with no single test exceeding 50 percent damage.

**C.2.5.3** Shopping and storage areas on ships involve much higher fuel loading than encountered in open public areas. The IMO test protocol for shopping and storage areas involves plastic cups in cardboard cartons (standard Group A plastic commodity) stacked 1.5 m high in the same array as used for ordinary hazard sprinkler fire tests. Target arrays of empty cartons surround the main fuel piles.

**C.2.5.4** The fire in the stacked boxes has to be controlled for up to 10 minutes, after which time the operators manually extinguish the remaining fire. Fire cannot spread to the target boxes, nor can charring of any of the target arrays occur. In any one test, damage to the boxes and plastic cups in the fire source cartons cannot exceed 50 percent. This test fire represents a challenge to any water-based suppression systems, including conventional sprinklers.

### C.2.6 IMO Component Standards.

**C.2.6.1** IMO MSC/668, in Appendix A, “Component Manufacturing Standards of Equivalent Water-Based Fire Extinguishing Systems,” describes tests for evaluating water mist nozzles. Rigorous tests are performed on the nozzle to determine hydraulic characteristics, water flux and drop size distributions, responsiveness of thermal sensing elements (for automatic nozzles), structural strength, resistance to impact, corrosion, and clogging, and so forth. The tests described in this annex are the basis for the component evaluations conducted under UL 2167, *Standard for Water Mist Nozzles for Fire Protection Service*. Components other than the nozzle, such as water or gas storage cylinders, pump, control valves, pressure reducing valves, or special actuators, are not part of the IMO MSC/Circ. 668, Appendix A protocol.

**C.2.7 Local Application Systems for Machinery Spaces.** The appendix to MSC/Circ. 913 indicates that local application systems are intended to provide additional, localized fire suppression in areas where there is a possibility of flammable or combustible liquids contacting heated surfaces, such as the fire hazard portions of internal combustion machinery used for the ship’s main propulsion and power generation, boiler fronts, the fire hazard portions of incinerators, and purifiers for heated fuel oil within Category A machinery spaces. The system is intended as a supplement to the required total flooding system and will allow immediate, manually activated fire control without the necessity of engine shutdown, personnel evacuation, shutting down of forced ventilation fans, or the sealing of the space. In the case of periodically unattended machinery spaces, the fire-fighting system shall have both automatic and manual release capabilities.

The appendix to MSC/Circ. 913 contains the fire test protocol used to evaluate the water mist nozzles for this application. The test method verifies the design criteria for vertical and horizontal grids of nozzles. The test method is intended to evaluate maximum nozzle spacing, minimum and maximum distances from the nozzle to the hazard, the minimum nozzle flow rate, and minimum and maximum operating pressures. Component testing standards are taken from those listed in IMO MSC/Circ. 668/728. The fire tests are to be conducted in an open area of at least 100 m<sup>2</sup>. Both 1 MW and 6 MW spray fires using light diesel oil as the fuel source are included in the protocol.

### C.3 Factory Mutual Research Corporation Test Protocols.

**C.3.1 General.** Factory Mutual Research Corporation (FMRC) has developed the following test protocols, which are the basis for current listings of water mist systems and components [denoted by FMRC as Fine Water Spray (FWS) systems]:

- (1) FMRC *Draft Performance Requirements for Fine Water Spray Systems for the Protection of Combustion Turbine Enclosures, Machinery Spaces, and Special Hazard Machinery Spaces with Volumes Not Exceeding 2825 ft<sup>3</sup> (80 m<sup>3</sup>)*
- (2) FMRC *Draft Performance Requirements for Fine Water Spray Systems for the Protection of Combustion Turbine Enclosures, Machinery Spaces, and Special Hazard Machinery Spaces with Volumes Not Exceeding 9175 ft<sup>3</sup> (260 m<sup>3</sup>)*
- (3) FMRC *Draft Performance Requirements for Fine Water Spray Systems for the Protection of Combustion Turbine Enclosures, Machinery Spaces, and Special Hazard Machinery Spaces with Volumes Exceeding 9175 ft<sup>3</sup> (260 m<sup>3</sup>)*
- (4) FMRC *Draft Performance Requirements for Fine Water Spray Systems for the Protection of Light Hazard Occupancies*

- (5) FMRC *Draft Performance Requirements for Fine Water Spray Systems for the Protection of Wet Benches and Other Processing Equipment*
- (6) FMRC *Draft Performance Requirements for Water Mist Systems for Local Application System Protection*

**C.3.1.1** Note that the term *machinery space* refers to flammable liquid hazards no greater than those of diesel fuel, and the term *special hazard machinery space* refers to flammable liquid hazards no greater than those of n-heptane. These terms should not be confused with the term *machinery space* used in the International Maritime Organization (IMO) documents relating to fine water spray. They are not intended to be interchangeable.

**C.3.1.2** The standards describe fire test performance criteria and methods. Because each fine water spray system is unique in its design and use of components, the component testing of each fine water spray system is evaluated on a case-by-case basis. The components are tested for functionality, performance, integrity, and reliability. The manufacturers’ design, installation, and maintenance manual(s) are reviewed for technical content and clarity. The supplied hydraulic calculations are also reviewed.

**C.3.2 FMRC Draft Performance Requirements for Fine Water Spray Systems for the Protection of Combustion Turbine Enclosures, Machinery Spaces, and Special Hazard Machinery Spaces with Volumes Not Exceeding 2825 ft<sup>3</sup> (80 m<sup>3</sup>).**

**C.3.2.1** The objective of this standard is to ensure that the fine water spray system extinguishes spray and pool fires that can occur, for example, due to breaks in lubrication, hydraulic, or fuel lines. Typically, these fires are highly shielded. While spray fires can occur only as the result of a supply line break, pool fires can occur as a result of a breakage or as a result of a small leak over a large period of time. This standard is limited to volumes not exceeding 80 m<sup>3</sup> (2825 ft<sup>3</sup>). The FMRC standard assumes automatic interlocks for the following:

- (1) All fuel supply lines (for combustion turbines, bearing lubrication can be left on to allow the turbine to coast down)
- (2) Door closures
- (3) Ventilation shutdown
- (4) Electrical systems

**C.3.2.2** The water supply required is dependent on the application. For combustion turbines, the water supply has to be sufficient to protect the turbine for the duration of its coast downtime. For machinery spaces and special hazard machinery spaces, the protection time is 10 minutes.

**C.3.2.3** The detection is by means of heat detectors. The detection is so designed as to detect the fire and activate the fine water spray system within 60 seconds of the ignition.

**C.3.2.4** The fine water spray system has to extinguish all spray and pool fires within 5 minutes from the time of ignition. Tests are conducted in closed enclosures as well as enclosures with natural ventilation. For optional protection of insulated combustion turbines, the insulation mat can be suppressed rather than extinguished.

**C.3.2.5** In addition to the fire performance criteria, fine water spray systems used for the protection of combustion turbines cannot cause damage to the turbine by means of thermal shock or cracking of the turbine casing or induce blade rubbing. The rate of cooling of the steel test plate (1 m × 2 m × 5 cm thick) must not exceed limits set by FMRC. It can be more difficult to successfully

pass the cooling test than to pass the fire tests, and the results of the cooling test often indicate the number, type, and placement of the fine water spray nozzles.

**C.3.3 FMRC Draft Performance Requirements for Fine Water Spray Systems for the Protection of Combustion Turbine Enclosures, Machinery Spaces, and Special Hazard Machinery Spaces with Volumes Not Exceeding 9175 ft<sup>3</sup> (260 m<sup>3</sup>).**

**C.3.3.1** The objective of this standard is to ensure that the fine water spray system extinguishes spray and pool fires that can occur, for example, due to breaks in lubrication, hydraulic, or fuel lines. Typically, these fires are highly shielded. While spray fires can occur only as the result of a supply line break, pool fires can occur as a result of a breakage or as a result of a small leak over a large period of time. This standard is limited to volumes not exceeding 260 m<sup>3</sup> (9175 ft<sup>3</sup>). The FMRC standard assumes automatic interlocks for the following:

- (1) All fuel supply lines (for combustion turbine, bearing lubrication can be left on to allow the turbine to coast down)
- (2) Door closures
- (3) Ventilation shutdown
- (4) Electrical systems

**C.3.3.2** The water supply required is dependent on the application. For combustion turbines, the water supply has to be sufficient to protect the turbine for the duration of its coast downtime. For machinery spaces and special hazard machinery spaces, the protection time is 10 minutes.

**C.3.3.3** The detection is by means of heat detectors. The detection is so designed as to detect the fire and activate the fine water spray system within 60 seconds of the ignition.

**C.3.3.4** The fine water spray system has to extinguish all spray and pool fires within 5 minutes from the time of ignition. Tests are conducted in closed enclosures as well as enclosures with natural ventilation. For optional protection of insulated combustion turbines, the insulation can be suppressed rather than extinguished. In addition to demonstrating performance in volumes not exceeding 260 m<sup>3</sup> (9175 ft<sup>3</sup>), systems also have to demonstrate the capability to perform in small [130 m<sup>3</sup> (4590 ft<sup>3</sup>)] enclosures.

**C.3.3.5** In addition to the fire performance criteria, fine water spray systems used for the protection of combustion turbines cannot cause damage to the turbine by means of thermal shock, cause cracking of the turbine casing, or induce blade rubbing. The rate of cooling of the steel test plate (1 m × 2 m × 5 cm thick) cannot exceed limits set by FMRC. It can be more difficult to successfully pass the cooling test than to pass the fire tests, and the results of the cooling test often indicate the number, type, and placement of the fine water spray nozzles.

**C.3.4 FMRC Draft Performance Requirements for Fine Water Spray Systems for the Protection of Combustion Turbine Enclosures, Machinery Spaces, and Special Hazard Machinery Spaces with Volumes Exceeding 9175 ft<sup>3</sup> (260 m<sup>3</sup>).**

**C.3.4.1** The objective of this standard is to ensure that the fine water spray system extinguishes spray and pool fires that can occur, for example, due to breaks in lubrication, hydraulic, or fuel lines. Typically, these fires are highly shielded. Although spray fires can occur only as the result of a supply line break, pool fires can occur as a result of a breakage or as a result of a small leak over a large period of time. The FMRC standard assumes automatic interlocks for the following:

- (1) All fuel supply lines (for combustion turbines, bearing lubrication can be left on to allow the turbine to coast down)
- (2) Door closures

- (3) Ventilation shutdown
- (4) Electrical systems

**C.3.4.2** This standard is based on the IMO *Standard for Shipboard Machinery Spaces*, although the hazards discussed in both documents are different. Due to differences in system design and performance, extrapolation of results to larger room sizes is not permitted by FMRC at this time.

**C.3.4.3** The water supply required is dependent on the application. For combustion turbines, the water supply has to be sufficient to protect the turbine for the duration of its coast downtime. For machinery spaces and special hazard machinery spaces, the protection time is 60 minutes. Typically, the volumes tested exceed 800 m<sup>3</sup> (28,230 ft<sup>3</sup>).

**C.3.4.4** The detection is by means of heat detectors. The detection is so designed as to detect the fire and activate the fine water spray system within 60 seconds of the ignition.

**C.3.4.5** The fine water spray system has to extinguish all spray, pool, and crib fires within 30 minutes from the time of ignition. The exception is a small shielded diesel pool fire that has to be suppressed. Tests are conducted in enclosures with natural ventilation. For optional protection of insulated combustion turbines, the insulation mat can be suppressed rather than extinguished.

**C.3.4.6** In addition to the fire performance criteria, fine water spray systems used for the protection of combustion turbines cannot cause damage to the turbine by means of thermal shock or cracking of the turbine casing or induce blade rubbing. The rate of cooling of the steel test plate (1 m × 2 m × 5 cm thick) cannot exceed limits set by FMRC. It can be more difficult to successfully pass the cooling test than to pass the fire tests, and the results of the cooling test often indicate the number, type, and placement of the fine water spray nozzles.

**C.3.5 FMRC Draft Performance Requirements for Fine Water Spray Systems for the Protection of Light Hazard Occupancies.**

**C.3.5.1** The objective of this standard is to ensure that the fine water spray system controls fires typically found in light hazard occupancies and prevents the spread of the fire beyond the room or area of origin. These fires typically involve furnishings and wall coverings. This standard limits the heights of enclosed spaces to 2.4 m (8 ft) and the heights of unrestricted spaces to 5 m (16 ft 5 in.).

**C.3.5.2** This standard is based on the IMO *Standard for Shipboard Corridors, Cabins, and Public Spaces*, although the hazards discussed in both documents are different.

**C.3.5.3** The water supply required is 60 minutes for the most remote nine nozzles at the rated operating pressure.

**C.3.5.4** The detection is by means of individual heat responsive elements on the nozzles. The nozzles should meet FMRC requirements for quick response sprinklers and are limited to a maximum nominal temperature rating of 107°C (225°F). Nozzle spacing is to be uniform with uniform spacing, preferably one-half of the standard nozzle spacing, from the wall.

**C.3.5.5** The fire performance tests consist of three test areas: small compartment, large compartment, and open space.

**C.3.5.5.1** The small compartment [3 m × 4 m × 2.4 m (10 ft × 13 ft × 8 ft) high] has a door 0.8 m × 2.2 m (2 ft 6 in. × 7 ft 2 in.) high and represents a small ship cabin. The fuel package for this room consists of two bunk beds identical to the IMO specification. The purpose of this test is to delineate mist nozzles from sprinklers. The fire is ignited on the lower mattress, and the test methodology is identical to that specified in

the IMO test series. Pass/fail criteria are based on damage of the lower bunk (maximum of 40 percent), ceiling surface temperature over ignition [maximum of 260°C (500°F)], and a maximum gas temperature 76 mm (3 in.) below the ceiling of 315°C (600°F).

**C.3.5.5.2** The large compartment [having equal sides not exceeding 6 m (20 ft) and a height of 2.4 m (8 ft)] has two doors [each 0.8 m × 2.2 m (2 ft 6 in. × 7 ft 2 in.) high] located in diagonally opposite corners. A nozzle is placed in the doorway opposite the fuel package. The fuel package and test method are identical to the IMO specification. The heptane under the wood crib is ignited first, then followed 40 seconds later by the ignition of the excelsior. The doorway nozzles do not operate (indicating that the fire would not have spread to an adjacent area). Additional pass/fail criteria include ceiling surface temperature over ignition [maximum of 265°C (510°F)] and a maximum gas temperature 76 mm (3 in.) below the ceiling of 315°C (600°F).

**C.3.5.5.3** The open space test is conducted under a ceiling with a minimum area of 80 m<sup>2</sup> (860 ft<sup>2</sup>) to simulate an uninterrupted area and a ceiling height of 5 m (16 ft 5 in.). At least 16 nozzles are installed in the ceiling and the fuel package (sofas, as outlined in the IMO specification) are to be arranged per the IMO specification. The test is conducted three times: once each with the ignition under one nozzle, between two nozzles, and between four nozzles. Pass/fail criteria are based on fewer than five nozzles operating, at least one unoperated nozzle beyond those that operate, damage of the sofa cushions (maximum of 50 percent), ceiling surface temperature over ignition [maximum of 260°C (500°F)], and a maximum gas temperature 76 mm (3 in.) below the ceiling of 315°C (600°F).

**C.3.6 FMRC Draft Performance Requirements for Fine Water Spray Systems for the Protection of Wet Benches and Other Processing Equipment.**

**C.3.6.1** The objective is to ensure that the fine water spray system extinguishes pool fires typically found in wet benches and other similar clean room processing equipment.

**C.3.6.2** The detection system has to be approved specifically for use in wet bench applications. Fine water spray systems used for this application are typically of the zoned, deluge type. Operating elements currently used in automatic sprinklers have not been shown to be sufficiently fast enough to prevent significant nonthermal damage.

**C.3.6.3** The simulated clean room is 5.5 m × 3.7 m × 3.7 m (18 ft × 12 ft × 12 ft) high with porous ceiling and floor plates. An airflow (downward) with a velocity of 0.31 m/sec (60 ft/min) is maintained throughout the test. The minimum airflow by the open face of the wet bench is 4.5 m<sup>3</sup>/min/linear m (150 ft<sup>3</sup>/min/linear ft). The wet bench measures approximately 2.3 m × 1.4 m × 2 m (7.5 ft × 4.5 ft × 6.5 ft) high and is divided into two areas: the ventilated subsurface (or plenum) area and the working surface area. The subsurface dimensions are 0.8 m × 2.3 m × 0.6 m (2.6 ft × 7.5 ft × 2 ft) high. The working surface area is 0.8 m × 2.3 m (2.6 ft × 7.5 ft).

**C.3.6.4** All fires have to be extinguished in less than 60 seconds.

**C.3.6.5** Various fire scenarios are conducted to test the fine water spray system for the ventilated subsurface area. These include five pool fires (various sizes) utilizing polypropylene beads and solid coupons for fuel and at least one pool fire for each of the following flammable liquids: acetone, isopropyl alcohol (IPA), and n-heptane. The pan sizes and fire locations for the flammable liquid pool fire are at the discretion of FMRC based on observations of the fine water spray system.

Obstructions are placed within the subsurface area such that approximately 50 percent of the nozzle discharge is blocked.

**C.3.6.6** Two tests are conducted to determine the effectiveness of a single nozzle in an unventilated space utilizing the subsurface area as a test chamber. The first test utilizes a polypropylene pool fire, and the second test uses a flammable liquid pool fire. Pan size and flammable liquid are at the discretion of FMRC based on the outcome of the ventilated subsurface tests. Suitable barriers are placed in the test area to prevent direct impingement on the fire and to provide 50 percent blockage of the discharge.

**C.3.6.7** Several fire scenarios are conducted to test the fine water spray system for the working surface area. These include five pool fires (various sizes) utilizing polypropylene beads and solid coupons for fuel and at least one pool fire for each of the following flammable liquids: acetone, isopropyl alcohol (IPA), and n-heptane. The pan sizes and fire locations for the flammable liquid pool fire are at the discretion of FMRC based on observations made of the fine water spray system.

The flammable liquid fires are also tested at the minimum and maximum nozzle heights, as specified by the manufacturer. A splashing test is conducted in which a single nozzle, located at the minimum vertical height above a pan of liquid containing dye, is discharged at the maximum pressure. None of the contents of the liquid pool are splashed outside a 0.4 m (16 in.) diameter circle centered on the pool.

**C.3.7 FMRC Draft Fire Test Protocol for Water Mist Systems for Local Application Protection.**

**C.3.7.1** The objective of this standard is to ensure that the water mist system will extinguish combustible liquid spray and pool fires. These fires can occur on printing press stands, dip tanks, quench tanks, or lube oil-conditioning systems. The standard assumes the following:

- (1) Room ventilation is normal.
- (2) Obstructions over the protected area do not exceed that tested.
- (3) Fluid is contained within the diked area.

**C.3.7.2** The time required to extinguish the fire scenarios will be reported. The water supply required depends on the occupancy and the authority having jurisdiction.

**C.3.7.3** The system is to be automatically activated by a listed heat or flame detection system.

**C.3.7.4** The water mist system must extinguish the following fires at the maximum and minimum nozzle elevations and spacing. Maximum and minimum heights apply as follows:

- (1) For square pool fires, maximum height only for 1 m × 1 m and 2 m × 2 m pools; maximum and minimum heights for the 3 m × 3 m pool
- (2) For channel fires, maximum height only for Y and 2Y lengths; maximum and minimum heights for 3Y length
- (3) For heptane spray fires, maximum and minimum heights
- (4) For combined pool and spray fires, maximum height only
- (5) For offset pool fire, obstructed pool fire, and spray fire with external ignition source, maximum and minimum heights

**C.3.7.4.1 Pool Fires.** Pool fires are to be in square shapes from 1 m<sup>2</sup>, 4 m<sup>2</sup>, and 9 m<sup>2</sup> (10.8 ft<sup>2</sup>, 43.6 ft<sup>2</sup>, and 96 ft<sup>2</sup>) in area.

**C.3.7.4.2 Obstructed Pool Fires.** The obstruction must be at least equivalent to a 0.6 m (2 ft) diameter drum located 0.5 m (1.6 ft) over the center of the pool.

**C.3.7.4.3 Channel Fires.** Channel fires are to be at the width of the channel and at lengths of one, two, and three times the width.



**C.3.7.4.4 Spray Fires.** Six MW heptane spray fires are conducted with the spray fire axis in the horizontal and vertical directions.

**C.3.7.4.5 Spray and Pool Fires.** Horizontal spray fire tests are conducted with a 6 MW diesel spray fire at two different elevations and two different locations above the surface of a 2 m × 2 m diesel pool fire. A 45 degree spray fire is conducted with a 6 MW diesel spray fire at two locations at one elevation above a 2 m × 2 m diesel pool fire.

**C.3.7.4.6 Diesel Soaked Paper Dust Fire.** A fire involving a quantity of diesel fuel soaked into paper dust.

**C.3.7.5** The tests are conducted in enclosures large enough so that oxygen concentrations do not decrease below 20 percent.

#### **C.4 Underwriters Laboratories Inc., Northbrook, IL, Fire Test Protocols.**

**C.4.1 General.** ANSI/UL 2167, *Standard for Water Mist Nozzles for Fire Protection Service*, contains a series of fire test protocols for evaluating water mist nozzles for listing purposes for the following types of hazards:

- (1) Shipboard machinery spaces
- (2) Shipboard passenger cabins
- (3) Shipboard passenger cabins >12 m<sup>2</sup>
- (4) Shipboard public spaces
- (5) Residential areas
- (6) Light Hazard areas
- (7) Ordinary Hazard Group 1
- (8) Ordinary Hazard Group 2
- (9) Nozzle construction, design, and performance
- (10) Water mist nozzle markings
- (11) Design and installation manual
- (12) Manufacturing and production tests

**C.4.2** The UL 2167 Shipboard Test Protocols closely resemble the IMO test protocols, with some modifications in the number of tests and final acceptance criteria.

**C.4.3 Residential Areas.** The ANSI/UL 2167 Test Protocol for Residential Areas is very similar to that for residential sprinklers. A residential fuel package is used in a compartment fitted with combustible wall panels and ceiling tiles. Six nozzles are installed in the room, which has two open doors on opposite sides, with the fuel package located in a corner. The nozzle closest to the fuel package is installed at its maximum spacing, and the remaining five nozzles are installed using their minimum permitted spacing. Performance criteria include maximum temperatures at several locations. If only one nozzle operates, the manufacturer's design and installation manual has to specify at least a two-nozzle design. If two or three nozzles operate, at least a four-nozzle design is to be specified.

**C.4.4 Light Hazard Areas.** The ANSI/UL 2167 Test Protocol for Light Hazard Areas, in addition to complying with the shipboard public space light hazard fire tests, requires a series of fire tests to measure the ability of the nozzles to limit fire growth in wood cribs.

**C.4.5 Ordinary Hazard Group 1.** The ANSI/UL 2167 Test Protocol for Ordinary Hazard Group 1 Hazard Areas requires that fire tests be conducted both under an open ceiling and in a corner arrangement. The first series of fire tests is conducted under a smooth flat ceiling having provisions for venting gases around the perimeter set at the maximum height specified in the manufacturer's design and installation manual. The fire source consists of a 4.7 m wide × 5.9 m long × 2.1 m high array of Class II commodity (double tri-wall corrugated paper cartons with a five-sided steel liner on a 107 cm × 107 cm × 12.7 cm high hardwood pallet). During the 45-minute test,

ceiling steel temperatures cannot exceed 282°C (540°F) for more than 5 minutes, the number of operating nozzles cannot exceed a design area of 93 m<sup>2</sup>, and damage to the commodity cannot exceed 50 percent. The corner fire tests are similar to the IMO public space corner tests except that empty cardboard cartons are used in lieu of the sofas.

**C.4.6 Ordinary Hazard Group 2.** The ANSI/UL 2167 Test Protocol for Ordinary Hazard Group 2 Hazard Areas is similar to the Ordinary Hazard Group 1 fire tests except that the Group A plastic commodity and test array described in the IMO public space shopping and storage area fire tests is used as the open area test commodity.

**C.4.7 Nozzle Design, Construction, and Performance Requirements.** These requirements are very similar to those specified by IMO. They also include requirements for open nozzles that are not specifically addressed by IMO.

**C.4.8 Nozzle Marking Requirements.** ANSI/UL 2167 contains requirements for the marking of water mist nozzles. In the field, these markings provide a method of verifying that the proper nozzles have been installed.

**C.4.9 Design and Installation Manual.** ANSI/UL 2167 requires the nozzle manufacturer to prepare a design and installation manual containing detailed information concerning the intended use and limitations associated with nozzles.

**C.4.10 Manufacturing and Production Tests.** ANSI/UL 2167 requires the manufacturer to provide an acceptable production control, inspection, and test program. All automatic nozzles are subjected to a production leakage test at twice rated pressure but not less than 3.45 MPa. In addition, as part of a follow-up service program, samples are randomly selected on a periodic basis for follow-up inspections and tests.

#### **C.5 Verband der Schadenversichen eV (VDS, Germany).**

**C.5.1 General.** VDS 2498, *Guidelines for Water Extinguishing Systems Requirements and Test Methods for Fine Spray Nozzles*, contains several fire test protocols. One protocol that has been recognized in Europe is Fine Spray Nozzles for Cable Conduit Tunnels.

**C.5.2 Fine Spray Nozzles for Cable Conduit Tunnels.** This test incorporates a propane burner flame as the ignition source at one end of an array of plastic sheathed cables.

#### **C.6 Bridging the Gap Between Test Protocols and Actual Installations.**

**C.6.1** One of the greatest challenges to engineering of water mist fire suppression systems lies in determining whether the conditions of a particular test protocol are representative of the actual conditions in a given application. An engineering analysis should be applied to evaluate the scale and significance of variations, based on an understanding of the dynamics of the interaction of water mist with fire. At least the following application parameters should be considered:

- (1) Is the fuel similar to the test protocol (liquid or solid fuel, flash point, combustibility, quantity, arrangement)?
- (2) Is the compartment volume equal to or less than the volume of the test room?
- (3) Is the compartment height equal to or less than the test protocol?
- (4) Is the compartment ventilation condition similar (area of openings, position of openings)?
- (5) Are there more obstructions to the distribution of mist than the test protocol?
- (6) Is the duration of protection provided by the listed system appropriate for the actual level of protection desired?



**C.6.2 Extrapolation.** It is recommended that questions about the match between test conditions on which the listing is based and the conditions of the actual installation be addressed through consultation with the listing agency, the authority having jurisdiction, or other agencies with demonstrated qualifications in the field.

## Annex D Reliability

*This annex is not a part of the requirements of this NFPA document but is included for informational purposes only.*

**D.1 General.** Two methods are used to determine reliability: operating experience and predictive techniques.

**D.1.1 Operating Experience.** The Technical Committee on Water Mist Fire Suppression Systems contacted the U.S. Department of Energy, the U.S. Department of Defense, the National Aeronautics and Space Administration, the Coast Guard, passenger cruise ship companies, and other organizations known to have installed water mist systems. The purpose was to determine the number of systems in service and to obtain as much detail as possible for these installations (listed/approved, acceptance test results, loss experience, accidental operations, and so forth).

Based on the information supplied by these sources, a total of 35 installations were identified, for which varying degrees of detail were obtained. The information is summarized in Table D.1.1.

One fire was reported involving a hydraulic oil leak in an engine test cell, and two fires were reported for a system pro-

tecting a thermal oil system on a fiberboard press. Several fires were reported in combustion turbines on offshore oil platforms. Water mist systems operated properly in all cases.

One accidental operation was reported that was attributed to location of a heat detector too close to the exhaust stack in an engine test cell. (See Table D.1.1.)

**D.1.2 Predictive Techniques.** Predictive techniques outlined in ISA-S84.01, *Application of Safety Instrumentation to the Process Industries*, provide guidance to determine the safety integrity level (SIL) of a protection system. The main document establishes SILs needed for various safety systems (SIS). Parts 2, 3, and 4 of ISA-S84.01 provide information on three different methods for determining reliability: simplified equations, fault tree analysis, and Markov analysis. Part 5 of ISA-S84.01 determines the probability of failure on demand (PFD) of Logic Solvers via Markov analysis.

The average probability of failure of a system at various SILs is shown in Table D.1.2.

The user of the system should designate the safety level desired based on either dollar loss or personnel injury. Where a high level of safety is required, the analysis should be done by an independent third party. For lower safety levels, the manufacturer could do the analysis.

The U.S. Navy used reliability studies to evaluate the reliability of halon systems for shipboard use. Approval for service was dependent on a reliability study. The main advantage to the analysis was the identification of single points of failure.

**Table D.1.1 Operating Experience**

| Protected Hazard  | No. of Systems | Time in Operation              | Fires   |      |                      | Application |       |     | Detection/Actuation | Listed |   | Acceptance Test (Y/N) | Notes |
|---|----------------|--------------------------------|---------|------|----------------------|-------------|-------|-----|---------------------|--------|---|-----------------------|-------|
|   |                |                                | Success | Fail | Accidental Operation | Flood       | Local | Yes |                     | No     |   |                       |       |
| 600 HP engine   | 1              | Mid-1996                       | N/A     | N/A  | No                   |             |       | X   | IR flame            |        | X | Y—discharge           | 1     |
| Compressor lube oil system  | 1              | Feb. 1996                      | N/A     | N/A  | No                   |             |       | X   | Smoke               |        | X | Y—discharge           | 2     |
| Engine test cells   |                |                                | 1       | No   | 1                    | X?          |       |     | Heat detection      |        |   |                       | 3     |
| 7 combustion turbines (on oil platforms)  | 7              | Spring 1993                    | Several | No   | Unknown              | X?          |       |     |                     |        |   |                       | 4     |
| 5 diesel fire pumps (on oil platforms)  | 5              | Spring 1993                    | N/A     | N/A  | Unknown              |             |       |     |                     |        |   |                       |       |
| 5 diesel generators (on oil platforms)  | 5              | Spring 1993                    | N/A     | N/A  | Unknown              |             |       |     |                     |        |   |                       |       |
| 2 deep fat fryers (on oil platforms)  | 2              | Spring 1993                    | N/A     | N/A  | Unknown              |             |       |     |                     |        |   |                       |       |
| 6 cruise ships  | ?              | Unknown                        | None    | None | 1                    |             |       |     |                     |        |   |                       | 5     |
| Lube oil systems for 6 combustion turbine driven compressors (natural gas pipeline) | 6              | 1996 (2)<br>1997(2)<br>1998(2) | None    | None | None                 |             |       |     | Combination         |        |   |                       |       |
| Thermal oil system on fiberboard press  | 1              |                                | 2       | None | None                 |             |       | X?  |                     |        | X |                       | 6     |

### Notes:

- At some time after acceptance test, white residue was noted in pipe. Laboratory tests determined it to be zinc oxide. Piping was flushed but residue remained.
- During acceptance test, system failed to operate due to low pressure. Investigation determined that a ¼ in. copper tube had separated from a brass fitting. On second discharge test, 3 of 25 nozzles were plugged, possibly due to use of pipe joint compound. System remained out of service 22 months after installation due to concern for accidental operation during cutting and welding operations. Chalk-like material had formed on interior surface of pipe; believed to be oxide.
- Fire activation: A hydraulic line break occurred on an engine under test. System operated properly and extinguished the fire. Accidental activation: System operated 50 hours into engine test, near end of test cycle. One heat detector may have been located too close to exhaust stack.
- Systems are tested periodically with limited discharge of a few seconds to verify the system is operational.
- Six vessels have water mist protection for engine rooms, dining areas, ballrooms, and escape routes. Engine room systems are manually controlled. One accidental operation, in dining room.
- Oil spray fire burned 2–3 hours, fought unsuccessfully by plant personnel using hose streams. Water mist system was manually activated and extinguished fire within 20 seconds. When press was placed back in service, a second fire developed at an undetected crack in thermal oil system piping. This fire was also extinguished by the water mist system.

**Table D.1.2 Safety Integrity Levels**

| SIL | PFD (average)          |
|-----|------------------------|
| 1   | $10^{-1}$ to $10^{-2}$ |
| 2   | $10^{-2}$ to $10^{-3}$ |
| 3   | $10^{-3}$ to $10^{-4}$ |

Failure rates were determined for the systems designed, but these appeared to be less meaningful than identifying single points of failure. Reliability was improved by eliminating abort valves and installing a manual actuation system to bypass the time delay for the predischage alarm. Manual activation was acceptable because the protected areas onboard ship are constantly occupied.

**D.1.3 Conclusions.** The following conclusions were derived from the review of operating experience:

- (1) Systems are being installed to protect applications for which they have not been tested.

- (2) Users do not have adequate information to determine whether the system has been properly designed and installed. The following additional information is needed:
  - (a) List of system components
  - (b) Design, installation, and maintenance manual
  - (c) Logic diagram
- (3) Acceptance tests are critical to the reliability of the system. Full-flow tests are the best indication that a system has been properly installed. For installations where full-flow tests cannot be done, water should be flowed as close to the nozzles as possible, then diverted to a safe area. The rest of the system should be visually inspected, or gas should flow through the system to be sure it is clear.
- (4) Operating experience is more accurate than predictive techniques in determining the reliability of a system. There is not enough operating experience to date for water mist systems. A questionnaire like the one shown in Figure D.1.3, distributed to users of water mist systems and returned to the Committee, would be helpful in gathering information.
- (5) Where a water mist system is used for life safety, a predictive method should be used to justify that the system is as reliable as the protection system required by code.

### Water Mist System Questionnaire

Questionnaires will be used to determine the reliability of water mist systems. The questionnaire should be completed by the user and forwarded to Staff Liaison, NFPA 750 Water Mist Reliability, 1 Batterymarch Park, Quincy, MA 02169-7471. Phone: (617) 770-3000.

1. Date of installation \_\_\_\_\_
2. The protection is for (combustion turbine, engine test cell, etc.) \_\_\_\_\_
3. Type of system (check box)  Total Compartment  Zoned  Local Application
4. Acceptance test  
Was a full discharge test done (check box)?  Yes  No  
What were the results? \_\_\_\_\_
5. The system is listed by a nationally recognized testing lab:  Yes  No  Unknown
6. The system is actuated by (check box)  Heat  Smoke  Flame  Manual
7. How long has the system been in service? \_\_\_\_\_
8. Has the system actuated (check box)?  Yes  No
9. If yes, the operation was due to (check box)  Fire  Accidental  Other
10. The system operated properly (check box)  Yes  No
11. If the system failed or operated accidentally, please explain: \_\_\_\_\_

Contact: \_\_\_\_\_ Date: \_\_\_\_\_

Phone: \_\_\_\_\_

NOTE: This information will be utilized for statistical information only and will not be available outside of NFPA.

**FIGURE D.1.3 Water Mist System Questionnaire Form to Determine Reliability of Water Mist Systems.**

## Annex E Informational References

**E.1 Referenced Publications.** The documents or portions thereof listed in this annex are referenced within the informational sections of this standard and are not part of the requirements of this document unless also listed in Chapter 2 for other reasons.

**E.1.1 NFPA Publications.** National Fire Protection Association, 1 Batterymarch Park, Quincy, MA 02169-7471.

NFPA 13, *Standard for the Installation of Sprinkler Systems*, 2010 edition.

NFPA 15, *Standard for Water Spray Fixed Systems for Fire Protection*, 2007 edition.

NFPA 20, *Standard for the Installation of Stationary Pumps for Fire Protection*, 2010 edition.

NFPA 25, *Standard for the Inspection, Testing, and Maintenance of Water-Based Fire Protection Systems*, 2008 edition.

NFPA 70®, *National Electrical Code*®, 2008 edition.

NFPA 72®, *National Fire Alarm and Signaling Code*, 2010 edition.

Cote, A. E., and J. L. Linville, eds. “Water Mist Suppression Systems,” in *Fire Protection Handbook*, 18th edition.

### E.1.2 Other Publications.

**E.1.2.1 ANSI Publications.** American National Standards Institute, Inc., 25 West 43rd Street, 4th floor, New York, NY 10036.

ANSI C2, *National Electrical Safety Code*, 1993.

**E.1.2.2 ASME Publications.** American Society of Mechanical Engineers, Three Park Avenue, New York, NY 10016.

ANSI/ASME B31.1, *Power Piping Code*, 1998.

**E.1.2.3 ASTM Publications.** ASTM International, 100 Barr Harbor Drive, P. O. Box C700, West Conshohocken, PA 19428-2959.

ASTM E 380, *Standard Practice for Use of the International System of Units (SI) (the Modernized Metric System)*, 1993.

ASTM E 799, *Standard Practice for Determining Data Criteria and Processing for Liquid Drop Size Analysis*, 1992.

ASTM F 1547, *Standard Guide Listing Relevant Standards and Publications for Commercial Shipbuilding*, 1994.

**E.1.2.4 CSA Publications.** Canadian Standards Association, 5060 Spectrum Way, Mississauga, Ontario, L4W 5N6, Canada.

CAN3-A234.1, *Canadian Metric Practice Guide*, 1979.

**E.1.2.5 FMGR Publications.** FM Global Research, FM Global, 1301 Atwood Avenue, P.O. Box 7500, Johnston, RI 02919.

FMRC *Draft Performance Requirements for Fine Water Spray Systems for the Protection of Combustion Turbine Enclosures, Machinery Spaces, and Special Hazard Machinery Spaces with Volumes Not Exceeding 2825 ft<sup>3</sup> (80 m<sup>3</sup>)*.

FMRC *Draft Performance Requirements for Fine Water Spray Systems for the Protection of Combustion Turbine Enclosures, Machinery Spaces, and Special Hazard Machinery Spaces with Volumes Not Exceeding 9175 ft<sup>3</sup> (260 m<sup>3</sup>)*.

FMRC *Draft Performance Requirements for Fine Water Spray Systems for the Protection of Combustion Turbine Enclosures, Machinery Spaces, and Special Hazard Machinery Spaces with Volumes Exceeding 9175 ft<sup>3</sup> (260 m<sup>3</sup>)*.

FMRC *Draft Performance Requirements for Fine Water Spray Systems for the Protection of Light Hazard Occupancies*.

FMRC *Draft Performance Requirements for Fine Water Spray Systems for the Protection of Wet Benches and Other Processing Equipment*.

FMRC *Draft Performance Requirements for Water Mist Systems for Local Application System Protection*.

**E.1.2.6 FSSA Publications.** Fire Suppression Systems Association, 5024-R Campbell Blvd., Baltimore, MD 21236-5974.

*Pipe Design Handbook for Use with Special Hazards Fire Suppression Systems*.

**E.1.2.7 IMO Publications.** International Maritime Organization, 4 Albert Embankment, London, SE1 7SR, United Kingdom.

IMO *Code for Application of Fire Test Procedures*, 1998.

IMO MSC/Circ. 668, *Alternative Arrangements for Halon Fire-Extinguishing Systems in Machinery Spaces and Pump-Rooms*.

IMO MSC/Circ. 728, *Amendments to the Test Method for Equivalent Water-Based Fire Extinguishing Systems for Machinery Spaces of Category A and Cargo Pump-Rooms Contained in MSC/Circ. 668*.

IMO MSC/Circ. 913, *Guidelines for the Approval of Fixed Water-Based Local Application Fire-Fighting Systems for Use in Category A Machinery Spaces*.

IMO Resolution A.800(19), *Revised Guidelines for Approval of Sprinkler Systems*.

IMO *Standard for Shipboard Corridors, Cabins, and Public Spaces*.

IMO *Standard for Shipboard Machinery Spaces*.

SOLAS Resolution 10, *Fixed Pressure Water Spray Systems*.

**E.1.2.8 ISA Publications.** Instrumentation, Systems, and Automation Society, 67 Alexander Drive, P.O. Box 12277, Research Triangle Park, NC 27709.

ISA-S84.01, *Application of Safety Instrumentation to the Process Industries*, 1996.

**E.1.2.9 UL Publications.** Underwriters Laboratories Inc., 333 Pfingsten Road, Northbrook, IL 60062-2096.

ANSI/UL 2167, *Standard for Water Mist Nozzles for Fire Protection Service*, 2002 with revisions through January 2009.

**E.1.2.10 U.S. Coast Guard Publication.** 2100 Second Street, S.W., Washington, DC 20593-0001.

NVIC 9-97, *Guide to Structural Fire Protection*, 1997.

**E.1.2.11 VDS Publication.** VDS, Pasteurstrasse 17A, Koln 50735, Germany.

VDS 2498, *Guidelines for Water Extinguishing Systems Requirements and Test Methods for Fine Spray Nozzles*, 1996 edition.

## E.2 Informational References. (Reserved)

## E.3 References for Extracts in Informational Sections. (Reserved)

## Index

Copyright © 2009 National Fire Protection Association. All Rights Reserved.

The copyright in this index is separate and distinct from the copyright in the document that it indexes. The licensing provisions set forth for the document are not applicable to this index. This index may not be reproduced in whole or in part by any means without the express written permission of NFPA.

|   |                        |
|---|------------------------|
| <b>-A-</b>  |                        |
| <b>Additive</b>   |                        |
| Definition .....  | 3.3.1, A.3.3.1         |
| <b>Additive Proportioning</b>   |                        |
| Definition .....  | 3.3.2, A.3.3.2         |
| <b>Administration</b> .....   | Chap. 1                |
| Application .....   | 1.3                    |
| Equivalency .....   | 1.5                    |
| Purpose .....   | 1.2, A.1.2             |
| Retroactivity .....   | 1.4                    |
| Scope .....   | 1.1, A.1.1             |
| Units .....   | 1.6, A.1.6             |
| <b>Approved</b>   |                        |
| Definition .....  | 3.2.1, A.3.2.1         |
| <b>Authority Having Jurisdiction (AHJ)</b>  |                        |
| Definition .....  | 3.2.2, A.3.2.2         |
| <b>-C-</b>  |                        |
| <b>Calculations</b> .....   | Chap. 9                |
| Calculation Procedures for Propellant Gas<br>or Atomizing Media .....   | 9.4                    |
| Air Pressure to Water Pressure Ratio .....  | 9.4.5                  |
| Calculation Procedure .....   | 9.4.2                  |
| General .....   | 9.4.1                  |
| Calculations .....  | 9.4.1.1                |
| Maximum and Minimum Pressures .....   | 9.4.1.2                |
| Volume (Gas Quantity) and Pressure .....  | 9.4.1.3                |
| Engineered Systems .....  | 9.4.1.3.2              |
| Pre-Engineered Systems .....  | 9.4.1.3.1              |
| Initial Pressure .....  | 9.4.3                  |
| Results .....   | 9.4.6                  |
| Verification .....  | 9.4.4                  |
| Darcy-Weisbach Calculation Method for Intermediate<br>and High Pressure, Single Fluid, Single<br>Liquid Phase Systems ..... | 9.2, A.9.2             |
| General .....   | 9.1                    |
| Flow Calculation Procedures .....   | 9.1.1                  |
| Modifications .....   | 9.1.2, A.9.1.2         |
| Pre-Engineered Systems .....  | 9.1.3                  |
| Special Valves, Strainers, and Other Devices .....  | 9.1.4, A.9.1.4         |
| Hazen-Williams Calculation Method<br>(Low Pressure Systems) .....   | 9.3, A.9.3             |
| Equivalent Pipe Lengths of Valves and Fittings .....  | 9.3.6                  |
| C Factor Values .....   | 9.3.6.4                |
| Friction Loss Formula .....   | 9.3.2                  |
| Hydraulic Junction Points .....   | 9.3.5                  |
| Normal Pressure Formula .....   | 9.3.4                  |
| Velocity Pressure Formula .....   | 9.3.3                  |
| Working Pressure Limits and Additives .....   | 9.3.1                  |
| <b>-D-</b>  |                        |
| <b>Definitions</b> .....  | Chap. 3                |
| <b>Deluge System</b>  |                        |
| Definition .....  | 3.3.3                  |
| <b>Design Objectives and Fire Test Protocols</b> .....  | Chap. 8                |
| Application Parameters .....  | 8.4                    |
| Compartment Variables .....   | 8.4.1, A.8.4.1         |
| Compartment Geometry .....  | 8.4.1.1                |
| Ventilation .....   | 8.4.1.2                |
| Forced Ventilation .....  | 8.4.1.2.2              |
| Natural Ventilation .....   | 8.4.1.2.1, A.8.4.1.2.1 |
| Fire Hazard Classification .....  | 8.4.2                  |
| Combustible Loading .....   | 8.4.2.1                |
| Fuel Type .....   | 8.4.2.2                |
| Class A Fires .....   | 8.4.2.2.3              |
| Class B Fires .....   | 8.4.2.2.4              |
| Class C Fires .....   | 8.4.2.2.5              |
| Combination Fires .....   | 8.4.2.2.6              |
| Fire Location .....   | 8.4.3                  |
| Obstructions and Shielding .....  | 8.4.4                  |
| General .....   | 8.1, A.8.1             |
| Application Characteristics .....   | 8.1.2                  |
| Application Evaluations .....   | 8.1.3                  |
| Listing .....   | 8.1.1                  |
| Pre-Engineered Systems .....  | 8.1.4                  |
| Listing Evaluations .....   | 8.2, A.8.2             |
| Applicability .....   | 8.2.4                  |
| Application Parameters .....  | 8.2.3                  |
| Design and Installation Manual .....  | 8.2.6                  |
| Fire Test Protocols .....   | 8.2.2, A.8.2.2         |
| Scope .....   | 8.2.1                  |
| Testing .....   | 8.2.5                  |
| Performance Objectives .....  | 8.3                    |
| Fire Performance Objectives .....   | 8.3.1, A.8.3.1         |
| Fire Control .....  | 8.3.1.1                |
| Fire Extinguishment .....   | 8.3.1.3                |
| Fire Suppression .....  | 8.3.1.2                |
| Reliability .....   | 8.5                    |
| <b>D<sub>v</sub></b>  |                        |
| Definition .....  | 3.3.4, A.3.3.4         |
| <b>-E-</b>  |                        |
| <b>Enclosure</b>  |                        |
| Definition .....  | 3.3.5, A.3.3.5         |
| <b>Escutcheon</b>   |                        |
| Definition .....  | 3.3.6                  |
| <b>Examples of Fire Test Protocols</b> .....  | Annex C                |
| <b>Explanatory Material</b> .....   | Annex A                |
| <b>-F-</b>  |                        |
| <b>Fire Control</b>   |                        |
| Definition .....  | 3.3.7                  |
| <b>Fire Extinguishment</b>  |                        |
| Definition .....  | 3.3.8                  |
| <b>Fire Suppression</b>   |                        |
| Definition .....  | 3.3.9                  |
| <b>-G-</b>  |                        |
| <b>General</b> .....  | Chap. 4                |
| General .....   | 4.1, A.4.1             |
| Use and Limitations .....   | 4.1.1                  |
| Safety .....  | 4.2, A.4.2             |
| Electrical Clearances .....   | 4.2.1, A.4.2.1         |
| Environmental Factors .....   | 4.2.2                  |
| <b>-H-</b>  |                        |
| <b>High Pressure System</b>   |                        |
| Definition .....  | 3.3.10                 |



|  |                      |
|--|----------------------|
| <b>-I-</b>   |                      |
| <b>Informational References</b> .....  | Annex E              |
| <b>Installation Requirements</b> .....   | Chap. 7              |
| Electrical Systems .....   | 7.9                  |
| Automatic and Manual Activation .....  | 7.9.4                |
| Control Equipment .....  | 7.9.2                |
| Alarms .....   | 7.9.2.4              |
| Installation Standards .....   | 7.9.2.1              |
| Primary and Standby Power .....  | 7.9.2.3              |
| Supervision .....  | 7.9.2.2              |
| Electrical Equipment .....   | 7.9.1                |
| Fire Detection .....   | 7.9.3                |
| Fittings .....   | 7.4                  |
| Listing .....  | 7.4.1                |
| Low Pressure Systems .....   | 7.4.2                |
| Pressure Rating .....  | 7.4.3                |
| Gas and Water Storage Containers .....   | 7.5                  |
| Accessibility .....  | 7.5.2                |
| Damage .....   | 7.5.4                |
| High Pressure Storage Containers .....   | 7.5.5                |
| Container Securement .....   | 7.5.5.5              |
| Manifolded Cylinders .....   | 7.5.5.3              |
| Preshipping Testing .....  | 7.5.5.2              |
| Standards .....  | 7.5.5.1              |
| Storage Temperatures .....   | 7.5.5.4              |
| Intermediate and Low Pressure Storage Cylinders .....                                | 7.5.6                |
| Securement .....   | 7.5.6.7              |
| Storage Temperature .....  | 7.5.6.6              |
| Listing .....  | 7.5.1                |
| Location .....   | 7.5.3, A.7.5.3       |
| General .....  | 7.1                  |
| Corrosive Environments .....   | 7.1.3                |
| Installation and Testing Procedures .....  | 7.1.5                |
| Listing .....  | 7.1.1                |
| Mechanical and Chemical Damage .....   | 7.1.4                |
| System Design Manual .....   | 7.1.2                |
| Nozzles .....  | 7.2                  |
| Distance Below Ceilings .....  | 7.2.6                |
| Distance from Walls .....  | 7.2.4                |
| Escutcheons and Cover Plates .....   | 7.2.9                |
| General .....  | 7.2.1                |
| Nozzle Height Limitations .....  | 7.2.2                |
| Nozzle Protection .....  | 7.2.8                |
| Nozzle Spacing Limitations .....   | 7.2.3                |
| Obstructions to Nozzle Discharge .....   | 7.2.5, A.7.2.5       |
| Spacing Under Pitched or Curved Surfaces .....                                       | 7.2.7                |
| Thermally Activated Nozzle Temperature Ratings .....                                 | 7.2.10               |
| Pipe and Tubing .....  | 7.3                  |
| Installation Manual .....  | 7.3.1                |
| Installation Standards .....   | 7.3.2                |
| Listing .....  | 7.3.4                |
| Location of Hangers and Supports .....   | 7.3.7                |
| Piping Support .....   | 7.3.5                |
| Pressure Rating .....  | 7.3.3                |
| Protection of System Components Against Damage Where<br>Subject to Earthquakes ..... | 7.3.8, A.7.3.8       |
| System Drainage .....  | 7.3.6                |
| Pumps and Pump Controllers .....   | 7.6                  |
| Automatic Start .....  | 7.6.2                |
| Single Family Dwellings .....  | 7.6.4                |
| Sizing .....   | 7.6.1, A.7.6.1       |
| Supervisory Service .....  | 7.6.3                |
| Test Fittings or Hose Outlets .....  | 7.6.5                |
| Strainers and Filters .....  | 7.7                  |
| Installation .....   | 7.7.2                |
| Location .....   | 7.7.1                |
| Test Connections .....   | 7.10                 |
| Valves and Pressure Gauges .....   | 7.8                  |
| Check Valves and Backflow Preventers .....   | 7.8.4                |
| Control and Activation Valves .....  | 7.8.2                |
| General .....  | 7.8.1                |
| Indicating Valves .....  | 7.8.1.7              |
| Valve Accessibility .....  | 7.8.1.6              |
| Valve Identification .....   | 7.8.1.5              |
| Valve Supervision .....  | 7.8.1.8              |
| Pressure Gauges .....  | 7.8.5                |
| Pressure Regulating and Pressure Relief Valves .....                                 | 7.8.3                |
| Compressed Gas Pressure Regulating Valves (PRVs) ...                                 | 7.8.3.2              |
| Water Pressure Regulating Valves .....   | 7.8.3.1              |
| <b>Intermediate Pressure System</b>  |                      |
| Definition .....   | 3.3.11               |
| <b>-L-</b>   |                      |
| <b>Listed</b>  |                      |
| Definition .....   | 3.2.3, A.3.2.3       |
| <b>Low Pressure System</b>   |                      |
| Definition .....   | 3.3.12               |
| <b>-M-</b>   |                      |
| <b>Marine Systems</b> .....  | Chap. 14             |
| Flammable Liquids — Total Area Protection .....                                      | 14.3                 |
| General .....  | 14.3.1               |
| Location of Pressure Source Components .....   | 14.3.7               |
| Machinery Spaces on Towing Vessels and Other<br>Uninspected Vessels .....            | 14.3.9               |
| Manual Actuation .....   | 14.3.3, A.14.3.3     |
| Operational Tests .....  | 14.3.8               |
| Power Supplies .....   | 14.3.6, A.14.3.6     |
| Spaces .....   | 14.3.2               |
| Time Delay and Signals .....   | 14.3.4, A.14.3.4     |
| Water Supply .....   | 14.3.5               |
| Freshwater Supply .....  | 14.3.5.4             |
| Sea Inlet .....  | 14.3.5.7, A.14.3.5.7 |
| Water and Atomizing Media Quality .....  | 14.3.5.6, A.14.3.5.6 |
| General .....  | 14.1                 |
| Controls and Alarms .....  | 14.1.7               |
| Copper Pipe .....  | 14.1.12              |
| Galvanic Corrosion .....   | 14.1.12.4            |
| Efficacy and Reliability .....   | 14.1.2, A.14.1.2     |
| General Design .....   | 14.1.4               |
| Listing and Approval .....   | 14.1.3               |
| Marine Definitions .....   | 14.1.1               |
| Flammable Liquid Hazard Systems .....  | 14.1.1.2             |
| Sprinkler Equivalent Systems .....   | 14.1.1.1             |
| Mounting and Hanging .....   | 14.1.5, A.14.1.5     |
| Pipe Penetrations .....  | 14.1.8, A.14.1.8     |
| Piping .....   | 14.1.11              |
| Pump Redundancy .....  | 14.1.6, A.14.1.6     |
| Pump Test Connection .....   | 14.1.10, A.14.1.10   |
| Shore Connection .....   | 14.1.9               |
| Shore Connection Identification .....  | 14.1.9.4, A.14.1.9.4 |
| Shore Connection Manifold .....  | 14.1.9.3             |
| Strainers and Filters .....  | 14.1.13              |
| Human Factors .....  | 14.4, A.14.4         |
| Requirements for Water Mist Systems<br>on Combatant Vessels .....                    | 14.5, A.14.5         |
| Sprinkler Equivalent Systems .....   | 14.2                 |
| Design .....   | 14.2.11              |
| Minimum Protection of Openings .....   | 14.2.11.7            |
| Room Design .....  | 14.2.11.6            |
| Location .....   | 14.2.13              |
| <b>-P-</b>   |                      |
| <b>Plans and Documentation</b> .....   | Chap. 11             |
| Detection, Actuation, and Control Systems Documentation ...                          | 11.4                 |
| As-Built Installation Drawings .....   | 11.4.2               |
| Documentation .....  | 11.4.3               |
| General .....  | 11.4.1               |
| Reports .....  | 11.4.6               |
| System Design Information Sign .....   | 11.4.4               |
| Written Sequence of Operation .....  | 11.4.5               |

No reproduction or networking permitted without license from IIR

|   |                      |
|---|----------------------|
| Hydraulic Calculation Documentation .....             | 11.2, A.11.2         |
| Detailed Work Sheets .....                            | 11.2.4               |
| Graph Sheet .....                                     | 11.2.5               |
| Hydraulic Calculation Sheets .....                    | 11.2.1               |
| Pre-Engineered Systems .....                          | 11.2.2               |
| Summary Sheet .....                                   | 11.2.3               |
| Pneumatic Calculation Documentation .....             | 11.3                 |
| Detailed Work Sheets for Pneumatic Calculations ..... | 11.3.4               |
| Pneumatic Calculation Sheets .....                    | 11.3.1               |
| Pre-Engineered Systems .....                          | 11.3.2               |
| Summary Sheet .....                                   | 11.3.3               |
| Working Plans .....                                   | 11.1                 |
| Component Identification .....                        | 11.1.4               |
| Deviations from Approved Plans .....                  | 11.1.2               |
| Required Information .....                            | 11.1.5               |
| Submittal of Working Plans .....                      | 11.1.1               |
| Symbols .....   | 11.1.6, A.11.1.6     |
| Working Plans .....                                   | 11.1.3               |
| <b>Propellant</b> .....                               |                      |
| Definition .....                                      | 3.3.13               |
| <b>-R-</b>  |                      |
| <b>Referenced Publications</b> .....                  | Chap. 2              |
| General .....   | 2.1                  |
| NFPA Publications .....                               | 2.2                  |
| Other Publications .....                              | 2.3                  |
| References for Extracts in Mandatory Sections .....   | 2.4                  |
| <b>Reliability</b> .....                              | Annex D              |
| <b>Research Summary</b> .....                         | Annex B              |
| <b>-S-</b>  |                      |
| <b>Shall</b> .....                                    |                      |
| Definition .....                                      | 3.2.4                |
| <b>Shall be Considered</b> .....                      |                      |
| Definition .....                                      | 3.3.14, A.3.3.14     |
| <b>Should</b> .....                                   |                      |
| Definition .....                                      | 3.2.5                |
| <b>Single-Fluid System</b> .....                      |                      |
| Definition .....                                      | 3.3.15               |
| <b>Standard</b> .....                                 |                      |
| Definition .....                                      | 3.2.6                |
| <b>Supervision</b> .....                              |                      |
| Definition .....                                      | 3.3.16               |
| <b>System Acceptance</b> .....                        | Chap. 12             |
| Acceptance Requirements .....                         | 12.2, A.12.2         |
| Air Tests .....                                       | 12.2.3, A.12.2.3     |
| Flushing or Cleaning of Piping .....                  | 12.2.1               |
| System Pipe or Tube .....                             | 12.2.1.2             |
| Water Supply Connection .....                         | 12.2.1.1             |
| Hydrostatic Tests .....                               | 12.2.2               |
| General .....   | 12.2.2.1             |
| Test Blanks .....                                     | 12.2.2.1.4           |
| Intermediate and High Pressure Systems .....          | 12.2.2.3, A.12.2.2.3 |
| Low Pressure System .....                             | 12.2.2.2             |
| Preliminary Functional Tests .....                    | 12.2.5               |
| Alarm Receiving Office .....                          | 12.2.5.1             |
| Auxiliary Functions .....                             | 12.2.5.4             |
| Cross-Zoned Detection Systems .....                   | 12.2.5.7             |
| Detector Testing .....                                | 12.2.5.3             |
| Manual Pull Stations .....                            | 12.2.5.5             |
| Release Mechanisms .....                              | 12.2.5.2             |
| Supervised Circuits .....                             | 12.2.5.6             |
| Review of Components .....                            | 12.2.4               |
| Review of Electrical Components .....                 | 12.2.4.2             |
| Abort Switches .....                                  | 12.2.4.2.8           |
| Review of Mechanical Components .....                 | 12.2.4.1             |
| System Design Information Sign .....                  | 12.2.7               |
| System Operational Tests .....                        | 12.2.6               |
| Approval of Water Mist Systems .....                  | 12.1                 |

|  |                        |
|--|------------------------|
| <b>System Components and Hardware</b> .....            | Chap. 5                |
| Compatibility .....                                    | 5.1.1                  |
| Detection, Actuation, Alarm, and Control Systems ..... | 5.1.0                  |
| Automatic Detection .....                              | 5.1.0.2                |
| Existing Detection Systems .....                       | 5.1.0.2.3              |
| Listing .....  | 5.1.0.2.1, A.5.1.0.2.1 |
| Primary and Standby Power .....                        | 5.1.0.2.2              |
| Control Equipment .....                                | 5.1.0.4                |
| Electrical Control Equipment .....                     | 5.1.0.4.1              |
| Listing .....  | 5.1.0.4.2              |
| Pneumatic Control Equipment .....                      | 5.1.0.4.3              |
| General .....  | 5.1.0.1                |
| Automatic Systems .....                                | 5.1.0.1.2              |
| Installation, Testing, and Maintenance .....           |                        |
| Standards .....  | 5.1.0.1.1              |
| Manual Systems .....                                   | 5.1.0.1.3              |
| Operating Devices .....                                | 5.1.0.3                |
| Devices .....  | 5.1.0.3.1              |
| Emergency Release Device .....                         | 5.1.0.3.5              |
| Manual Release Device .....                            | 5.1.0.3.6              |
| Operating Methods .....                                | 5.1.0.3.2              |
| Service Conditions .....                               | 5.1.0.3.3              |
| Supplementary Equipment .....                          |                        |
| and Interfaces .....                                   | 5.1.0.3.7, A.5.1.0.3.7 |
| Temperature Limitations .....                          | 5.1.0.3.4              |
| Fittings .....   | 5.4                    |
| General .....  | 5.4.1, A.5.4.1         |
| Conversion Fittings .....                              | 5.4.1.2                |
| Fittings .....   | 5.4.1.1                |
| Intermediate and High Pressure Systems .....           | 5.4.3                  |
| Low Pressure Systems .....                             | 5.4.2                  |
| Gas and Water Containers .....                         | 5.2                    |
| Capacity .....   | 5.2.1                  |
| Design .....   | 5.2.2                  |
| Design Pressure .....                                  | 5.2.2.4                |
| Excess Pressure .....                                  | 5.2.2.5                |
| Gas Container Nameplate .....                          | 5.2.2.8                |
| Installation .....                                     | 5.2.2.1, A.5.2.2.1     |
| Pressure Indicator .....                               | 5.2.2.9                |
| Shipping Containers .....                              | 5.2.2.3                |
| Sight Glasses .....                                    | 5.2.2.7                |
| Specifications .....                                   | 5.2.2.2, A.5.2.2.2     |
| Water Container Nameplate .....                        | 5.2.2.6                |
| Multiple Container Systems .....                       | 5.2.3                  |
| General .....  | 5.1                    |
| Component Listing .....                                | 5.1.1                  |
| Corrosion Resistance .....                             | 5.1.3                  |
| Corrosive Atmospheres .....                            | 5.1.3.1                |
| Water Additives .....                                  | 5.1.3.2, A.5.1.3.2     |
| Working Pressure .....                                 | 5.1.2                  |
| Hangers/Supports .....                                 | 5.5                    |
| Bending .....  | 5.5.4                  |
| Listed Inserts .....                                   | 5.5.5                  |
| Listing .....  | 5.5.2                  |
| Powder-Driven Fasteners .....                          | 5.5.6                  |
| Special Designed Hangers .....                         | 5.5.3                  |
| Supports .....   | 5.5.1                  |
| Nozzles .....  | 5.6                    |
| Corrosion Protection .....                             | 5.6.4                  |
| Frangible Discs and Blowoff Caps .....                 | 5.6.6                  |
| Listing .....  | 5.6.1, A.5.6.1         |
| Marking .....  | 5.6.3                  |
| New Nozzles .....                                      | 5.6.2                  |
| Protective Coatings .....                              | 5.6.5                  |
| Thermally Activated Nozzles .....                      | 5.6.7                  |
| Piping and Tube .....                                  | 5.3                    |
| General .....  | 5.3.1, A.5.3.1         |
| Intermediate and High Pressure Systems .....           | 5.3.4                  |
| Low Pressure Systems .....                             | 5.3.3                  |
| Other Types of Pipe or Tube .....                      | 5.3.2, A.5.3.2         |
| Pipe or Tube Bending .....                             | 5.3.6, A.5.3.6         |
| Pipe or Tube Identification .....                      | 5.3.5                  |
| Pump Systems .....                                     | 5.9                    |

|   |                      |  |  |
|---|----------------------|--|--|
| Controllers .....   | 5.9.3                |  |  |
| Listing .....   | 5.9.3.1              |  |  |
| Service-Disconnecting Means .....                                   | 5.9.3.2              |  |  |
| Power Supply .....  | 5.9.2                |  |  |
| Arrangement .....   | 5.9.2.3              |  |  |
| Independent Service Feed .....                                      | 5.9.2.2              |  |  |
| Installation Standards .....  | 5.9.2.1              |  |  |
| Pumps .....   | 5.9.1                |  |  |
| Automatic Start .....   | 5.9.1.4              |  |  |
| Capacity .....  | 5.9.1.2              |  |  |
| Gauges .....  | 5.9.1.5, A.5.9.1.5   |  |  |
| Installation Standard .....   | 5.9.1.1              |  |  |
| Overpressure .....  | 5.9.1.3              |  |  |
| Pump Information Plate .....  | 5.9.1.6              |  |  |
| Unloader Valves .....   | 5.9.1.7              |  |  |
| Strainers and Filters .....   | 5.8                  |  |  |
| Corrosion Resistance .....  | 5.8.3                |  |  |
| Flow, Pressure, and Duration Sizing .....                           | 5.8.2, A.5.8.2       |  |  |
| Flush-Out Connection .....  | 5.8.5                |  |  |
| Listing .....   | 5.8.4                |  |  |
| Listing .....   | 5.8.1                |  |  |
| Nozzle Strainers and Filters .....                                  | 5.8.7                |  |  |
| Sizing .....  | 5.8.6                |  |  |
| Spare Strainers and Filters .....                                   | 5.8.8                |  |  |
| Valves .....  | 5.7                  |  |  |
| Compatibility .....   | 5.7.2                |  |  |
| Identification of Valves .....                                      | 5.7.3                |  |  |
| Valve Listing .....   | 5.7.1                |  |  |
| <b>System Maintenance</b> .....                                     | Chap. 13             |  |  |
| Inspection and Testing .....  | 13.2                 |  |  |
| Components and Systems .....  | 13.2.1               |  |  |
| Frequencies .....   | 13.2.2, A.13.2.2     |  |  |
| High Pressure Cylinders .....                                       | 13.2.5               |  |  |
| Restoration .....   | 13.2.3, A.13.2.3     |  |  |
| Specialized Equipment .....   | 13.2.4               |  |  |
| Maintenance .....   | 13.3                 |  |  |
| Responsibility of the Owner or Occupant .....                       | 13.1                 |  |  |
| Changes of Occupancy .....  | 13.1.5               |  |  |
| Correction or Repair .....  | 13.1.3               |  |  |
| General .....   | 13.1.1               |  |  |
| Notification .....  | 13.1.2               |  |  |
| Return to Service .....   | 13.1.6               |  |  |
| System Re-evaluation .....  | 13.1.4               |  |  |
| Training .....  | 13.4                 |  |  |
| <b>System Requirements</b> .....                                    | Chap. 6              |  |  |
| Additive Systems .....  | 6.6                  |  |  |
| General .....   | 6.1                  |  |  |
| Media System Types .....  | 6.5, A.6.5           |  |  |
| Nozzle Types .....  | 6.3                  |  |  |
| System Applications .....   | 6.2                  |  |  |
| Local-Application Systems .....                                     | 6.2.1                |  |  |
| Total Compartment Application Systems .....                         | 6.2.2                |  |  |
| Zoned Application Systems .....                                     | 6.2.3, A.6.2.3       |  |  |
| System Requirements .....   | 6.4                  |  |  |
| Deluge Systems .....  | 6.4.1                |  |  |
| Dry Pipe Systems .....  | 6.4.4                |  |  |
| Preaction Systems .....   | 6.4.3                |  |  |
| Wet Pipe Systems .....  | 6.4.2                |  |  |
| <b>-T-</b>  |                      |  |  |
| <b>Total Compartment Application System</b> .....                   |                      |  |  |
| Definition .....  | 3.3.17               |  |  |
| <b>Twin-Fluid System</b> .....                                      |                      |  |  |
| Definition .....  | 3.3.18               |  |  |
| <b>-W-</b>  |                      |  |  |
| <b>Water Mist</b> .....   |                      |  |  |
| Definition .....  | 3.3.19, A.3.3.19     |  |  |
| <b>Water Mist Nozzle</b> .....                                      |                      |  |  |
| Automatic Water Mist Nozzles .....                                  |                      |  |  |
| Definition .....  | 3.3.21.1             |  |  |
| Definition .....  | 3.3.21               |  |  |
| Hybrid Water Mist Nozzles .....                                     |                      |  |  |
| Definition .....  | 3.3.21.2, A.3.3.21.2 |  |  |
| Nonautomatic Water Mist Nozzles (Open) .....                        |                      |  |  |
| Definition .....  | 3.3.21.3             |  |  |
| <b>Water Mist System</b> .....                                      |                      |  |  |
| Definition .....  | 3.3.22               |  |  |
| Dry Pipe Water Mist System .....                                    |                      |  |  |
| Definition .....  | 3.3.22.1             |  |  |
| Engineered Water Mist Systems .....                                 |                      |  |  |
| Definition .....  | 3.3.22.2             |  |  |
| Local-Application Water Mist System .....                           |                      |  |  |
| Definition .....  | 3.3.22.3             |  |  |
| Pre-engineered Water Mist Systems .....                             |                      |  |  |
| Definition .....  | 3.3.22.5, A.3.3.22.5 |  |  |
| Preaction Water Mist System .....                                   |                      |  |  |
| Definition .....  | 3.3.22.4             |  |  |
| Wet Pipe Water Mist System .....                                    |                      |  |  |
| Definition .....  | 3.3.22.6             |  |  |
| <b>Water Mist, Atomizing Media</b> .....                            | 3.3.20               |  |  |
| <b>Water Supplies and Atomizing Media</b> .....                     | Chap. 10             |  |  |
| Atomizing Media for Twin-Fluid Systems .....                        | 10.6                 |  |  |
| Air Compressors .....   | 10.6.8               |  |  |
| Check Valves .....  | 10.6.6               |  |  |
| Filters .....   | 10.6.7               |  |  |
| General .....   | 10.6.1               |  |  |
| Moisture Content .....  | 10.6.4               |  |  |
| Plant Air .....   | 10.6.2               |  |  |
| Regulators .....  | 10.6.5               |  |  |
| Supervision .....   | 10.6.3               |  |  |
| Duration .....  | 10.3, A.10.3         |  |  |
| General .....   | 10.1                 |  |  |
| Pressure Gauges .....   | 10.7                 |  |  |
| Quantity .....  | 10.2, A.10.2         |  |  |
| Reserve Supplies .....  | 10.4                 |  |  |
| Water Supplies .....  | 10.5                 |  |  |
| Fire Department Connection .....                                    | 10.5.5, A.10.5.5     |  |  |
| Pumps .....   | 10.5.2               |  |  |
| Supervision .....   | 10.5.2.4             |  |  |
| Diesel-Driven Pumps .....   | 10.5.2.4.2           |  |  |
| Electric Pumps .....  | 10.5.2.4.1           |  |  |
| Storage Containers .....  | 10.5.4               |  |  |
| Tanks .....   | 10.5.3               |  |  |
| Water Quality .....   | 10.5.1, A.10.5.1     |  |  |
| Demineralized Water .....   | 10.5.1.7             |  |  |
| Filter Rating or Strainer Mesh Openings .....                       | 10.5.1.6             |  |  |
| Filters and Strainers — Nozzles .....                               | 10.5.1.4             |  |  |
| Filters and Strainers — Water Supply Connection<br>and Risers ..... | 10.5.1.5             |  |  |
| <b>Working Pressure</b> .....                                       |                      |  |  |
| Definition .....  | 3.3.23               |  |  |
| <b>-Z-</b>  |                      |  |  |
| <b>Zoned Application System</b> .....                               |                      |  |  |
| Definition .....  | 3.3.24               |  |  |



## Sequence of Events Leading to Issuance of an NFPA Committee Document

### Step 1: Call for Proposals

- Proposed new Document or new edition of an existing Document is entered into one of two yearly revision cycles, and a Call for Proposals is published.

### Step 2: Report on Proposals (ROP)

- Committee meets to act on Proposals, to develop its own Proposals, and to prepare its Report.
- Committee votes by written ballot on Proposals. If two-thirds approve, Report goes forward. Lacking two-thirds approval, Report returns to Committee.
- Report on Proposals (ROP) is published for public review and comment.

### Step 3: Report on Comments (ROC)

- Committee meets to act on Public Comments to develop its own Comments, and to prepare its report.
- Committee votes by written ballot on Comments. If two-thirds approve, Report goes forward. Lacking two-thirds approval, Report returns to Committee.
- Report on Comments (ROC) is published for public review.

### Step 4: Technical Report Session

- “Notices of intent to make a motion” are filed, are reviewed, and valid motions are certified for presentation at the Technical Report Session. (“Consent Documents” that have no certified motions bypass the Technical Report Session and proceed to the Standards Council for issuance.)
- NFPA membership meets each June at the Annual Meeting Technical Report Session and acts on Technical Committee Reports (ROP and ROC) for Documents with “certified amending motions.”
- Committee(s) vote on any amendments to Report approved at NFPA Annual Membership Meeting.

### Step 5: Standards Council Issuance

- Notification of intent to file an appeal to the Standards Council on Association action must be filed within 20 days of the NFPA Annual Membership Meeting.
- Standards Council decides, based on all evidence, whether or not to issue Document or to take other action, including hearing any appeals.

## Committee Membership Classifications

The following classifications apply to Technical Committee members and represent their principal interest in the activity of the committee.

- M *Manufacturer*: A representative of a maker or marketer of a product, assembly, or system, or portion thereof, that is affected by the standard.
- U *User*: A representative of an entity that is subject to the provisions of the standard or that voluntarily uses the standard.
- I/M *Installer/Maintainer*: A representative of an entity that is in the business of installing or maintaining a product, assembly, or system affected by the standard.
- L *Labor*: A labor representative or employee concerned with safety in the workplace.
- R/T *Applied Research/Testing Laboratory*: A representative of an independent testing laboratory or independent applied research organization that promulgates and/or enforces standards.
- E *Enforcing Authority*: A representative of an agency or an organization that promulgates and/or enforces standards.
- I *Insurance*: A representative of an insurance company, broker, agent, bureau, or inspection agency.
- C *Consumer*: A person who is, or represents, the ultimate purchaser of a product, system, or service affected by the standard, but who is not included in the *User* classification.
- SE *Special Expert*: A person not representing any of the previous classifications, but who has a special expertise in the scope of the standard or portion thereof.

#### NOTES:

1. “Standard” connotes code, standard, recommended practice, or guide.
2. A representative includes an employee.
3. While these classifications will be used by the Standards Council to achieve a balance for Technical Committees, the Standards Council may determine that new classifications of members or unique interests need representation in order to foster the best possible committee deliberations on any project. In this connection, the Standards Council may make appointments as it deems appropriate in the public interest, such as the classification of “Utilities” in the National Electrical Code Committee.
4. Representatives of subsidiaries of any group are generally considered to have the same classification as the parent organization.

# NFPA Document Proposal Form

**NOTE: All Proposals must be received by 5:00 pm EST/EDST on the published Proposal Closing Date.**

For further information on the standards-making process, please contact the Codes and Standards Administration at 617-984-7249 or visit [www.nfpa.org/codes](http://www.nfpa.org/codes).

For technical assistance, please call NFPA at 1-800-344-3555.

## FOR OFFICE USE ONLY

Log #: \_\_\_\_\_

Date Rec'd: \_\_\_\_\_

Please indicate in which format you wish to receive your ROP/ROC  electronic  paper  download  
(Note: If choosing the download option, you must view the ROP/ROC from our website; no copy will be sent to you.)

Date April 1, 200X Name John J. Doe Tel. No. 716-555-1234

Company Air Canada Pilot's Association Email \_\_\_\_\_

Street Address 123 Summer Street Lane City Lewiston State NY Zip 14092

**\*\*\*If you wish to receive a hard copy, a street address MUST be provided. Deliveries cannot be made to PO boxes.**

Please indicate organization represented (if any) \_\_\_\_\_

1. (a) NFPA Document Title National Fuel Gas Code NFPA No. & Year 54, 200X Edition

(b) Section/Paragraph 3.3

2. Proposal Recommends (check one):  new text  revised text  deleted text

3. Proposal (include proposed new or revised wording, or identification of wording to be deleted): [Note: Proposed text should be in legislative format; i.e., use underscore to denote wording to be inserted (inserted wording) and strike-through to denote wording to be deleted (~~deleted wording~~).]

Revise definition of effective ground-fault current path to read:

3.3.78 Effective Ground-Fault Current Path. An intentionally constructed, permanent, low impedance electrically conductive path designed and intended to carry underground electric fault current conditions from the point of a ground fault on a wiring system to the electrical supply source.

4. Statement of Problem and Substantiation for Proposal: (Note: State the problem that would be resolved by your recommendation; give the specific reason for your Proposal, including copies of tests, research papers, fire experience, etc. If more than 200 words, it may be abstracted for publication.)

Change uses proper electrical terms.

## 5. Copyright Assignment

(a)  I am the author of the text or other material (such as illustrations, graphs) proposed in the Proposal.

(b)  Some or all of the text or other material proposed in this Proposal was not authored by me. Its source is as follows: (please identify which material and provide complete information on its source)

ABC Co.

I hereby grant and assign to the NFPA all and full rights in copyright in this Proposal and understand that I acquire no rights in any publication of NFPA in which this Proposal in this or another similar or analogous form is used. Except to the extent that I do not have authority to make an assignment in materials that I have identified in (b) above, I hereby warrant that I am the author of this Proposal and that I have full power and authority to enter into this assignment.

Signature (Required) \_\_\_\_\_

## PLEASE USE SEPARATE FORM FOR EACH PROPOSAL

Mail to: Secretary, Standards Council · National Fire Protection Association  
1 Batterymarch Park · Quincy, MA 02169-7471 OR  
Fax to: (617) 770-3500 OR Email to: [proposals\\_comments@nfpa.org](mailto:proposals_comments@nfpa.org)

# NFPA Document Proposal Form

**NOTE: All Proposals must be received by 5:00 pm EST/EDST on the published Proposal Closing Date.**

For further information on the standards-making process, please contact the Codes and Standards Administration at 617-984-7249 or visit [www.nfpa.org/codes](http://www.nfpa.org/codes).

For technical assistance, please call NFPA at 1-800-344-3555.

## FOR OFFICE USE ONLY

Log #: \_\_\_\_\_

Date Rec'd: \_\_\_\_\_

Please indicate in which format you wish to receive your ROP/ROC  electronic  paper  download  
(Note: If choosing the download option, you must view the ROP/ROC from our website; no copy will be sent to you.)

Date \_\_\_\_\_ Name \_\_\_\_\_ Tel. No. \_\_\_\_\_

Company \_\_\_\_\_ Email \_\_\_\_\_

Street Address \_\_\_\_\_ City \_\_\_\_\_ State \_\_\_\_\_ Zip \_\_\_\_\_

**\*\*\*If you wish to receive a hard copy, a street address MUST be provided. Deliveries cannot be made to PO boxes.**

Please indicate organization represented (if any) \_\_\_\_\_

1. (a) NFPA Document Title \_\_\_\_\_ NFPA No. & Year \_\_\_\_\_

(b) Section/Paragraph \_\_\_\_\_

2. Proposal Recommends (check one):  new text  revised text  deleted text

3. Proposal (include proposed new or revised wording, or identification of wording to be deleted): [Note: Proposed text should be in legislative format; i.e., use underscore to denote wording to be inserted (inserted wording) and strike-through to denote wording to be deleted (~~deleted wording~~).]

4. Statement of Problem and Substantiation for Proposal: (Note: State the problem that would be resolved by your recommendation; give the specific reason for your Proposal, including copies of tests, research papers, fire experience, etc. If more than 200 words, it may be abstracted for publication.)

## 5. Copyright Assignment

(a)  I am the author of the text or other material (such as illustrations, graphs) proposed in the Proposal.

(b)  Some or all of the text or other material proposed in this Proposal was not authored by me. Its source is as follows: (please identify which material and provide complete information on its source)

I hereby grant and assign to the NFPA all and full rights in copyright in this Proposal and understand that I acquire no rights in any publication of NFPA in which this Proposal in this or another similar or analogous form is used. Except to the extent that I do not have authority to make an assignment in materials that I have identified in (b) above, I hereby warrant that I am the author of this Proposal and that I have full power and authority to enter into this assignment.

Signature (Required) \_\_\_\_\_

**PLEASE USE SEPARATE FORM FOR EACH PROPOSAL**

Mail to: Secretary, Standards Council · National Fire Protection Association  
1 Batterymarch Park · Quincy, MA 02169-7471 OR  
Fax to: (617) 770-3500 OR Email to: [proposals\\_comments@nfpa.org](mailto:proposals_comments@nfpa.org)